

**BRINKLEY**

— RV —



OWNER'S MANUAL

## DEAR BRINKLEY RV CUSTOMER,

Thank you for choosing Brinkley! Your satisfaction with your Brinkley RV and the entirety of your Customer Experience is of the utmost importance to us. We are here to help you along your RVing journey to ensure that your Brinkley RV facilitates the memories that you cherish for a lifetime. Your Brinkley RV is designed and manufactured to meet and exceed all applicable state and federal regulations, codes, and requirements—including the Recreational Vehicle Industry Association's (RVIA) codes and standards and CSA codes and standards. We are committed to the safety of you and your family, keeping you on the road, and camping!

To help you get started along your journey, we supply every Brinkley RV with an Owner's Manual, Warranty Guide, and any manuals made available by the manufacturers of the various appliances and components installed in your RV. We ask that you please read these documents thoroughly, as it is very important that you and your family know how to properly use and maintain your RV, its components, systems, and appliances to ensure a safe camping experience.

You are also provided certain warranties as a benefit of your Brinkley RV Ownership. Those warranties are all included in the separate Warranty Guide provided to you with the purchase of your Brinkley RV. In addition to the owner's manuals, you should thoroughly read through the warranties provided. The Warranty Guide explains not only the warranties provided, but it also includes: coverage validity dates, the extent of coverage, what exclusions or limitations of coverage apply, and how to seek and obtain warranty service and care. Please note that some ongoing maintenance is required to be performed at specified intervals to comply with the requirements of your warranties. **Failing to perform required maintenance could result in a partial or complete loss of warranty coverage.**

Brinkley RV and our exceptional Dealer Teams are committed to providing you with an amazing Customer Experience. If we are not exceeding your expectations, please do not hesitate to contact us. **Our contact information is located at the bottom of each page of your manuals.** We are here for you. Please share with us your feedback on how we can better serve you along your journey. We need your valuable input to evolve as a company and achieve our mission:

**To provide you with the ultimate Customer Experience that creates the memories you will cherish for a lifetime!**

Sincerely,

The Brinkley RV Team





In our relentless pursuit of product improvement and the ultimate Customer experience, changes may take place at any time to the Model G. It is our goal to strive to keep this manual as up to date as possible. As changes occur, we will provide additional product information documents in the rear pocket of the Owner's Manual. We will also maintain digital versions on our website, BrinkleyRV.com. The QR code below will take you to our site.

Should you have any questions, please do not hesitate to contact us. We are here to serve you!

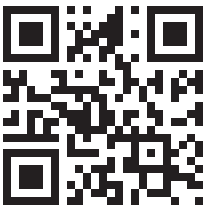

Copyright © 2023, Brinkley RV. No part of this publication may be reproduced, distributed, or transmitted in any form or by any means, including photocopying, recording, or other electronic or mechanical methods, without the prior written permission of the publisher, except as permitted by U.S. copyright law.

Version: **2023-1**

Revision Date: **5/25/2023**

# CONTENTS

## SEC.01 INTRODUCTION

|   |    |
|---|----|
| <b>A. About This Manual</b>             | 12 |
| <b>B. Owner Information Package</b>     | 13 |
| <b>C. Manufacturing Certification</b>   | 13 |
| <b>D. Vehicle Identification Number</b> | 14 |
| <b>E. Safety Precautions</b>            | 15 |
| <b>F. Additional Terminology Used</b>   | 15 |

## SEC.02 REPORTING SAFETY DEFECTS

|  |    |
|--|----|
| <b>A. How to Report Safety Defects</b> | 16 |
|--|----|

## SEC.03 SERVICE & WARRANTY

|   |    |
|---|----|
| <b>A. Dealer's Responsibilities</b>                 | 17 |
| <b>B. Owner's (Your) Responsibilities</b>           | 18 |
| <b>C. Obtaining Warranty Service</b>                | 18 |
| <b>D. Obtaining Emergency Warranty Repair</b>       | 19 |
| <b>E. Replacement Parts</b>                         | 21 |
| <b>F. Aftermarket Installations and Alterations</b> | 21 |
| <b>G. Updating Your Contact Information</b>         | 21 |

## SEC.04 OCCUPANT SAFETY

|  |    |
|--|----|
| <b>A. Develop a Family Safety Plan</b>             | 22 |
| <b>B. Emergency Weather Planning</b>               | 23 |
| 1. General Information                             | 23 |
| 2. Repairing Severe Weather Damage                 | 23 |
| <b>C. Fire Safety</b>                              | 23 |
| 1. General Information                             | 23 |
| 2. Fire Emergencies                                | 23 |
| 3. Common and Important<br>Fire Safety Information | 24 |
| 4. Fire Extinguishers                              | 25 |
| a. General Information                             | 25 |
| b. Operation                                       | 25 |
| c. Disposal  | 25 |
| <b>D. Emergency Egress Window(s)</b>               | 26 |
| 1. General Information                             | 26 |
| 2. Maintenance                                     | 26 |
| <b>E. Smoke Alarm</b>                              | 26 |
| 1. General Information                             | 26 |

|   |    |
|---|----|
| 2. Testing a Smoke Alarm                          | 27 |
| 3. Maintenance                                    | 28 |
| <b>F. Carbon Monoxide (CO)</b>                    | 28 |
| 1. General Information                            | 28 |
| 2. Carbon Monoxide (CO) Alarm                     | 29 |
| a. General Information                            | 29 |
| b. Testing the CO Alarm                           | 30 |
| c. CO Alarm Maintenance                           | 30 |
| <b>G. Propane Gas (LP) Alarm</b>                  | 31 |
| 1. General Information                            | 31 |
| <b>H. Indoor Air Quality</b>                      | 32 |
| 1. Maintaining Indoor Air Quality                 | 32 |
| 2. Improving Indoor Air Quality                   | 32 |
| 3. EPA Recommendations                            | 33 |
| 4. Chemical Sensitivity and Outgassing            | 33 |
| a. General Information                            | 33 |
| b. Formaldehyde                                   | 34 |
| c. California Air Resource Board<br>(CARB) Notice | 34 |
| 5. Condensation and Moisture                      | 34 |
| a. General  | 34 |
| b. Controlling Condensation                       | 34 |
| c. Hot Weather Conditions                         | 35 |
| d. Cold Weather                                   | 35 |
| 6. When There Is Moisture,<br>There May Be Mold   | 35 |
| a. General  | 35 |
| b. Mold Prevention                                | 36 |
| <b>I. Cold Weather Use</b>                        | 36 |
| <b>J. Websites of Interest</b>                    | 36 |
| <b>K. Additional Safety Precautions</b>           | 37 |
| 1. Generators                                     | 37 |
| 2. Loading and Weight Distribution                | 37 |
| 3. Passenger Safety                               | 37 |
| 4. Propane Appliances and Equipment               | 37 |
| 5. Tire Pressure                                  | 38 |
| 6. Towing   | 38 |

## SEC.05 PRE-TRAVEL INFORMATION

|                                  |    |
|----------------------------------|----|
| <b>A. General</b>                | 39 |
| <b>B. Tow Vehicle Disclaimer</b> | 39 |
| <b>C. Vehicle Labels</b>         | 39 |

|  |    |
|--|----|
| 1. Weight Ratings and Definitions              | 39 |
| 2. Weight Labels                               | 41 |
| 3. Federal Certification Label                 | 41 |
| 4. Tire and Loading Information Label          | 41 |
| 5. Cargo Carrying Capacity (CCC) Label         | 41 |
| 6. RV Length                                   | 42 |
| a. Travel Trailers                             | 42 |
| b. Fifth Wheel Trailers                        | 42 |
| c. RV Overall Length Exclusions                | 42 |
| <b>D. Cargo Capacities and Weights</b>         | 42 |
| 1. Maximum Load Rating                         | 42 |
| 2. Water and Propane (US ONLY)                 | 43 |
| 3. Loading Your RV                             | 43 |
| 4. Weighing the Tow Vehicle and RV             | 43 |
| a. In General                                  | 43 |
| b. Weighing Your Tow Vehicle and RV            | 44 |
| <b>E. Tire Safety Information</b>              | 46 |
| 1. Introduction                                | 46 |
| 2. Maximum Load Rating                         | 46 |
| 3. Maximum Inflation Pressure                  | 46 |
| 4. Recommended Tire Pressure and Load Limits   | 46 |
| 5. Understanding Tire Pressure and Load Limits | 46 |
| 6. Checking Tire Pressure                      | 47 |
| a. Frequency                                   | 47 |
| b. Maintaining Proper Tire Pressure            | 47 |
| 7. The Effect of Overloading Your RV and Tires | 48 |
| 8. Proper Tire Load Limits                     | 49 |
| 9. Tire Safety Tips                            | 49 |
| 10. Tire Labeling                              | 49 |
| 11. Tire Size and Type Designation             | 50 |
| <b>F. Tire Tread</b>                           | 51 |
| <b>G. Tire Ply Composition and Materials</b>   | 52 |
| <b>H. Spare Tire</b>                           | 52 |
| <b>I. Tire Changing Basics</b>                 | 53 |
| <b>J. Wheel Nut Torque</b>                     | 54 |
| <b>K. Tire Warranty</b>                        | 55 |
| <b>L. Roadside Emergency</b>                   | 55 |

## SEC.06 TIRE PRESSURE MONITORING SYSTEM

|   |    |
|---|----|
| <b>A. Display Alerts</b>                    | 57 |
| 1. Out of Parameter Alert                   | 57 |
| 2. High Pressure Alert                      | 57 |
| 3. Low Pressure Alert                       | 57 |
| 4. High Temperature Alert                   | 57 |
| 5. Fast Leak Alert                          | 58 |
| 6. Sensor Low Battery Alert                 | 58 |
| <b>B. Common Functions</b>                  | 58 |
| 1. Normal Display Scrolling                 | 58 |
| 2. Back-Lighting and Motion Detection       | 58 |
| 3. Disconnecting and Reconnecting a Vehicle | 58 |
| 4. Trailer Selection                        | 59 |
| 5. Charging the Display                     | 59 |

## SEC.07 TOWING & LEVELING

|   |    |
|---|----|
| <b>A. Recommended Safety</b>                  | 60 |
| <b>B. RV Driving Schools and Seminars</b>     | 61 |
| <b>C. RV Braking System</b>                   | 61 |
| 1. General                                    | 61 |
| 2. Brake Controller                           | 61 |
| 3. Tow Assist and ABS                         | 61 |
| <b>D. 7-Way Harness Towing Connector Plug</b> | 62 |
| <b>E. Breakaway Switch</b>                    | 62 |
| <b>F. Fifth Wheel Pin Box</b>                 | 63 |
| 1. General Information                        | 63 |
| 2. Gooseneck Pin Box                          | 64 |
| 3. Fifth Wheel Pin Box Height                 | 64 |
| 4. Standard Pin Box Hitching                  | 65 |
| 5. Gooseneck Pin Box Hitching                 | 66 |
| <b>G. Towing the RV</b>                       | 66 |
| 1. Braking and Stopping Distance              | 66 |
| 2. Weight and Clearance Limits                | 67 |
| 3. Road Conditions                            | 67 |
| 4. Turning Corners                            | 67 |
| 5. Passing                                    | 67 |
| 6. Backing-Up                                 | 68 |
| 7. Parking                                    | 68 |
| <b>H. Unhitching from the Tow Vehicle</b>     | 68 |

# CONTENTS

## SEC.08 LEVEL-UP HYDRAULIC LEVELING

|  |    |
|--|----|
| <b>A. Introduction</b>                       | 70 |
| <b>B. Components</b>                         | 70 |
| <b>C. Additional Informational Resources</b> | 70 |
| <b>D. Safety</b>                             | 70 |
| <b>E. Prior to Operation</b>                 | 71 |
| <b>F. Basic Jack Operation</b>               | 72 |
| 1. Landing Gear Jacks Operation              | 72 |
| 2. Level-Up Jacks Operation                  | 72 |
| <b>G. Troubleshooting</b>                    | 74 |
| <b>H. Zero Point Calibration</b>             | 76 |
| <b>I. Maintenance</b>                        | 76 |

## SEC.09 SLIDE-OUT SYSTEMS

|   |    |
|---|----|
| <b>A. General Information</b>                             | 80 |
| <b>B. Operation</b>                                       | 80 |
| <b>C. Slide-Out Maintenance</b>                           | 81 |
| <b>D. Lippert Through Frame Electric Slide-Out System</b> | 82 |
| 1. Manual Operation                                       | 82 |
| 2. Maintenance  | 83 |
| 3. Service and Adjustments                                | 83 |
| <b>E. Lippert In-Wall Slide-Out Systems—SlimRack®</b>     | 84 |
| 1. General Information, Extending, and Retracting         | 84 |
| 2. Troubleshooting  | 85 |

## SEC.10 HAPPIJAC POWER BED LIFT SYSTEM

|  |    |
|--|----|
| <b>A. Introduction</b>                 | 86 |
| <b>B. Safety Precautions</b>           | 86 |
| <b>C. Operation</b>                    | 86 |
| 1. General Operation                   | 86 |
| 2. Stowing/Locking the Upper Bunk      | 86 |
| 3. Un-Stowing/Releasing the Upper Bunk | 88 |
| <b>D. HappiJac Sofa Configurations</b> | 89 |
| 1. Bunk Mode                           | 89 |
| 2. Sofa Mode                           | 89 |
| 3. Flush Wall Storage Mode             | 89 |

## SEC.11 ELECTRICAL SYSTEMS

|   |     |
|---|-----|
| <b>A. General Information</b>               | 90  |
| <b>B. Electrical System Maintenance</b>     | 90  |
| <b>C. 50-Amp Power Cord</b>                 | 90  |
| 1. Shore Cord Power                         | 91  |
| 2. Power Cord Maintenance                   | 91  |
| <b>D. 120-Volt AC System</b>                | 92  |
| 1. General Information                      | 92  |
| 2. 120-Volt Circuit Breakers                | 92  |
| 3. Maintenance and Replacement              | 93  |
| 4. Converter                                | 93  |
| 5. Inspection and Maintenance               | 93  |
| 6. GFCI Receptacle                          | 93  |
| <b>E. 12-Volt DC System</b>                 | 94  |
| 1. 12-Volt DC USB Ports                     | 94  |
| 2. 12-Volt Fuse Pane                        | 94  |
| 3. Auxiliary Battery(ies)                   | 95  |
| 4. Dry Camping                              | 95  |
| 5. Maintenance/Replacement of 12V Equipment | 96  |
| <b>F. Battery Disconnect Switches</b>       | 97  |
| <b>G. Calculating Electrical Load</b>       | 97  |
| 1. General Information                      | 97  |
| 2. Approximate Electrical Load Ratings      | 98  |
| <b>H. Replacing Light Bulbs</b>             | 98  |
| <b>I. Solar Power</b>                       | 98  |
| 1. Solar Docking Port                       | 99  |
| 2. Solar Power Charging System              | 99  |
| 3. Inverter                                 | 99  |
| 4. Battery Monitor                          | 100 |

## SEC.12 GENERATOR

|                                   |     |
|-----------------------------------|-----|
| <b>A. Introduction</b>            | 102 |
| 1. Safety Precautions             | 102 |
| 2. Before Operating the Generator | 102 |
| 3. Generator Control Panel Basics | 103 |
| 4. VFT Display                    | 104 |
| 5. Remote Operation Panel         | 104 |
| <b>B. Generator Operation</b>     | 104 |
| 1. Breaking-In the New Engine     | 104 |
| 2. Pre-Start Checks               | 104 |
| 3. Before Each Start              | 104 |

|                                      |     |
|--------------------------------------|-----|
| 4. Starting the Generator            | 105 |
| 5. Resetting Overload                | 106 |
| 6. Stopping the Generator            | 106 |
| 7. Connecting to Utility Power       | 106 |
| 8. Loading the Generator             | 106 |
| 9. Altitude Adjustment               | 107 |
| 10. Operating in Cold Weather        | 108 |
| 11. Operating in Hot Weather         | 108 |
| 12. Hot Weather Operating Tips       | 108 |
| 13. Hot Ambient Air                  | 109 |
| 14. Ventilation                      | 109 |
| 15. Safe Temperature Operating Range | 109 |
| 16. Operating in a Dusty Environment | 110 |
| <b>C. General Inspections</b>        | 110 |
| 1. Exhaust System                    | 110 |
| 2. Fuel System                       | 110 |
| 3. Battery System                    | 110 |
| 4. Mechanical System                 | 111 |
| 5. Checking Engine Oil Level         | 111 |
| <b>D. Troubleshooting</b>            | 112 |

## SEC.13 FUEL STATION

|                                  |     |
|----------------------------------|-----|
| <b>A. Introduction</b>           | 112 |
| <b>B. General Safety</b>         | 112 |
| <b>C. Filling the Fuel Tanks</b> | 113 |
| <b>D. Dispensing Fuel</b>        | 113 |

## SEC.14 AUDIO & VIDEO

|  |     |
|--|-----|
| <b>A. Introduction—Audio &amp; Video</b>         | 116 |
| <b>B. Audio—Rockford Fosgate® Sound System</b>   | 116 |
| 1. Features of the Wired Remote—<br>Punch PMX-1R | 116 |
| 2. Locations of the Punch PMX-iR Remote          | 116 |
| 3. PMX-iR Remote—Features                        | 117 |
| 4. Basic Operation of the System                 | 120 |
| 5. Tuner Operation                               | 120 |
| <b>C. Audio/Video Systems—Televisions</b>        | 125 |
| 1. TV Operation—Main Living Area                 | 125 |
| 2. TV Receptions Basics                          | 126 |
| 3. TV Signal Booster                             | 126 |
| 4. Cable/Satellite Outlet                        | 126 |

|                           |     |
|---------------------------|-----|
| 5. TV Roof Antenna        | 127 |
| 6. Vision S Camera System | 128 |

## SEC.15 CONNECTIVITY

|   |     |
|---|-----|
| <b>A. General Information</b>                                   | 128 |
| <b>B. Connecting to Travlfi</b>                                 | 128 |
| <b>C. Wi-Fi Extender Mode with Travlfi</b>                      | 129 |
| <b>D. Winegard Gateway Wi-Fi Router<br/>(Customer Supplied)</b> | 131 |

## SEC.16 ONECONTROL

|   |     |
|---|-----|
| <b>A. Using Your RV's OneControl System</b> | 132 |
| <b>B. Device Access</b>                     | 132 |
| <b>C. OneControl Touch Panel</b>            | 132 |
| 1. Device Library                           | 132 |
| 2. First Usage                              | 132 |
| 3. Device Types                             | 133 |
| 4. Battery Voltage                          | 133 |
| 5. Device Families                          | 133 |
| 6. All Motion                               | 133 |
| 7. Wind Sensors                             | 133 |
| 8. Wind Sensor Operation                    | 134 |
| 9. All Lighting                             | 134 |
| 10. HVAC Zones                              | 135 |
| 11. Modes                                   | 135 |
| 12. Fan                                     | 136 |
| 13. Resources                               | 136 |
| 14. Favorites                               | 136 |
| <b>D. Device Details</b>                    | 137 |
| 1. Generator                                | 137 |
| 2. Leveling                                 | 137 |
| 3. Accessories                              | 137 |
| 4. Camp Manager                             | 137 |
| <b>E. Monitor Panel</b>                     | 138 |
| <b>F. OneControl Mobile App</b>             | 138 |
| 1. App Pairing                              | 139 |
| 2. App Access                               | 139 |
| 3. App Functions                            | 139 |
| 4. Home Page                                | 139 |
| 5. Modes                                    | 140 |
| 6. Favorites                                | 141 |

# CONTENTS

|  |     |                                   |     |
|--|-----|-----------------------------------|-----|
| 7. All Lights  | 141 | 3. Manually Overriding the Awning | 160 |
| 8. RV Health Monitor                                       | 141 | 4. Maintenance of the Awning      | 161 |
| 9. Checklists  | 142 |                                   |     |
| 10. Auto Set-Up  | 142 |                                   |     |
| 11. Device Library   | 146 |                                   |     |
| 12. Wind Sensors   | 147 |                                   |     |
| 13. Lights   | 148 |                                   |     |
| 14. Generator  | 148 |                                   |     |
| 15. Leveling   | 148 |                                   |     |
| 16. Bed Lifts  | 148 |                                   |     |
| <b>G. Customization</b>                                    | 149 |                                   |     |
| 1. Liquid Propane Sensors                                  | 149 |                                   |     |
| 2. Temperature Sensors                                     | 149 |                                   |     |
| 3. Keyless Bluetooth Door Locks                            | 149 |                                   |     |
| <b>H. Resources</b>  | 149 |                                   |     |
| <b>SEC.17 HEATING &amp; COOLING (HVAC)</b>                 |     |                                   |     |
| <b>A. Introduction</b>                                     | 150 |                                   |     |
| <b>B. Air Conditioner With Heat Pump</b>                   | 150 |                                   |     |
| 1. Ducted A/C  | 150 |                                   |     |
| 2. Duct Work and Return Air                                | 150 |                                   |     |
| 3. Heat Pump   | 150 |                                   |     |
| 4. Cooling vs Heat Gain                                    | 151 |                                   |     |
| 5. Air Conditioner Gasket                                  | 151 |                                   |     |
| <b>C. Furnace</b>  | 151 |                                   |     |
| <b>D. Fireplace</b>  | 152 |                                   |     |
| <b>E. Roof Vents</b>                                       | 153 |                                   |     |
| <b>SEC.18 AWNINGS</b>                                      |     |                                   |     |
| <b>A. Main Awnings—Solera</b>                              | 154 |                                   |     |
| 1. Awning Extension  | 154 |                                   |     |
| 2. Retracting the Awning                                   | 155 |                                   |     |
| 3. Pitch Adjustment—Solera Awnings                         | 155 |                                   |     |
| 4. Maintenance—Solera                                      | 156 |                                   |     |
| 5. Troubleshooting/Manual Override                         | 157 |                                   |     |
| <b>B. Slide Topper Awnings—Dometic</b>                     | 157 |                                   |     |
| 1. Operation   | 158 |                                   |     |
| 2. Maintenance   | 158 |                                   |     |
| <b>C. Rear Patio Awning—Thule</b>                          | 159 |                                   |     |
| 1. General Safety  | 160 |                                   |     |
| 2. Operating the Awning                                    | 160 |                                   |     |
| <b>SEC.19 APPLIANCES</b>                                   |     |                                   |     |
| <b>A. General Information</b>                              | 166 |                                   |     |
| <b>B. Microwave</b>  | 166 |                                   |     |
| <b>C. 12-Volt Refrigerator</b>                             | 166 |                                   |     |
| <b>D. Cooking with Propane</b>                             | 167 |                                   |     |
| <b>E. Outdoor Cooktop (If Equipped)</b>                    | 168 |                                   |     |
| <b>F. Oven</b>   | 168 |                                   |     |
| <b>G. Range Hood (If Equipped)</b>                         | 168 |                                   |     |
| <b>H. Range Top with Oven</b>                              | 169 |                                   |     |
| <b>I. Washer/Dryer Prep</b>                                | 169 |                                   |     |
| 1. Master Bedroom Prep                                     | 169 |                                   |     |
| 2. Garage Prep   | 170 |                                   |     |
| <b>SEC.20 PROPANE (LP) SYSTEMS</b>                         |     |                                   |     |
| <b>A. General Information</b>                              | 171 |                                   |     |
| <b>B. Maintenance</b>                                      | 171 |                                   |     |
| <b>C. Propane Gas</b>                                      | 171 |                                   |     |
| <b>D. Propane Gas Cylinders</b>                            | 172 |                                   |     |
| 1. General Information                                     | 172 |                                   |     |
| 2. Servicing or Filling                                    | 173 |                                   |     |
| 3. LP Gas Container Overfill                               | 173 |                                   |     |
| 4. Propane Leak Test                                       | 173 |                                   |     |
| 5. Propane Gas Alarm                                       | 174 |                                   |     |
| 6. Installing the Propane Cylinders                        | 174 |                                   |     |
| <b>E. Propane Regulator</b>                                | 175 |                                   |     |
| <b>F. Propane System Hoses, Tubes, Pipes, and Fittings</b> | 176 |                                   |     |
| <b>G. Cooking with Propane</b>                             | 176 |                                   |     |
| <b>H. Traveling with Propane</b>                           | 176 |                                   |     |
| <b>I. Operating the Propane System</b>                     | 177 |                                   |     |
| <b>J. Calculating Propane Use</b>                          | 177 |                                   |     |
| <b>SEC.21 PLUMBING SYSTEMS</b>                             |     |                                   |     |
| <b>A. Introduction</b>                                     | 178 |                                   |     |
| <b>B. First Use of the Fresh Water System</b>              | 178 |                                   |     |
| <b>C. Tank Monitoring</b>                                  | 178 |                                   |     |

|   |     |   |     |
|---|-----|---|-----|
| <b>D. Water Pressure Regulator<br/>(Customer Supplied)</b>                  | 180 | 2. Preventing Toilet Blockage   | 202 |
| <b>E. Water Pump Switch</b>   | 180 | 3. Cleaning and Maintenance   | 202 |
| <b>F. 12-Volt Water Pump</b>  | 180 | <b>T. Black and Gray Water Holding Tanks</b>  | 202 |
| <b>G. Water Filtration System</b>   | 180 | 1. Black Water Tank Preparation   | 202 |
| <b>H. Fresh Water Holding Tank</b>  | 181 | 2. Gray Water Tank Preparation  | 203 |
| <b>I. Water Heater—Tankless</b>   | 182 | 3. Emptying Black and Gray Water Tanks  | 203 |
| 1. General  | 182 | 4. Gray and Black Tank Valve Switches, Sewer<br>Outlet, and Sewer Hose Storage Tube | 203 |
| 2. Controller Operation   | 182 | 5. Manually overriding the Gray<br>and Black Power Tank Valves                      | 204 |
| 3. Safe Operation   | 183 | 6. Dump Station Locations   | 205 |
| 4. Water Control  | 183 | 7. Vents and Vent Pipes   | 205 |
| 5. High Altitude Use  | 183 | 8. Drainpipes With Dry Sealing Valve  | 205 |
| 6. Storage and Transit  | 184 | 9. Black Tank Flusher   | 206 |
| 7. Operating in Freezing Temperatures                                       | 184 |   |     |
| 8. Routine Inspection   | 184 |   |     |
| 9. Hard Water Treatment   | 185 |   |     |
| <b>J. Bathroom Shower</b>   | 186 |   |     |
| 1. General  | 186 |   |     |
| 2. Maintenance  | 186 |   |     |
| 3. Shower Door  | 186 |   |     |
| <b>K. Faucets</b>   | 187 |   |     |
| <b>L. Exterior Spray Ports</b>  | 187 |   |     |
| <b>M. Universal Docking Convenience Center—<br/>The Nautilus P4-3 Panel</b> | 188 |   |     |
| 1. General  | 188 |   |     |
| 2. Handle Position & Valve Routing Info                                     | 189 |   |     |
| 3. Fresh Water Tank PowerFILL   | 189 |   |     |
| 4. Sanitizing the Fresh Water<br>Tank—“Sanitize”                            | 189 |   |     |
| 5. Fresh Tank Supply—“Dry Camping”  | 190 |   |     |
| 6. Utilizing a Pressurized Water<br>Source—“City Water”                     | 192 |   |     |
| 7. Rinsing the Waste Tank—“Tank Flush”                                      | 192 |   |     |
| 8. Integrated Fresh Water Retractable<br>Hose Reel                          | 194 |   |     |
| <b>N. Draining the Fresh Water System</b>                                   | 194 |   |     |
| <b>O. Sanitizing the Fresh Water System</b>                                 | 195 |   |     |
| <b>P. Winterizing the Plumbing System</b>                                   | 196 |   |     |
| <b>Q. De-Winterizing the Plumbing System</b>                                | 199 |   |     |
| <b>R. Black Water and Gray Water Systems</b>                                | 201 |   |     |
| <b>S. Toilet</b>  | 202 |   |     |
| 1. General  | 202 |   |     |

## SEC.22 FURNITURE

|                                       |     |
|---------------------------------------|-----|
| <b>A. Entertainment Recliner Sofa</b> | 207 |
| <b>B. Entertainment Stands</b>        | 207 |
| <b>C. Dinette Table (If Equipped)</b> | 208 |
| <b>D. Bedroom Dresser</b>             | 208 |
| <b>E. HappiJac Sofa</b>               | 209 |

## SEC.23 ENTRY DOOR & STEP SYSTEM

|                                |     |
|--------------------------------|-----|
| <b>A. Main Entry Door</b>      | 210 |
| 1. Integrated Window Shade     | 210 |
| 2. Lippert Screen Shot         | 210 |
| 3. Lippert Screen Assist       | 210 |
| 4. Lippert Screen Defender     | 210 |
| 5. Keyless Entry               | 210 |
| 6. Telescoping Handrail        | 211 |
| 7. Main Entry Door Step System | 212 |
| <b>B. Garage Door</b>          | 214 |
| 1. Lippert Screen Shot         | 214 |
| 2. Lippert Screen Assist       | 214 |
| 3. Lippert Screen Defender     | 214 |
| 4. Keyed Lock                  | 214 |
| 5. Handrail                    | 215 |
| 6. Garage Entry Door Steps     | 215 |
| <b>C. 3-Seasons Door</b>       | 216 |
| 1. Interior Lock               | 216 |



# CONTENTS

|   |     |
|---|-----|
| 2. Exterior Handles                       | 216 |
| 3. LED Lighting                           | 216 |
| 4. Screens                                | 216 |
| 5. Sliding Panels                         | 217 |
| 6. Pivot Panels                           | 217 |
| 7. Removable Panels                       | 218 |
| 8. Storm Windows                          | 219 |
| <b>D. Compartment and Entry Door Keys</b> | 219 |

## SEC.24 RAMP DOOR & PATIO

|                                 |     |
|---------------------------------|-----|
| <b>A. Ramp Door Operation</b>   | 220 |
| 1. Exterior Operation           | 220 |
| 2. Interior Ramp Door Operation | 221 |
| 3. Patio Position               | 222 |
| 4. Ramp Position                | 223 |
| <b>B. Patio Kit</b>             | 224 |

## SEC.25 ACCESSORIES

|  |     |
|--|-----|
| <b>A. Interior Accessories</b>                       | 230 |
| 1. Pantry  | 230 |
| 2. Spice Rack  | 230 |
| 3. Silverware Drawer                                 | 231 |
| 4. Knife Drawer                                      | 231 |
| 5. Island Extension                                  | 232 |
| 6. Cutting Board                                     | 232 |
| 7. Pet Food Bowls—Integrated into the Kitchen Island | 233 |
| 8. Bathroom Storage                                  | 233 |
| 9. Garage Hidden Storage                             | 233 |
| 10. Recessed L-Track                                 | 234 |
| <b>B. Exterior Accessories</b>                       | 234 |
| 1. Mini Refrigerator                                 | 234 |
| 2. MORryde Cargo Tray                                | 234 |
| 3. Shore Cord Reel                                   | 234 |
| 4. Air Compressor                                    | 235 |
| 5. Air Hose Reel                                     | 235 |
| 6. Power Cord Reel                                   | 235 |

## SEC.26 RV EXTERIOR CARE

|  |     |
|--|-----|
| <b>A. General</b>                        | 236 |
| <b>B. Exterior Cleaning</b>              | 236 |
| <b>C. Washing</b>                        | 236 |
| <b>D. During Cold Weather</b>            | 237 |
| <b>E. RV Waxing</b>                      | 237 |
| <b>F. RV Polishing</b>                   | 237 |
| <b>G. Damaged Paint</b>                  | 237 |
| <b>H. Plastic Components</b>             | 238 |
| <b>I. Chrome Parts (If Equipped)</b>     | 238 |
| <b>J. Exterior Roof</b>                  | 238 |
| <b>K. Sidewall Vents</b>                 | 238 |
| <b>L. Sealants</b>                       | 238 |
| <b>M. Roof Ladder</b>                    | 239 |
| <b>N. RV Frame/Chassis</b>               | 239 |
| <b>O. Windows</b>                        | 239 |
| <b>P. Ramp Doors and Patio Rail Kits</b> | 240 |
| <b>Q. RV Storage Preparation</b>         | 240 |
| <b>R. Snow Removal</b>                   | 241 |

## SEC.27 RV INTERIOR CARE

|   |     |
|---|-----|
| <b>A. Cleaning the Interior</b>                             | 242 |
| <b>B. Tables, Cabinets, and Drawers</b>                     | 242 |
| <b>C. Wall, Ceiling, and Cabinet Paneling</b>               | 242 |
| <b>D. Countertops</b>                                       | 242 |
| <b>E. Vinyl Flooring</b>                                    | 242 |
| <b>F. Dinette Table, Dinette Chairs</b>                     | 244 |
| 1. Potable Dinette Table                                    | 244 |
| 2. Bar Stools   | 244 |
| <b>G. Furniture Upholstery</b>                              | 244 |
| 1. Fabric   | 244 |
| 2. Vinyl  | 244 |
| 3. ABS Plastic  | 245 |
| <b>I. Décor</b>   | 245 |
| 1. Glass Décor  | 245 |
| 2. Window Treatments  | 245 |
| 3. Blinds and Shades  | 245 |
| <b>J. Shower Walls</b>                                      | 245 |
| <b>K. Sink and Shower Fixtures</b>                          | 245 |
| <b>L. Stainless Steel Sink and Appliances (If Equipped)</b> | 245 |



**SEC.28 MAINTENANCE**

|  |     |
|--|-----|
| <b>A. Maintenance Checklist</b>        | 246 |
| 1. Prior to Your First Trip in Your RV | 246 |
| 2. Each Trip                           | 246 |

**SEC.29 BASIC TROUBLESHOOTING**

|   |     |
|---|-----|
| <b>A. Air Conditioner (Roof)</b>  | 248 |
| 1. A/C Will Not Operate   | 248 |
| 2. A/C Operates, but Coil Freezes and Compressor Cycles Prematurely   | 248 |
| 3. A/C Does Not Effectively Get Cold  | 248 |
| <b>B. Electrical Power</b>  | 248 |
| 1. No 12-Volt Power   | 248 |
| 2. No 12-Volt Power While Utilizing Shore Power   | 249 |
| 3. No 12-Volt Power While Utilizing Inverter Power  | 249 |
| 4. No 12-Volt Power While Utilizing Generator   | 249 |
| <b>C. Furnace</b>   | 249 |
| 1. Furnace Does Not Ignite and/or Cycles Frequently   | 249 |
| <b>D. Interior Lights</b>   | 250 |
| 1. If Lights Flicker  | 250 |
| 2. Lights Dim or are Half Bright  | 250 |
| <b>E. Microwave</b>   | 250 |
| 1. Will Not Operate   | 250 |
| <b>F. Monitor Panel</b>   | 250 |
| 1. No Lights at Control Panel When Switch is Pressed  | 250 |
| 2. Holding Tank Lights Deliver False Readings   | 250 |
| <b>G. Outside Receptacle</b>  | 250 |
| 1. No Power to Exterior Receptacle  | 250 |
| <b>H. Oven</b>  | 250 |
| 1. Oven Slow to Warm, Poor Baking, Poor Ignition of Burners, Pilots Won't Stay Lit, Top Burners Popping Sound, Carbon on Pilot Shield or Burner Flame Too Low or Too High | 250 |
| 2. Top Burner or Oven Burner Won't Light or Won't Stay Lit  | 251 |
| 3. Gas Smell  | 251 |

|  |     |
|--|-----|
| <b>I. Generator</b>  | 251 |
| 1. Starter Engages When Holding Start Button, but Generator Does Not Start | 251 |
| 2. If Generator Start Button is Pushed, and Nothing Happens                | 251 |
| 3. Generator Starts, but Lacks Sufficient Power Supply                     | 251 |
| 4. Generator Makes Clicking Sound When Attempting to Start                 | 251 |
| <b>J. Propane Gas</b>  | 251 |
| 1. Smell of Gas in or Around Unit  | 251 |
| <b>K. Refrigerator</b>   | 252 |
| 1. Control Panel Lights Are Not Illuminating                               | 252 |
| 2. Lights Are Illuminating, But Not Properly Cooling                       | 252 |
| 3. Frost Buildup on Evaporator Fins  | 252 |
| <b>L. Running Lights</b>   | 252 |
| 1. Running Lights Not Operating  | 252 |
| <b>M. Slide-Out</b>  | 252 |
| 1. Runs In and Out Slowly Binds, and/or Squeaks                            | 252 |
| 2. Water Entering at the Rear Corners                                      | 252 |
| 3. Room Will Not Move In or Out  | 252 |
| <b>N. Termination Valve</b>  | 253 |
| 1. Leak in Termination Valve   | 253 |
| <b>O. TV Antenna</b>   | 253 |
| 1. Poor TV Reception   | 253 |
| <b>P. Waste Tank</b>   | 253 |
| 1. Waste Tank (Black) Will Not Properly Drain                              | 253 |
| <b>Q. Water Heater—Tankless</b>  | 253 |
| <b>R. Water Pump</b>   | 253 |
| 1. Pump Inoperable   | 253 |
| 2. Pump Will Not Prime   | 253 |
| 3. Pump Runs Even When Water is Off  | 253 |
| <b>S. Water System</b>   | 253 |

**SEC.30 GLOSSARY**

|          |     |
|----------|-----|
| Glossary | 254 |
|----------|-----|

**SEC.31 MAINTENANCE RECORD**

|                    |     |
|--------------------|-----|
| Maintenance Record | 262 |
|--------------------|-----|

# SEC.01 INTRODUCTION

## A. ABOUT THIS MANUAL

The Brinkley RV Owner's Manual is intended to safely guide you through the proper use and maintenance of your Brinkley RV along with its unique components and features. Understanding the operational procedures of your Brinkley RV will allow you to better understand how to use your RV and, in turn, maximize your RV experience.

Please know, this manual is not intended to be inclusive of every and all operational aspects of your RV. The separate component and appliance owner's manuals should also be thoroughly reviewed. Because there are various options that may be selected within the build of each RV, each Brinkley RV may contain options, features, and/or components that are not included on your RV.

We wish that we could provide you with all the information required to ensure your safety during towing, transportation, and camping. The campsites you choose, your tow vehicle, and the road conditions you encounter along your journey are too numerous for us to cover all the potential scenarios.

**You are ultimately responsible for the safe use, operation, and transportation of your RV.**

If you have questions related to safety, please contact us. We will gladly provide you with additional guidance related to your specific camping and transportation scenarios.

Additionally, due to our dedication to continuous product improvements and updates, some photographs, components, systems, and diagrams may be different from what is supplied within this manual. If we can make our products better, we will strive to make those improvements as quickly as humanly possible.

**At the time of publication, this information is accurate, but is subject to change at any time without notice. You can access the most up to date version of the Owner's Manual by visiting our website, [www.BrinkleyRV.com](http://www.BrinkleyRV.com) or by scanning the QR code located on the back cover of this Owner's Manual.**

If you happen to have any additional questions or concerns, or simply need assistance of any kind, please do not hesitate to reach out to your Brinkley RV Dealer or the Brinkley RV Customer Care Team. Below, you will find our contact information. Our contact information is also located at the bottom of each page of this manual. Remember, we are just one phone call away.

### CONTACT INFORMATION:

**Email:** [CustomerCare@BrinkleyRV.com](mailto:CustomerCare@BrinkleyRV.com)

**Phone:** (574) 501-4280 or toll free  
(888) 502-3460

**Address:** Brinkley RV  
Attn: Customer Care  
1655 Brinkley Way East  
Goshen, IN 46528

## B. OWNER INFORMATION PACKAGE

Within your RV, you will find an Owner's Information Package that contains the Owner's Manual, Warranty Guide, Component Manuals, and Warranty Registrations for the appliances and components within your new Brinkley RV.

- **Before Using Your RV**, it is vital you read all documents within the Owner's Information Package. Your safety is important to us, and we want you to have the best possible experience with your Brinkley RV.

### + NOTICE

Some component manuals will not be provided within your Owner's Information Package and can only be found online via the component supplier website.

- **Register and activate your component warranties** within the required time frame to avoid loss of warranty coverage. Please note that there are some component manufacturers who provide additional warranties beyond that of the Brinkley RV Limited Base and Structural Warranties. Please See [Section 4](#) in the separate Warranty Guide for additional details.

### + NOTICE

It is highly recommended that you have your selling Dealer register your warranties. It is their obligation to register your warranties on your behalf at the time of sale. Failing to register your warranties may prevent you from utilizing the benefits of SafeRide prior to registration. See [Section 3\(D\)2](#). Additionally, registering at the time of sale ensures that you are afforded the full benefit of all warranties.

## C. MANUFACTURING CERTIFICATION

All Brinkley RVs are required to meet and/or exceed the safety and manufacturing codes, regulations, and standards of the Recreational Vehicle Industry Association (RVIA).

- RVIA and Transport Canada both conduct random product audits on a frequent basis to ensure that all Brinkley RV's are manufactured to U.S. (RVIA) and Canadian (CSA) standards.



- Depending on where the RV is being transported and sold, an RVIA and/or CSA Group label can be found on the sidewall next to the main entry door. This label confirms that your RV has been manufactured to the required codes and standards of RVIA and/or CSA.

### + NOTICE

The RVIA and CSA Codes and standards are not identical and can vary from each other depending on their requirements.

**Content within the Brinkley RV Owner's Information Package including the Owner's Manual, Warranty Guide, Component Manuals, etc. should be considered a permanent component of the RV. In the event this RV is traded or sold, all documents should remain within the RV for the next owner.**

# SEC.01 INTRODUCTION

## D. VEHICLE IDENTIFICATION NUMBER

Each Brinkley RV is assigned a 17-digit vehicle identification number also referred to as the “VIN.” This identification number is located on the VIN tag which can be found on the A-frame of a travel trailer or the hitch (also known as the pin box) on fifth wheels. As a secondary location, the VIN can also be found on the Federal Certification Label See [Section 5C\(3\)](#).

Please see the typical de-coding of a Brinkley RV VIN below:

### + NOTICE

The last seven (7) digits of the VIN are also known as the RV serial number. For example, using the supplied VIN below, the serial number would be 2000001.



**SAE WORLD IDENTIFIER:**  
7T0 – BRINKLEY RV

**CLASS:**  
F = FIFTH WHEEL  
T = TRAVEL TRAILER

**BRAND:**  
Z – MODEL Z  
G – MODEL G

**LENGTH:**  
THIS NUMBER IS A GROUPING NUMBER  
PREDETERMINED BASED ON THE  
SPECIFIED GROUP THE RV LENGTH  
FALLS WITHIN RATHER THAN THE  
ACTUAL LENGTH OF THE RV.

**MODEL YEAR:**  
N – 2022  
P – 2023  
R – 2024  
S – 2025

## E. SAFETY PRECAUTIONS

There are many safety precautions you should be aware of and take while enjoying your RV. These include but are not limited to:

- **Safety during the transportation of our RV.**
- **Functional safety while utilizing all RV components and features.**
- **Environmental safety while visiting different locations.**
- **Occupant safety while staying in the RV over the course of your trip.**

Safety is, and should be, exercised in every aspect of your RV experience. The personal safety of you, your family, and those around you are of the greatest importance to us at Brinkley RV.

Many appliances and related equipment within the RV (stove, outdoor grills, generator, water heater, furnace, etc.) will operate utilizing propane and/or will exhaust carbon monoxide. While using these items or any other related potential safety hazard, it is crucial that safety remains your number one priority. Be sure to follow all instructions and warnings related to your RV referenced in this manual as well as each supplier's component manual. Below is a guide to the common safety related symbols utilized throughout this manual to ensure that you are aware of potential safety concerns:

### **DANGER**

**This indicates an imminent hazard that, if not avoided or handled correctly, will result in death or serious injury.**

### **WARNING**

**This indicates a potential hazard that, if not avoided or handled correctly, may result in death or serious injury.**

### **CAUTION**

**This indicates a potential hazard that, if not avoided or handled correctly, may result in minor or moderate injury.**

### **+ NOTICE**

This is used to address best practices that should be utilized and do not commonly result in injury but may lead to property damage if not careful. Notices are also utilized throughout the manual to call attention to important information that you should be aware of.

## F. ADDITIONAL TERMINOLOGY USED

### **Customer Supplied**

Indicates any and all aftermarket items not installed, provided, or included with the RV as built by Brinkley RV. Any item deemed "Customer Supplied" is not covered under the Brinkley Limited Base Warranty or Limited Structural Warranty.

### **If Equipped**

Indicates any and all items that may be included and/or installed by Brinkley on a particular RV. All items referred to with the phrase "If Equipped," must be installed during the manufacturing process and cannot be installed or added at a later date. The phrase "If Equipped" does not imply or suggest such items are available, supplied, or included with any given Brinkley RV.

### **Optional**

Indicates any and all items that may be an option and/or feature added to a particular Brinkley RV. Some "Optional" items and/or features can only be installed within the manufacturing process and cannot be added as an aftermarket item. The term "Optional" does not imply or suggest such items are available, supplied, or included with any given Brinkley RV.

## SEC.02 REPORTING SAFETY DEFECTS

### A. HOW TO REPORT SAFETY DEFECTS

To ensure safety, from time to time, a recall may be initiated to prevent a possible product failure from manifesting into something greater. A Safety Recall includes any possible malfunction that may lead to personal injury and/or property damage. If a recall is deemed necessary, a notice will be mailed to your address on file and emailed, if an email address has been provided by you. Please be sure that you supply Brinkley RV with an accurate home address and email address. The purpose of this process is to ensure you are notified of the recall and to ensure the RV is taken to a Brinkley Authorized Dealer or Service Center for correction prior to continuing use. For instructions on how to update your contact information, please see [Section 3G](#) of this manual.

#### + NOTICE

It is very important to keep your contact information updated. It is also vital for the unit to be taken to an Authorized Dealer or Service Center to remedy the concern prior to using the RV or related component again.

If you believe your vehicle may contain a defect that can lead to injury, accident, property damage, or death, both Brinkley RV and the National Highway Traffic Safety Administration (NHTSA), should be notified immediately.

In the circumstance NHTSA receives multiple complaints on an issue, an investigation will be opened for review. This is to assist in the determination process required to locate the safety concern and to launch a recall and a remedy campaign (if needed). If NHTSA finds that a safety defect exists in any group of RV's, it may order a recall and require a remedy campaign. Once a recall is established, NHTSA cannot become involved with any action or circumstance between you, the Dealer, and/or Brinkley RV.

All communications related to the recall must be handled by Brinkley RV, your Dealer, and you as the owner of the RV.

A Service Campaign may also be launched for a potential product failure. Unlike a recall, a Service Campaign is less severe in that the product failure is not likely to lead to personal injury. And, unlike a recall, the correction process for a Service Campaign is not mandatory but is highly recommended.

Recalls and Service Campaigns can be found on the NHTSA website. As a reminder, this information will also be mailed to the contact information on the RV file.

#### TO CONTACT NHTSA IN THE UNITED STATES:

Please visit their website at [www.safercar.gov](http://www.safercar.gov); call their toll-free hotline at 1 (888) 327-4236 (Hearing impaired (TTY): 1 (800) 424-9153); or send your correspondence to:

NHTSA Headquarters  
Attn: Administrator  
1200 New Jersey Avenue SE  
Washington, DC 20590

#### TO CONTACT NHTSA IN CANADA: (Known as "Transport Canada")

Please visit their website at [www.tc.gc.ca](http://www.tc.gc.ca); call their toll-free hotline at 1 (800) 333-0510 (819) 994-3328 in the Gatineau-Ottawa area or internationally), or send your correspondence to:

Transport Canada-ASFAD  
330 Sparks St.  
Ottawa, ON K1A 0N5



## A. DEALER'S RESPONSIBILITIES

At the time your Brinkley RV is purchased, your Dealer is expected to:

1. **DELIVER your RV in the best condition possible.** Your RV must pass the Dealer's Pre-Delivery Inspection (PDI). This inspection tests all systems and components. No Brinkley RV should leave a Dealer's lot without first ensuring that all systems and components are in proper working order.
2. **PROVIDE an orientation to familiarize you with how to operate all systems and components of your new RV.** This orientation is extremely important to ensuring you understand how to properly use the RV prior to camping. Brinkley RV requires its Dealers to provide you with a comprehensive walk through of the RV prior to you leaving their Dealership. You should ask as many questions as possible to ensure you are prepared to safely utilize your Brinkley RV and that you are trained on the use of all the features of the RV. Please contact us directly if the orientation is not completed to your satisfaction.

### + NOTICE

THE ORIENTATION IS THE MOST IMPORTANT PART OF THE RV PURCHASE PROCESS. This is your opportunity to ask as many questions as possible. The most common frustrations generally result from a lack of understanding how to properly use the various systems of the RV as well as a basic understanding of how the batteries and electrical systems work.

3. **REVIEW with you and explain the provisions of the Limited Base Warranty and Limited Structural Warranty.** It is our goal to ensure that you understand your rights and responsibilities to gain the complete benefit of the warranties afforded to you. These warranties, as well as the additional

component and appliance warranties, are summarized in the separate Brinkley RV Warranty Guide. If you have questions, please contact us.

4. **SEND your completed Warranty Registration and New Vehicle PDI Checklist to Brinkley RV.** Your Warranty Registration Form is required to be submitted within fourteen (14) days of the RV delivery date to activate your warranty coverage. We expect every Brinkley RV Authorized Dealer to assist you with your warranty registrations and to complete this process prior to you leaving the Dealership. We expect the registrations will be completed by the Dealer on the actual date of purchase. We provide fourteen (14) days from the purchase date to ensure you are afforded adequate time to register. Please contact us immediately if your Dealer did not assist you in registering your warranties.
5. **ENSURE that you receive a complete Owner Information Package.** Your Dealer must ensure that you obtain a copy of the Brinkley RV Owner's Manual, individual component manuals, and Warranty Guide.
6. **EXPLAIN how to obtain local and out-of-town service for your RV, and its components and appliances.** It is our goal to ensure you know how to obtain service regardless of whether or not the service is covered by your warranties. If your RV has an issue, we want to ensure that it is promptly fixed. You can always contact us directly at any time for assistance.
7. **SERVICE all Brinkley RV products.** Each and every Brinkley RV Authorized Dealership is required to provide service on all Brinkley RV products. RVs are intended to permit you to travel across North America and explore all it has to offer. If you are traveling and cannot access your selling Dealership, please consult our website for both a Dealer and Mobile Service Locator or call Brinkley Customer Care for assistance.

## SEC.03 SERVICE & WARRANTY

### + NOTICE

To activate your Brinkley RV One (1) Year Limited Base Warranty and Three (3) Year Limited Structural Warranty you **MUST** complete the Warranty Registration within fourteen (14) days of purchase. In addition to the Brinkley registration, you must also complete the required component registrations. If you fail to do so, our suppliers will honor their warranties based on the Brinkley registration submitted upon purchase. All warranties start on the date of purchase and are in effect for their stated durations. Your Dealer is required to help facilitate all warranty registrations at the time of purchase. If you do not register your RV within the required timeframes, warranty may be forfeited.

### B. OWNER'S (YOUR) RESPONSIBILITIES

Routine care and maintenance of your RV is a part of owning your Brinkley RV. The conditions of the roads and highways you encounter as well as exposure to weather and the elements can all take a toll on the condition of your RV. As such, it is your responsibility to care and maintain your Brinkley RV in accordance with the Warranty Guide, component manuals, and this manual. Proper maintenance will improve the longevity of your RV and will prevent situations where warranty coverage is lost due to neglect.

In the circumstance warranty repairs and/or service is needed, it is your responsibility to transport the RV to and from your Authorized Dealer. We ask that you always first attempt to obtain the needed warranty service work through your selling Brinkley RV Dealer. However, if this is not possible for any given reason, Brinkley RV is more than willing to assist you in locating alternatives. Please do not hesitate to contact us at any time. It is also highly recommended that you obtain insurance coverage on your RV. This coverage will afford you protection for or against personal liability, collision, theft, property damage, etc.

### C. OBTAINING WARRANTY SERVICE

In the event you feel you need to take your RV to an Authorized Dealer for service work of any kind, please first follow the steps below to validate your concern and to obtain service work:

- 1. Verify your complaint.** There is nothing more frustrating than transporting your RV to your Dealer just to find out your RV is operating correctly, is functioning within normal conditions of the RV, or was not used correctly. There are many instances where your Dealer or Brinkley RV can help you before you become frustrated and spend time trying to obtain service.
- 2. Make a list.** If service is truly required, you should also make a prioritized list of all repairs needed and provide this list to the Dealer or Authorized Service Center at the time of scheduling service. We want to ensure that the Dealer or Authorized Service Center schedules enough time to address all your service concerns and they can obtain all necessary parts in advance of your service appointment. The checklist will also help to ensure that the Dealer addresses all your concerns at the time of service.

### + NOTICE

It is very common for service to be delayed due to the parts not being available at the time of service. RV Dealers generally carry many different brands and models of RV's making it difficult to stock all parts required for service. Some replacement parts may take several weeks for the Dealer or Authorized Service Center to obtain. The better you communicate your service needs, the better your service experience will be.



**3. Be prepared.** Prior to calling your Dealer or Brinkley RV, make sure you have your warranty list prepared, the VIN, and any related past service/maintenance paperwork available. Being prepared is critical to ensuring speedy and accurate resolution of your service issues.

**4. Call ahead.** Due to demand, it is best to contact your Dealer to schedule your service appointment several weeks prior to using your RV. Please take into the account that if parts are needed, repair time may be extended. Holiday schedules may also impact scheduling time.

#### **+ NOTICE**

To improve efficiency, any time you reach out to your Dealer or Brinkley RV, please have the name of the individual on the registration, your RV's 17-digit Vehicle Identification Number (located on the A-frame of a travel trailer and on the hitch of a fifth wheel), date of purchase, and a detailed description of your complaint(s).

**5. Drop off your RV.** Dealers will ask for your RV to be dropped off. This will give them time to properly verify your complaint, identify the cause, and make the correction. Note that there are also instances where service may be able to be performed by a mobile technician. Calling ahead to confirm whether drop-off is required will save you time and reduce frustration.

**6. Inspect your RV at pick-up.** Prior to picking up your unit, inspect all repairs thoroughly. It is vital to address any concerns or dissatisfaction immediately. You should feel empowered to ask as many questions as you have related to your RV service as your satisfaction is of the utmost importance. If a problem reoccurs after leaving the Dealership, contact the Dealer's Service Manager along with Brinkley RV, to quickly address and resolve the issue.

## **D. OBTAINING EMERGENCY WARRANTY REPAIR**

Emergency warranty repair while you are traveling includes any issue that: (1) prevents the total use of the RV, (2) poses a safety risk, and/or (3) if not remedied, will result in additional damage to the RV. To help you better understand what constitutes an emergency warranty repair, please see the below examples.

### **EMERGENCY EXAMPLES (Affects safety and/or prohibits use of the RV.)**

- Slide-outs will not extend or retract.
- Damage to axles, running gear, wheels or tires prohibits safe transit.
- Damage to any safety equipment required for safe transit or use.
- Gas leaks of any kind.
- Awning will not retract to permit safe transit.
- Jacks will not retract to permit safe transit.
- Refrigerator does not operate.
- Any other item that, if not remedied immediately, could result in personal injury or property damage.

### **NON-EMERGENCIES (Items that are frustrating, but do not pose safety risks or loss of RV use.)**

- Any cosmetic issues (scuffs, scratches, dings, etc.).
- Components or appliances not functioning properly but do not pose safety risks (TVs, stereo equipment, washer, and dryer, etc.).
- Plumbing leaks that will not further damage the unit if left unresolved.
- Non-functioning power awnings.
- Any other items that do not pose a risk to the health and safety of the occupants and others and do not render the unit unusable or uninhabitable.

## SEC.03 SERVICE & WARRANTY

We understand that non-emergency issues with your RV are still frustrating. However, they should be resolved utilizing the normal service process. Special service priority is given to RVs that require the types of emergency repairs listed above. Should you encounter the need for emergency warranty assistance while in transit, please follow the below process.

### 1. Locate the nearest Authorized Brinkley RV Servicing Dealer

A Dealer Locator Map can be found at [www.brinkleyrv.com/dealer-locator/](http://www.brinkleyrv.com/dealer-locator/) or contact Brinkley RV Customer Care Monday-Friday 7am–5pm EST at (574) 501-4280 or toll free at (888) 502-3460 or via email at [CustomerCare@BrinkleyRV.com](mailto:CustomerCare@BrinkleyRV.com).

### 2. If you are unable to locate a

**local Authorized Dealer**, it may become necessary to use a non-authorized service provider or mobile service. When locating a non-authorized service provider or mobile service, it is best to search online, through resources provided by a local campground, by contacting your Dealer, or with the assistance of the Brinkley RV Customer Care Team.

In emergency situations, if you are unable to make contact with your Dealer or Brinkley RV, please contact.

#### SAFERIDE CONTACT:

**24/7 Roadside Assistance**  
(888) 482-5715

**SafeRide Customer Service**  
(855) 963-1770  
Monday-Friday, 8am–5pm CST

#### + NOTICE

Brinkley RV is more than willing to work through a non-authorized service provider to help you obtain the service that you need. However, please keep the following in mind: (i) Service calls are not covered under warranty, (ii) Brinkley will need to approve the repair estimate PRIOR to the work being performed, (iii) we may choose to ship the needed parts versus permit substitutions or use of locally available alternatives, (iv) defective parts may be required to be returned, and (vi) payment must be made by the Customer and the Brinkley RV pre-approved estimate will be reimbursed post-repair.

**3. If you are able to utilize a local Authorized Dealer or Service location**, please proceed as stated in the process provided in [Section 3C](#) above.

**4. SafeRide RV Motor Club.** As an additional benefit to your ownership of a Brinkley RV, we provide you with complimentary Emergency Service and Roadside Assistance through the SafeRide RV Motor Club for the first twelve (12) months of ownership. This service will be particularly important to you in the event you have need for emergency repairs outside of the normal business hours of your Dealer and Brinkley Customer Care. SafeRide will provide roadside assistance or on-site assistance to temporarily correct a condition that prevents you from towing the vehicle to a service center for repairs.

## + NOTICE

### **SAFERIDE CONTACT:**

#### **24/7 Roadside Assistance**

(888) 482-5715

#### **SafeRide Customer Service**

(855) 963-1770

Monday-Friday, 8am–5pm CST

We are also including the contact information for SafeRide at the bottom of each page of this manual for your ease of retrieving the information if needed. It will also be included on the interior of the unit close to the main entry door.

**WHEN CONTACTING SAFERIDE, THE LAST 8 DIGITS OF YOUR VIN WILL BE REQUIRED TO OBTAIN SERVICES. AS AN EXAMPLE, IF YOUR VIN IS 7T0FG4237N2000001, YOU WOULD NEED TO PROVIDE N2000001 TO THE SAFERIDE AGENT.**

## **E. REPLACEMENT PARTS**

Brinkley RV and its Authorized Dealers and Service Centers are the exclusive providers of parts. As a general rule, we recommend you first contact your selling Brinkley RV Authorized Dealer. If an original part is no longer available, Brinkley RV and/or your Dealer will provide an alternative replacement. As always, we are here to help you. Please contact the Brinkley RV Customer Care Team whenever you feel it is necessary to ensure you get the assistance that you need.

## **F. AFTERMARKET INSTALLATIONS AND ALTERATIONS**

Aftermarket installations or alterations to your RV and its parts and components are not covered under any warranty provided by Brinkley RV or the warranties of its component suppliers.

In addition, such modifications void any warranty to any related part or location that was possibly affected or changed by the modification made. Whoever performed the work for the alterations or modifications holds the sole responsibility and liability of the work performed and any related warranty. Brinkley RV is not responsible for the safety or quality of modifications performed nor its related parts, materials, or workmanship of the provider.

## **G. UPDATING YOUR CONTACT INFORMATION**

Updating contact information and new owner information is vital. In the event the RV was stolen, totaled, destroyed, has changed ownership, or personal contact information has been changed, Brinkley RV should be notified right away.

It is required by federal law that Brinkley RV maintain and keep records of products and Brinkley RV owners. These records ensure we can promptly reach out to current owners in the event of a Recall, Service Campaign, or other necessary Customer notification.

## + NOTICE

To update your contact information, please email [CustomerCare@BrinkleyRV.com](mailto:CustomerCare@BrinkleyRV.com) with the subject line “Contact Information Update” or mail the updated information to:

Brinkley RV  
Attn: Customer Care  
1655 Brinkley Way East  
Goshen, IN 4652

For questions, please contact Brinkley RV Customer Care at (574) 501-4280 or toll free (888) 502-3460.

## SEC.04 OCCUPANT SAFETY

Your Brinkley RV is designed to include the features and functions we believe will help provide the ultimate Customer Experience. Rest assured that the safety of you, your family and your RV are of the utmost importance to us. Your Brinkley RV is designed to meet and/or exceed all safety codes and standards provided by RVIA, or Transport Canada if shipped to Canada, or otherwise required by law at the time it is manufactured.

It is our priority to ensure all safety items are properly and carefully installed to ensure the safety of all occupants within your RV. To further ensure the safety of you and others, please carefully and completely read and understand this Section.

### A. DEVELOP A FAMILY SAFETY PLAN

In case of emergency or severe weather, a Safety Plan should be developed in advance for you, your family, and any other occupants. Be proactive and practice your plan with your RV occupants, especially if children are involved.

1. Prior to using your RV, know where all doors, emergency exit windows, and safety equipment are located.
2. Know where the safety alarms are within your RV, and what it means if they are triggered. Educate everyone on how to properly evacuate the RV. If children are involved, please stress the importance of evacuating the RV with or without an adult in the event of an emergency.
3. Plan a minimum of two (2) ways to evacuate the RV. See also [Section 4D](#) pertaining to Egress Windows for additional information. The first form of exit can include the RV entry door, but the other planned route should not. It may be essential to practice blindfolded. In a real fire situation, smoke may make it difficult, if not impossible, to see.

4. In the case of a fire, make sure everyone knows how to check doors for heat and to leave the door closed if hot; stay low while moving; and avoid inhaling smoke, fumes, and/or gases as much as possible. Placing a cloth over your mouth and nose will assist in protecting you against inhalation of smoke, fumes, or gases.
5. Plan a meeting location near the RV but a safe distance away. Everyone should remain at this location until every occupant is accounted for.
6. Make sure everyone knows how to call 911 from outside the RV and where to go if they do not have a phone. A family emergency contact should also be established and memorized.
7. Safety drills should be discussed and practiced as needed every six (6) months or as frequent as necessary to ensure everyone's safety.

#### **⚠ WARNING**

**WHEN IN A FIRE RISK ZONE, ADHERE TO ALL FIRE AND SAFETY RESTRICTIONS THAT APPLY.**

---

#### **⚠ WARNING**

**BE CAUTIOUS OF THE HEAT INDEX WHEN CAMPING IN HIGH TEMPERATURE CLIMATES. KEEP HYDRATED AND STAY IN AIR CONDITIONED LOCATIONS DURING A HEAT INDEX WARNING.**

---

## B. EMERGENCY WEATHER PLANNING

### 1. General Information

It is very important to monitor weather conditions while camping. Weather is known to change with little to no warning and can put you, the RV, the tow vehicle, and all occupants at risk. Local weather stations broadcasted on TV and radio often provide updated weather conditions and warnings as they occur. Be sure to stay tuned as you are traveling and using your RV. Knowing how to deal with severe weather conditions is important to ensure you and your family's safety. If traveling to an area where weather is known to suddenly shift, a weather radio is recommended.

Weather radios broadcast 24-hour VHF weather observations and forecasts directly from the US National Weather Service (NWS). Frequencies used by the US National Oceanic and Atmospheric Administration (NOAA) weather radio are 162.400, 162.425, 162.450, 162.475, 162.500, 162.525, or 162.550 megahertz (MHz). You can also visit their website at [www.noaa.gov](http://www.noaa.gov).

### WARNING

**DURING SEVERE WEATHER CONDITIONS SEEK SHELTER INDOORS OR AS DIRECTED BY THE CAMPGROUND AND/OR APPROPRIATE LOCAL AUTHORITIES.**

### + NOTICE

Many emergency shelters do not permit the entry of pets due to health-related reasons and limited space. You as the owner are responsible to create a safety survival plan for your beloved pets. It is also recommended that the plan include a three (3) day supply of food and water for all occupants.

## 2. Repairing Severe Weather Damage

Please contact your insurance provider right away if your RV is damaged by severe weather. Contacting your insurance provider is required **PRIOR** to the repair(s) being scheduled and/or performed. Weather damage is covered exclusively by your insurance coverage and is not covered by Brinkley RV or its component manufacturers.

## C. FIRE SAFETY

### 1. General Information

The most common fire safety issues include, but are not limited to, smoking in bed, using flammable solvents and/or cleaning fluids, and leaving children unattended.

### 2. Fire Emergencies

**IN A FIRE EMERGENCY, EVACUATE THE RV FIRST, THEN CALL 911 FROM A SAFE LOCATION.**

- In a fire emergency, execute your Family Safety Plan as outlined in [Section 4A](#).
- Ensure everyone knows to stop, drop, and roll if their clothes or hair catch on fire. The basic protocol for stop, drop and roll is as follows:
- **STOP** in place, do not run.
- **DROP** to the ground.
- **ROLL** back and forth, with your hands shielding your face from the flames.



## SEC.04 OCCUPANT SAFETY

### 3. Common and Important Fire Safety Information

Below is a list that includes common information related to fire safety. This list is not all inclusive of all rules related to fire safety. Common sense and attention to your surroundings may dictate additional guidance and protections that are required to prevent the spread of fire. Please use this list as a guide to ensure that fire safety is **ALWAYS** practiced by you, your family and other occupants of your Brinkley RV:

- **ALWAYS** supervise children around or near any open flames, especially grills, fire pits and campfires.
- **ALWAYS** learn and teach fire safety, prevention, and fire extinguishing practices.
- **ALWAYS** build campfires, place grills, or otherwise utilize open flames away from nearby trees or bushes and adhere to all federal, state and local laws related to fires and burning, including local burning bans and advisories. It is critical to always know and adhere to the restrictions in place for your location. Forest and field fires can be catastrophic to safety and property alike and can quickly spread.
- **ALWAYS** maintain at least a three (3) feet of clearance around grills, campfires, your RV, tents, and other structures or combustible materials. This three (3) foot zone should be free of leaves, dry grass, pine needles, or any other combustible substances to prevent the spread of fire.
- **ALWAYS** proactively have an action plan in place to rapidly and completely extinguish a campfire or other open flame.
- **ALWAYS** teach family members and RV occupants how to locate and properly use the fire extinguisher.
- **ALWAYS** replace your fire extinguisher as recommended by the manufacturer of the extinguisher.
- **ALWAYS** call the Fire Department, no matter how small the fire may seem.
- **ALWAYS** assume that, where there is smoke, there may be fire.
- **NEVER** store combustible materials in enclosed areas or near any heat source.
- **NEVER** leave a fire burning unattended. An ember or unextinguished cigarette can cause a fire to quickly spread out of control during dry conditions.
- **NEVER** use water to put out a grease or electrical fire. Utilizing water can spread grease fires and can create an electrocution or shock hazard during an electrical fire.
- **NEVER** assume that your family and other RV occupants are aware of and practice fire safety. It is your responsibility to ensure that everyone is prepared in the event of fire.

**Additional information pertaining to fire safety and firefighting can be located at the National Fire Protection Association (NFPA) website [www.nfpa.org](http://www.nfpa.org).**

#### + NOTICE

Notify Brinkley RV immediately if you feel that a product failure resulted in a fire. Please call Brinkley Customer Care at (574) 501-4280 or toll free (888) 502-3460 for approval before you re-enter the RV, have it moved or repaired, or any debris is removed or cleaned from the unit. A failure to notify Brinkley RV in advance could result in a loss of warranty coverage.



## 4. Fire Extinguishers

### a. General Information

Fires can spread rapidly. Prior to reaching for the fire extinguisher, remember your Family Safety Plan. See [Section 4A](#) and remember that safety is the priority. Property can be replaced. People and pets cannot. If a fire starts in or around your RV,

**SAFE EVACUATION OF ALL OCCUPANTS FROM THE RV IS THE FIRST AND UTMOST PRIORITY.**

A dry chemical, Class B/ Class C type fire extinguisher is located near the entry door of your RV. The provided portable fire extinguisher should be utilized on small fires or to help contain larger ones until the fire department arrives on site. Portable extinguishers do have limitations and remember to always put your safety first.



Household fire extinguishers are classified into four types by Underwriters Laboratories (UL):

| RATING   | INTENDED USE   |
|----------|--|
| TYPE A   | FOR USE ON FIRES INVOLVING COMBUSTIBLE MATERIALS SUCH AS WOOD, CLOTH AND PAPER.                    |
| TYPE B   | FOR USE ON FLAMMABLE LIQUID FIRES, INCLUDING KITCHEN GREASE. NEVER USE WATER ON THIS TYPE OF FIRE. |
| TYPE C   | FOR USE ON FIRES INVOLVING ENERGIZED ELECTRICAL EQUIPMENT.   |
| TYPE ABC | WORKS ON ALL THREE TYPES OF FIRES LISTED ABOVE.  |

### b. Operation

When utilizing a fire extinguisher, it is vital to keep your back facing a clear and safe exit to maintain a safe escape route. Stop and evacuate immediately if the fire cannot be contained or if smoke fills the room.

**TO OPERATE A FIRE EXTINGUISHER, REMEMBER THE WORD: P.A.S.S.**

- PULL** the pin. Hold the extinguisher with the nozzle pointing away from you and release the locking mechanism.
- AIM** low. Point the extinguisher at the base of the fire.
- SQUEEZE** the lever slowly and evenly.
- SWEEP** the nozzle from side-to-side until the fire is out.



### c. Disposal

For disposal of used fire extinguishers, contact your local fire, sanitation, or environmental protection department for rules and regulations applicable to their safe disposal.

## SEC.04 OCCUPANT SAFETY

### D. EMERGENCY EGRESS WINDOW(S)

#### 1. General Information

The entrance door is and should be your primary exit. In a situation where the entry door has been compromised, **the Emergency Egress Window (or exit window) should be your secondary exit route. All egress windows are clearly marked with an 'EXIT' label and have red handles for window operation.** See the picture below as an example. Some egress windows include the entire window. There are instances, however, where only a part or portion of the window is intended for egress. It is important to learn the proper use of all Emergency Egress Windows and practice how to operate them prior to an emergency occurring.



Please review and follow the additional information below:

- **ALWAYS** ensure the Egress Windows are not blocked by trees and/or any other obstacles when setting up your campsite.
- **ALWAYS** ensure that the ground around the outside of the RV at the egress window location(s) provides solid ground and an easy escape route.
- **ALWAYS** review proper escape routes in case of an emergency.

- **ALWAYS** locate all Egress Windows and review proper operation with all occupants within the RV.
- **ALWAYS** determine in advance the order of who will exit through the egress window and how it will be performed.
- Before exiting an Egress Window, if possible, place a blanket over the frame for protection.
- **ALWAYS** ensure that the last person to exit the RV, in the case of a fire, knows how to help others escape.
- **ALWAYS** ensure that all occupants of the RV know the predetermined meeting location if an emergency ensues.

#### 2. Maintenance

To prevent the Egress Window seals from sticking, periodically open and close the windows. Before traveling, always make sure ALL windows are locked. It is important to ensure that all locks work properly and that Egress Windows operate properly prior to using the RV. Failing to lock windows prior to transit may result in wind damage to the windows.

### E. SMOKE ALARM

#### 1. General Information

On the ceiling of your RV, you will notice a smoke alarm in the main living area. The smoke alarm is intended to alert you as soon as smoke is detected to reduce the risk of personal injury, property damage, or even death from smoke and/or fire. Although smoke alarms are intended to provide you with enough notice and time to escape before a fire spreads, it is important to understand they are not foolproof. Smoke alarms will only be triggered when smoke reaches their sensors. Although a smoke alarm is a necessary safety alert system, common sense and your own



senses should be utilized to ensure the safety of you, your family, and any RV occupants at all times.

- It is crucial for smoke alarms to be properly located, installed, and maintained.
- Smoke alarms should not be tampered with and should be inspected on a continuous basis.
  - When the smoke alarm battery is supplying power, a red LED light will flash.
  - If the light is not flashing or if the alarm is chirping, the battery should be changed immediately.
  - A smoke alarm will not function correctly if the battery is missing, installed incorrectly, or is not the correct battery type.
  - If the battery is correctly replaced, and the alarm is still not functioning, replace the alarm.
- If smoke is detected by the alarm, it will trigger the audible alarm until the air is cleared.
- Those who have loss of hearing or specific medical conditions relating to hearing loss should consider using alarms that offer both audible and visual signals. Smoke detectors with visual alarms are **NOT** installed in your Brinkley RV from the factory.

#### IF THE SMOKE ALARM SOUNDS:

When the alarm is triggered, a loud repeating alert or siren will sound and the light on the smoke alarm will rapidly flash red.

- The alarm signals that smoke has been detected and requires your immediate attention.
- Never ignore an alarm if it is triggered. Doing so may result in injury or death.

- When the alarm is triggered and it is evident there is a fire, evacuate the RV immediately.
- After you are a safe distance from the RV, call 911.
- Always refer to your Family Safety Plan and ensure all occupants know the plan.

#### **WARNING**

**Smoke alarms DO NOT function without a working battery. DO NOT disconnect the battery to silence the smoke alarm and ALWAYS make sure the alarm is working for continuous protection.**

#### **WARNING**

**Test all smoke alarms before every camping trip or use of your RV. This is especially important after your unit has been removed from storage and any time you have not utilized the RV for an extended period.**

#### **WARNING**

**Never use an open flame, such as a lighter or match, to test a smoke alarm. Doing so may result in setting fire to the smoke alarm and your RV. Always use the “Test” button on the alarm. If the smoke alarm does not signal right away, check the battery and replace the alarm as needed.**

## 2. Testing a Smoke Alarm

It is vital for smoke alarms to be tested on a weekly basis. When testing, stay an arm’s length away from the alarm to make sure the alarm’s signal does not injure or harm your hearing during the test.

## SEC.04 OCCUPANT SAFETY

### SMOKE ALARM TESTING PROCEDURE:

1. **PRESS** and **HOLD** the **TEST/SILENCE** button found on the face of the alarm until the alarm sounds. The alarm may continue for a second or two after the **TEST/SILENCE** button is released.
2. If the alarm does not sound right away, check the power source (its battery) and then conduct the test again.
3. If the alarm still does not signal, **CHECK** and ensure the alarm is clean of dust and debris.
4. If the alarm still does not operate, it should be replaced immediately.

### 3. Maintenance

To keep the smoke alarm functioning properly:

- **NEVER** clean alarms with solvents, cleaning products, water, bleach, or any other substance that may damage the alarm.
- Carefully wipe with a clean rag or vacuum the smoke alarm at least once a month.
- **NEVER** paint the smoke alarm. Paint may clog or damage the opening of the sensing unit and prevent the alarm from functioning properly.

## F. CARBON MONOXIDE (CO)

### 1. General Information

Carbon monoxide (CO) is a colorless, odorless, tasteless, gas produced by the exhaust of burning fuel or the incomplete combustion of carbon. Sources of CO in or around your RV may be the exhaust from vehicles, generators, heaters, gas stoves and ovens, furnaces, portable grills, and/or any other gas-powered object or appliance.

CO can be poisonous even at low levels of concentration. With exposure to CO, victims tend to first experience nausea, dizziness, a dull headache, weakness, and confusion. In many situations, CO victims dismiss the early warning signs as just not feeling well and become disoriented to the point they are unable to escape or call for help. Signs and symptoms of CO poisoning will first be observed in young children and pets and should not be ignored. Immediate action is required.



THE CO AND PROPANE GAS ALARM.  
SEE [SECTION 46](#) FOR ITS LOCATION IN THE RV.

### CARBON MONOXIDE (CO) POISONING SIGNS AND SYMPTOMS:

- **Mild exposure:** Dull headache, running nose, weakness, sore or watery eyes, and/or other flu-like symptoms.
- **Medium exposure:** Dizziness, drowsiness, and/or vomiting.
- **Extreme exposure:** Unconsciousness, brain damage, and/or death.

Discuss the signs and symptoms of CO poisoning with all family members.

### ⚠️ WARNING

Many carbon monoxide victims dismiss the early warning signs as just not feeling well and become too disoriented and are then unable to escape or call for help. **NEVER** avoid early warning signs. Doing so may result in brain damage or possibly death.

### ⚠️ WARNING

If there are other vehicles or generators running nearby, there is a chance for exhaust fumes to enter into your RV. The best protection against carbon monoxide is proper ventilation and the use of a Carbon Monoxide Alarm. To maintain proper ventilation within your RV, make sure the vents on all ventilation systems are clear of snow, leaves, or any other possible debris.

## 2. Carbon Monoxide (CO) Alarm

### a. General Information

Carbon Monoxide Alarms will sound when the CO reaches a potentially dangerous level within your RV. Upon hearing this alarm, you should quickly evacuate your RV and remain clear of the unit until the RV is well ventilated and the alarm discontinues.

- It is crucial for CO alarms to be properly located, installed, and maintained.
- CO alarms should not be tampered with and should be inspected on a continuous basis.
- When the battery is supplying power, a red LED light will flash.
- If the light is not flashing or if the alarm begins chirping, the battery should be changed immediately.
- A CO alarm will not function correctly if the battery is missing, installed incorrectly, or is the wrong type.
- If the battery is correctly replaced, and the alarm is still not functioning, replace the alarm.

- If CO is detected by the alarm, it will trigger the audible alarm until the air is cleared. For those who may have loss of hearing or specific medical conditions relating to hearing loss, should consider using alarms that offer both audible and visual signals.

### IF THE CARBON MONOXIDE ALARM SOUNDS:

#### 1. Ventilate the RV IMMEDIATELY.

Open all possible doors and windows.

- a. **CHECK** that all occupants are accounted for.
- b. **CALL 911** for your local emergency service or fire department.
- c. **DO NOT** re-enter the RV and stay clear from its openings until the emergency responders arrive or until the CO alarm ceases due to proper ventilation and removal of the CO from the RV.

#### 2. Confirm that another motor vehicle or nearby RV is NOT the source of the CO.

#### 3. If the CO alarm signals again within a 24-hour period:

- a. **REPEAT** step 1 in its entirety.
- b. **BEFORE** continuing use of your RV, **CALL** a qualified appliance technician to inspect all appliances utilizing gas and their associated gas lines to investigate the sources of carbon monoxide entry.
- c. **IF PROBLEMS ARE IDENTIFIED** during the inspection process, service the equipment **IMMEDIATELY** and **DO NOT** continue use of your RV until repairs are completed.
- d. **NOTE** all combustion equipment not inspected and provide maintenance as needed per the supplier component manuals.

### ⚠️ WARNING

CO alarms **DO NOT** function without a working battery. **DO NOT** disconnect the battery to silence the CO alarm and **ALWAYS** make sure the alarm is working for continuous protection.

---

#### b. Testing the CO Alarm

It is vital for CO alarms to be tested on a weekly basis. When testing, stay an arm's length away from the alarm to make sure the alarms signal does not injure or harm your hearing. Below are the testing instructions.

#### TESTING THE CO ALARM:

- Press and hold the **TEST/SILENCE** button found on the face of the alarm until the alarm flashes red. Once flashing, the alarm will then signal 4 times and repeat for 5-6 seconds.
- If the alarm does not signal in this manner, check the power source and then test again.
- If the alarm still does not signal, **CHECK** and ensure the alarm is clean of dust and debris.
- If the alarm still does not sound, replace the CO alarm immediately through your Dealer.

### ⚠️ WARNING

**DO NOT** remain within close proximity of alarm when sounding. Exposure within close range may be harmful to hearing. When testing, stay at arm's length away.

---

### ⚠️ WARNING

Never test the CO alarm with vehicle exhaust or any other form of exhaust. This may lead to permanent damage and voids your warranty. This may also lead to personal harm.

---

### ⚠️ WARNING

Test all CO alarms before every camping trip or use of your RV. This is especially important after your unit has been removed from storage. If the CO detector fails to test correctly, replace it immediately. Failure to do so may result in brain damage, injury, or death.

---

### ⚠️ WARNING

The CO alarm sounding indicates potentially toxic levels of carbon monoxide which may result in brain damage or death. CO alarms will only indicate carbon monoxide is present at the sensor and does not indicate CO in other possible areas.

---

### + NOTICE

Replacing the CO alarm yourself can void the warranty. Be sure to use your Authorized Dealer while under warranty.

---

#### c. CO Alarm Maintenance

To keep the CO alarm functioning properly:

- **NEVER** clean alarms with solvents, cleaning products, water, bleach, or any other substance that may damage the alarm.
- **ALWAYS** carefully wipe the CO alarm with a clean rag or vacuum the smoke alarm at least once a month.
- **NEVER** paint the CO alarm. Paint may clog or damage the opening of the sensing unit and prevent the alarm from functioning properly.



## G. PROPANE GAS (LP) ALARM

### 1. General Information

Propane gas is used in many of the appliances within your RV. Examples include, but are not limited to, the furnace, water heater, ovens and cooktops, portable grills, etc. If a leak occurs, because propane is heavier than air, it will collect in lower areas. Because of this, a Propane Gas Detector is installed near the floor line of your wall in an open area.



- It is crucial for propane detectors to be properly positioned, CO and LP Gas Alarm installed, and maintained.
- Propane detectors should not be tampered with and should be inspected on a continuous basis.
- When the LED on the front of the detector is green, the alarm is active. If propane, acetone, alcohol, butane, and/or gasoline is detected by the detector, it will trigger the alarm until the air is cleared. Such chemicals can be found in deodorant, perfume, cologne, wine, adhesive, liquor, lacquer, kerosene, the propellants of aerosol cans, and most cleaning agents.
- Those who have loss in hearing or specific medical conditions relating to hearing loss should consider using alarms that offer both audible and visual signals. Alarms with visual alarms are **NOT** installed in your Brinkley RV from the factory.



### IF THE PROPANE GAS DETECTOR IS ALARMED:

1. Immediately **EXTINGUISH** all flames, smoking materials, and **SHUT OFF** all gas related appliances such as the stove, heater, furnace, refrigerator, etc. **DO NOT** touch any electrical switch, use electronic devices or appliances, or cellular devices.
2. **EVACUATE** everyone from the RV immediately. Use your Family Safety Plan to safely evacuate everyone from the RV. See [Section 4A](#).
3. **OPEN** all door(s) and windows to ventilate the RV.
4. **SHUT OFF** all gas supply at the LP tank valve and any other provided source. **DO NOT** start any vehicle engine, open flame, or generator near the RV.
5. **DETERMINE & REPAIR** the source of the leak.
6. **DO NOT RE-ENTER THE RV UNTIL THE PROBLEM IS CORRECTED.**

# SEC.04 OCCUPANT SAFETY

**PRIOR TO USING THE LP SYSTEM OR ANY LP RELATED APPLIANCE, CONTACT YOUR DEALER OR A PROPANE GAS EXPERT TO CORRECT THE PROBLEM.**

## **⚠ DANGER**

The sounding of this device means that there is a presence of LP gas, which may result in fire and/or an explosion. Leaks generally occur in LP gas piping and/or the LP gas appliances. Follow all information found within the supplier component manuals. Failure to do so may lead to carbon monoxide poisoning, fire, and/or an explosion causing property damage, personal injury, or death.

## **⚠ WARNING**

High temperatures reactivate glues and adhesives within your RV and create a vapor. If a unit is closed on a hot day, the chemicals and vapors can collect creating a toxic level detectable by the Propane Gas detector.

## **H. INDOOR AIR QUALITY**

### **1. Maintaining Indoor Air Quality**

- **ALWAYS** provide proper ventilation within your RV.
  - Proper ventilation carries pollutants and emissions out of your RV.
  - Poor ventilation will cause air pollutants to gather and potentially reach dangerous, toxic levels. Heat and humidity can cause this occurrence to accelerate.
- Clean the RV on a regular and frequent basis.
- Be proactive to protect against harmful air pollutants. These include but are not limited to: molds, pet dander, cleaning agents, pollen, and carbon monoxide from the use of charcoal, propane, or other fuel types.

## **+ NOTICE**

Children, the elderly, and those with allergies, asthma, heart disease, and/or with chronic lung disease are at the greatest risk for reactions to poor air quality.

### **2. Improving Indoor Air Quality**

- Open windows and doors so fresh air is available inside your RV.
- Spend time outside.

### **CONTROL MOLD, ALLERGENS, AND OTHER SPORES:**

- Fix any water leaks immediately as they are found.
- Properly ventilate the RV.
- Clean on a regular basis removing dust, dander, pet fur, water, etc.
- Do not allow water or moisture to collect within the RV.
- Keep the windows closed and periodically run your air conditioner (A/C) and/or a dehumidifier (Customer Supplied).
- Clean any mold or mildew immediately that can be seen or smelled with proper solutions. We recommend one (1) cup (236.6 ml) bleach to one (1) gallon (3.785 liters) of water as a cleaning agent.

## **+ NOTICE**

Never mix cleaning agents that can cause chemical reactions (ex: bleach and ammonia). Do not smoke within your RV or near an entry point into your RV. Do not use bug spray within your RV.

### 3. EPA Recommendations

The Environmental Protection Agency (EPA) provides and recommends three (3) basic strategies to improve indoor air quality within your RV:

- **Remove sources.** By eliminating sources of pollution and their possible emissions, you will effectively improve indoor air quality. This strategy is important and effective for the following pollutants:
  - **Biological Contaminants:**  
bacteria, molds, mildew, spores, viruses, dander, and pollen.
  - **Household Products:**  
Cleaning agents, disinfectants, cosmetic products, paints, and varnishes.
  - **Pesticides or other chemicals.**
  
- **Ventilation.** Proper ventilation increases fresh airflow within the RV and lowers the concentration of pollutants present. Open doors, windows, and vents to allow fresh air to flow through your RV. Operating fans, air purifiers, and the RV air conditioner(s) or furnace also helps to bring in fresh air and force out stale, polluted air.
  - When the RV remains closed, airflow decreases increasing the presence of air pollutants.
  - Follow the recommendations within this manual to assist in avoiding exposure to air pollutants and outgassed chemicals.
  
- **Air Cleaners.** Air cleaners are designed to remove specified pollutants from the air. Their effectiveness depends on how well they are capable of collecting pollutants within their filters. An effective air cleaner requires an intake, proper filters, and a high air circulation return rate. Being that there are many types on the market, it is important to thoroughly research the product.

Many smaller, less expensive models are not as efficient with particle removal. Most common air cleaners DO NOT remove gaseous pollutants.

#### + NOTICE

Chemical outgassing is a normal process that occurs and is not a defect within your RV. Please follow the recommendations within [Section 4H\(4\)](#). Given that outgassing is normal and to be expected, it is not covered under any warranty provided.

### 4. Chemical Sensitivity and Outgassing

#### a. General Information

Upon purchasing a new RV, you may notice a chemical odor due to outgassing. More commonly, you will notice this after the RV has been closed up for a period of time. This is normal, and not a defect.

“Outgassing” is the release of gas or chemical vapor that was once trapped, frozen, dissolved, or absorbed within a material. This tends to occur in new RV’s and will lessen over time as the materials acclimate and outgas.

Like a home, your RV is constructed using materials including, but not limited to linoleum, carpet, insulation, plywood, upholstery, and other common building materials. Being that these materials differ in chemical make-up from one another, it is to be expected they will outgas various chemicals, including formaldehyde. Increased temperatures and humidity will increase the outgassing process.

Being that RV’s are much smaller than a home, the air exchange within an RV is greatly reduced. Minimal air exchange makes the smell of outgassed chemicals more exaggerated and noticeable.

## + NOTICE

If not properly ventilated, chemical sensitivity such as eye, nose, and throat irritation along with nausea, headache, or other asthma-like symptoms may occur. Children, the elderly, and/or those with a history of lung-related problems may be more susceptible to the effects of the outgassing process.

### b. Formaldehyde

Formaldehyde is a naturally occurring substance that is used widely in building materials such as plywood, pressed wood, paneling, and medium density fiberboard (MDF), all of which are commonly used within the RV construction. Because formaldehyde is contained within some of the materials used within your RV and some people have sensitivity towards the chemical, it is important you properly ventilate your RV as instructed in [Section 4H](#).

### c. California Air Resource Board (CARB) Notice

Formaldehyde is used widely in building materials such as pressed wood products, particleboard, hardwood plywood paneling, medium density fiberboard (MDF), and plywood which are commonly used throughout the Recreational Vehicle Industry. As mandated by the RV Industry, Brinkley RV's contain composite wood products (hardwood plywood, particle board, and MDF) that comply with the California Air Resource Board (CARB) formaldehyde emission standards under California Code of Regulations § 93120.2(a) Phase 2 (P2).

## + NOTICE

Brinkley RV is compliant with the EPA Formaldehyde Standards for Composite Wood Products under Title IV of Toxic Substances Control Act and the California Air Resource Board (CARB) formaldehyde emission standards under California Code of Regulations § 93120.2(a). These can be found at <https://www.epa.gov/formaldehyde/formaldehyde-emission-standards-composite-wood-products> and <https://ww3.arb.ca.gov/research/indoor/formaldehyde.htm>.

## 5. Condensation and Moisture

### a. General

When staying in your RV for extended periods, condensation may occur within your RV if precautions are not properly taken. "Condensation" refers to when vapors found in humid air collect as water. Commonly, this will form in out-of-sight locations such as inside cabinets, closets, on ceiling panels, etc. Not only can condensation cause damage to your RV, it can also damage your personal belongings. When not properly controlled, condensation is often misconstrued as a water leak.

To minimize condensation within your RV, proper ventilation should be practiced. The use of a dehumidifier (Customer Supplied) is recommended if proper ventilation is not obtainable or if there is high humidity in the ambient air.

### b. Controlling Condensation

To reduce moisture within your RV, please do the following:

- Ventilate the RV as often as possible.
- When bathing, showering, drying hair, etc. within the bathroom, keep the bathroom door closed and open the roof vent with the fan on.



The exhaust fan should be left on until all excess moisture exits the RV.

- When cooking, keep the microwave or range exhaust fan on (If Equipped). Cooking releases heat and moisture that may allow condensation to quickly build.
- **DO NOT** hang wet clothes inside your RV to dry.
- Keep a constant source of airflow within your RV to prevent condensation and mildew from forming. (i.e., fan, A/C, air purifier, dehumidifier).
- Keep temperatures cool and constant throughout the RV, including in cabinets, closets, and drawers.
  - While storing your RV, leave cabinets, closet doors and drawers partially open.
  - On an extended stay, periodically open closed off areas such as closets, cabinets, and drawers to allow ventilation.

#### + NOTICE

Cabinets, closets, and drawers filled with stored goods and items will prevent circulation and may lead to condensation.

#### c. Hot Weather Conditions

When traveling in areas of high temperature, start the air conditioner (A/C) early in the day to help remove humidity while lowering the temperature in the RV. This will help prevent condensation and water accumulation leading to possible damage.

#### d. Cold Weather

- During cold weather, utilize your vents and exhaust fans on a continuous basis. This will help to lessen the amount of moisture in the air. Keeping your RV closed up during cold conditions will increase the amount of condensation build-up within your RV.

- Manage inside temperatures accordingly. As you increase the temperatures within your RV and as the temperatures outside fall, this temperature differential will cause condensation to accumulate in areas that are not insulated as well as others (i.e., windows, vents, wall studs, etc.).

### 6. Where There Is Moisture, There May Be Mold

#### a. General

“Molds” are microscopic organisms that can virtually live in any environment and under any condition. Mold requires a source of moisture (i.e., high humidity, wet/damp materials, standing water) to thrive and can grow in temperatures between 40° and 100° Fahrenheit (4.44° and 37.78° Celsius respectively).

According to the Center for Disease Control (CDC), exposure to damp and moldy environments may cause a variety of health-related concerns:

- For those sensitive to molds, exposure may result in coughing, wheezing, nasal congestion, and/or irritation of the eyes, throat, and/or skin.
- Those allergic to molds or who have compromised immune systems or lung-related conditions may have more severe reactions to exposure.

Mold can be harmful to many materials within your RV, especially natural wood products and fabrics. Please follow the tips below to help control moisture within your RV and the prevention of mold and mildew growth:

- When bathing, showering, drying hair, etc. within the bathroom, keep the bathroom door closed and open the roof vent with the fan on. The exhaust fan should be left on until all excess moisture exits the RV.

## SEC.04 OCCUPANT SAFETY

- When cooking, keep the microwave or range exhaust fan on (If Equipped). Cooking releases heat and moisture that may allow condensation to quickly build.
- **DO NOT** hang wet clothes inside your RV to dry;
- Keep a constant source of airflow inside your RV to prevent condensation and mildew from forming. (i.e., fan, A/C, air purifier, dehumidifier).
- Ventilate your RV as often as possible.

### b. Mold Prevention

To help with the protection against mold within your RV, follow the below preventative measures:

- Regularly clean high traffic areas that have water present including the kitchen, bathroom, and convenience center (See [Section 21L](#) for information on the convenience center). On safe surfaces, mold and mildew cleaning agents are recommended.
- Clean and dry all standing water and spills immediately.
- Remove all damp items within your RV.
- Check sealants regularly. Reseal as needed to avoid water leaks.

### I. COLD WEATHER USE

When using your RV near freezing or below freezing temperatures, the following precautions **MUST** be taken:

- Water sources such as the freshwater and drainage systems require added protection against freezing.
- Sufficient power and propane are required to run your furnace to prevent possible freezing.

- Sufficient fuel for generator use (If Equipped), if camping in remote locations without shore power.
- Proper ventilation should be practiced helping reduce condensation. A dehumidifier (Customer Supplied) may be required if ventilation is not sustainable.
- Prior to operating slide-outs, compartment doors, locks, windows, vents etc., check for ice to avoid possible damage from occurring.

### + NOTICE

Brinkley RV's are not manufactured for sub-zero temperatures.

### J. WEBSITES OF INTEREST

We also recommend that you visit the following websites that maintain information about indoor air pollutants, including molds and formaldehyde, along with ways to improve indoor air quality:

- [www.epa.gov/indoor-air-quality-iaq/inside-story-guide-indoor-air-quality](http://www.epa.gov/indoor-air-quality-iaq/inside-story-guide-indoor-air-quality).
- [www.epa.gov/mold](http://www.epa.gov/mold).
- [www.atsdr.cdc.gov](http://www.atsdr.cdc.gov).

### WEBSITE DISCLAIMER OF WARRANTY

Brinkley RV holds no liability whatsoever in connection with the services, information, and/or materials provided within the websites and/or external links noted in this manual.

This information is provided "AS IS" and is for informational purposes only. The use of this information provided is at your own risk. Brinkley RV is not liable for any possible errors,

inaccuracies, or omissions that may be present within the information regardless of the delivery of information, decisions made, or actions taken/not taken in reliance to the furnished external information.

Brinkley RV accepts no liability or responsibility whatsoever regarding the information provided on any external source linked or provided within this manual. This information is meant to be taken as general knowledge and not intended to address any specific situation for any given individual or entity.

Brinkley RV has no control over any external links provided and does not hold responsibility if the information is not fully comprehensive, accurate, complete, and/or up to date.

Brinkley RV has no liability for any loss and/or injury caused, in whole or part, by the actions, negligence, and or omissions of any contingencies beyond its control for compiling, delivering, or obtaining any information. This information is not to be considered professional nor shall it comprise legal advice.

## DISCLAIMER OF ENDORSEMENT

References that may be made within the external or third-party links such as specific commercial products, processes, or goods specific to trademark, manufacturer, or otherwise, shall not be taken as recommended, favored by, as or endorsement by Brinkley RV.

Brinkley RV does not exercise any form of editorial control over the information found within any provided external location. Brinkley RV is not responsible for the content within such external sites and does not warrant, guarantee, or endorse any referenced products, services, information, schools, or goods described or offered within these sources.

## K. ADDITIONAL SAFETY PRECAUTIONS

### 1. Generators

The generators built specifically for RV's should be the only type used within your Brinkley RV. It is important to only operate a generator (If Equipped or Customer Supplied) in an open, outdoor area to permit the exhaust to dissipate. When using a generator, be sure to close all windows, compartments, and entry doors to prevent carbon monoxide from entering your RV. Please refer to [Section 4F](#), for carbon monoxide warnings and additional detail.

#### + NOTICE

Generators are not intended to power sensitive electronics without using the appropriate protections such as a line conditioner and surge protectors. Sensitive electronics in need of protection include, but are not limited to, computers, TVs, printers, audio equipment, and video gear. Such electronics should only be operated on inverter-based generators or pure sine wave generators.

### 2. Loading and Weight Distribution

- **NEVER** surpass the RV's Cargo Carrying Capacity or Gross Vehicle Weight Rating.
- **ALWAYS** distribute the cargo weight evenly throughout the RV.
- **ALWAYS** position heavy items on the floor in the center (closest to the axles) of the RV.
- **ALWAYS** balance weights front-to-rear and side-to-side.

## SEC.04 OCCUPANT SAFETY

### 3. Passenger Safety

**NEVER** allow a passenger to ride inside your RV while in motion. This is against the law in many states and for safety reasons should be avoided.

### 4. Propane Appliances and Equipment

- **ALWAYS** turn **OFF** all propane and gas related appliances and equipment (including tanks) **PRIOR** to transporting your RV.
- **ALWAYS** know and understand all propane and gas related safety warnings and follow all manufacturer recommended operating procedures.

#### **⚠ WARNING**

**Fuel of any sort is highly flammable. Improper use may result in a fire or explosion leading to property damage, injury, and/or possible death.**

---

### 5. Tire Pressure

**ALWAYS** check tire pressures **PRIOR TO** transporting your RV, even for short distances. For proper tire inflation pressures, refer to the Tire Information Label. The Tire Information label is located on the driver side of the unit, in front of the LP compartment, and typically above the Federal ID (VIN) tag. See [Section 5C\(4\)](#).

### 6. Towing

- **ALWAYS** follow posted speed limits but never exceed 65 miles per hour (104.6 km/h).
- **ALWAYS** respond appropriately to weather and/or road conditions that may impact stability, handling, and towing of your RV and tow vehicle.
- **ALWAYS** be aware of your surroundings.

### 7. Wheel Torque

- **ALWAYS** check the torque on all lug nuts **PRIOR TO** departing on any trip, including short distances. For lug nut torque specifications and patterns, refer to [Section 5J](#).
- **ALWAYS** use a calibrated torque wrench to confirm torque.

#### **⚠ WARNING**

**RV's can sway and fishtail in high crosswinds or when exposed to external forces created by large vehicles as they pass. If caution is not exercised, control of the RV and tow vehicle can be lost resulting in serious damage, injury, and/or death. Under such conditions, it is imperative to slow down and pay attention to other vehicles and your surroundings.**

---

## A. GENERAL

Traveling can be stressful. To reduce stress, we recommend using updated maps or GPS navigation to ensure your route utilizes the most up to date information. Call ahead to obtain tourist information in the areas you will be visiting. To ensure safety, make sure your designated camping area and planned adventures comply with all federal, state, and local rules and regulations.

- While away from your home, have someone you trust periodically check on your residence. If you plan to travel for more than two (2) weeks, consider contacting your local police in advance to keep surveillance of your home.
- Carry secondary keys for vehicles and your house on a separate key ring to prevent them from being lost.
- Ensure your driver's license is updated and valid. Renew your license in advance if it will expire during your travels.
- If you plan on visiting other countries, be sure to contact the border control nearest to your planned point of entry to obtain current entry rules and regulations (including rules for re-entering the United States).

### + NOTICE

Always carry your vehicle registration, insurance policy card(s), and warranty registration.

## B. TOW VEHICLE DISCLAIMER

Your tow vehicle's Towing Capacity **MUST BE GREATER** than the Gross Vehicle Weight Rating (GVWR) of your RV. If you do not know your Towing Capacity or if you are considering purchasing a new tow vehicle, contact your automotive manufacturer

or Dealer to obtain the towing specifications of the prospective vehicle(s). Be aware that some vehicles can be purchased with optional towing packages.

Some automotive manufacturers have brochures for their products that contain towing capabilities and specifications. This information should be reviewed to verify weight ratings and limitations. Make sure you are looking at your exact model, year, engine, transmission, etc., to ensure you are receiving accurate information.

### + NOTICE

Brinkley RV shall not be liable for any damages that may be incurred by the Customer, owner, or driver of a Brinkley RV as a result of the operation, use, and/or misuse of a tow vehicle.

## C. VEHICLE LABELS

Throughout your RV, labels and data plates are present containing information pertaining to safe operation, service instructions, RV specifications, and warnings. Be sure to read all provided labels, decals, and data plates before operating your RV. If any label within your RV is damaged, painted over, or removed, they should be replaced right away.

### 1. Weight Ratings and Definitions

It is vital to remain within the weight rating specifications of your RV and tow vehicle. Failure to do so may result in loss of warranty, damage to your tow vehicle, or damage to your RV. More critically, failure to adhere to weight limitations poses great danger to you and those around you when operating or towing your RV. Vehicle and RV weights fall into two categories:

- **Ratings** are maximum limit thresholds that should **NEVER** be exceeded. These limits are established by Brinkley RV and our component manufacturers in the design of the RV.

- **Weight** and **Load** are often used interchangeably and refer to the actual weight of the RV. Weight or Load is measured by placing an RV, tow vehicle, or its components on a scale. Vehicles and added cargo add weight and affect the distribution of weight to the hitch, tires, and axles.

### **⚠ WARNING**

Exceeding a rating may result in unsafe conditions, potential damage, may void warranty, may complicate an insurance claim, and in some cases, may violate applicable law.

---

### **⚠ WARNING**

The volume of space available for storage may exceed the amount of available Cargo Capacity. Large storage compartments have been designed to accommodate normal camping items, which are bulky, but not necessarily heavy.

---

### **⚠ WARNING**

The actual total weight of the RV, its options, holding tanks and contents, personal cargo, and hitch weight are important to know so that you **DO NOT** exceed the Gross Vehicle Weight Rating (GVWR) of the RV.

---

To better understand how to safely manage your RV's weight and balance, please see the weight-related definitions outlined below:

#### **Gross Axle Weight Rating (GAWR)**

Gross Axle Weight Rating (GAWR) is the maximum weight the axles are designed to carry.

#### **Gross Vehicle Weight Rating (GVWR)**

Gross Vehicle Weight Rating (GVWR) (also known as Maximum Load Capacity) equals the GAWR plus the hitch weight. GVWR is the maximum allowed weight your trailer is rated to carry. This weight includes the weight of the trailer itself and ANY cargo or equipment you intend to haul inside the RV.

#### **Gross Vehicle/Trailer Weight (GVW or GW)**

Gross Vehicle Weight (GVW) is the actual weight of the RV, including everything in or on the RV, and is established by measuring on a scale. This is the actual weight of the trailer fully loaded.

#### **Gross Combined Weight Rating (GCWR)**

The Gross Combined Weight Rating (GCWR) is the maximum allowable weight of a fully loaded tow vehicle and the weight of the fully loaded RV combined.

#### **Gross Combined Weight (GCW)**

Gross Combined Weight (GCW) is the actual weight of your fully loaded RV and tow vehicle combined, as measured on a scale.

#### **Unloaded Vehicle Weight (UVW) (or Dry Weight)**

Unloaded Vehicle Weight (UVW) or Dry Weight is the weight of the RV as it is built from the factory with no added water, fuel, propane, supplies, or passengers. This includes only the items installed at the factory and no aftermarket installations made by you, the Dealer, or any other entity.

#### **Hitch Weight (HW) (or Tongue Weight)**

Hitch Weight (HW) or Tongue Weight is the actual amount of weight that presses down on the hitch when the RV is connected to the towing vehicle.



### Cargo Carrying Capacity (CCC)

Cargo Carrying Capacity (CCC) is the maximum weight of personal cargo that can be added to the RV.

- **In the United States:** CCC = GVWR – [UVW and LP gas weight]. Water is a component of the CCC.
- **In Canada:** CCC = GVWR – [UVW, LP gas weight, and full fresh (or potable) water weight (including the water heater)]. Water weight is not a component of the CCC.

### 2. Weight Labels

Vehicle weight labels are placed on every RV to ensure the owner and/or potential buyer is fully aware of this information. Proper weights and limitations are important to the use of your RV.

#### + NOTICE

Do not remove these labels. If the labels are missing or damaged contact your Dealer or Brinkley RV Customer Care for replacement decals.

### 3. Federal Certification Label

The Federal Certification Label specifies the maximum capacities for GVWR, GAWR, and the tires. This is located on the driver's side (also known as the off door side) towards the front of your RV. Typically, this label is located in front of the LP compartment.

Below is an example of the Federal Certification Label. Note that the information on your specific RV on this tag will vary from what is shown below:

MANUFACTURED BY/FABRIQUE PAR: Brinkley RV DATE: 10/2022  
 GVWR / PNBV 6348 KG (13995 LB)  
 GAWR (EACH AXLE) / PNBE (CHAQUE ESSIEU) 3175 KG (7000 LB)  
 UVW 5330 KG (11750 LB)  
 TIRE/PNEU ST215/75R17.5 RIM/JANTE 17.5  
 COLD INFL. PRESS/PRESS. DE GONFL. A FROID 221 KPA (125 PSI/LPC) SINGLE  
THIS VEHICLE CONFORMS TO ALL APPLICABLE U.S. FEDERAL MOTOR VEHICLE SAFETY STANDARDS IN EFFECT ON THE DATE OF MANUFACTURE SHOWN ABOVE. THIS VEHICLE CONFORMS TO ALL APPLICABLE STANDARDS PRESCRIBED UNDER THE CANADIAN MOTOR VEHICLE SAFETY REGULATIONS IN EFFECT ON THE DATE OF THE MANUFACTURE. - CE VEHICULE EST CONFORME A TOUTES LES NORMES QUI LUI SONT APPLICABLES EN VERTU DU REGLEMENT SUR LA SECURITE DES VEHICULES AUTOMOBILES DU CANADA EN VIGUEUR A LA DATE DE SA FABRICATION.  
 V.I.N./N.I.V.: 7T0FZ3620PT000002 TYPE/TYPE: TRAILER TRAV/REM. Fifth Wheel

### 4. Tire and Loading Information Label

The Tire and Loading Information Label provides tire size information, recommended tire pressure(s), and the maximum amount of cargo that can be safely added to the RV. This label is located on the driver's side (also known as the off door side) towards the front of your RV.

Typically, this label is located in front of the LP compartment. Below is an example of what the Tire and Loading Information looks like. The information contained on this tag may vary on your RV from what is shown below.

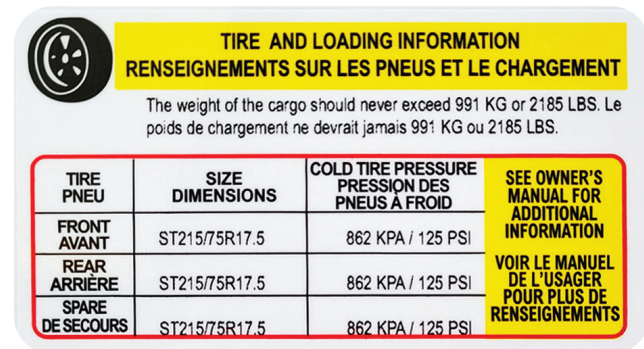

**TIRE AND LOADING INFORMATION**  
**RENSEIGNEMENTS SUR LES PNEUS ET LE CHARGEMENT**

The weight of the cargo should never exceed 991 KG or 2185 LBS. Le poids de chargement ne devrait jamais dépasser 991 KG ou 2185 LBS.

| TIRE PNEU        | SIZE DIMENSIONS | COLD TIRE PRESSURE PRESSION DES PNEUS A FROID | SEE OWNER'S MANUAL FOR ADDITIONAL INFORMATION          |
|------------------|-----------------|---|--|
| FRONT AVANT      | ST215/75R17.5   | 862 KPA / 125 PSI                             | VOIR LE MANUEL DE L'USAGER POUR PLUS DE RENSEIGNEMENTS |
| REAR ARRIERE     | ST215/75R17.5   | 862 KPA / 125 PSI                             |  |
| SPARE DE SECOURS | ST215/75R17.5   | 862 KPA / 125 PSI                             |  |

### 5. Cargo Carrying Capacity (CCC) Label

The Cargo Carrying Capacity Label specifies the maximum cargo carrying capacity for your RV. It is located on the outside of your RV on the edge of the main entry door.

An example label is provided below:

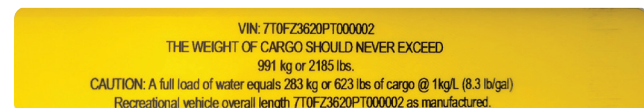

VIN: 7T0FZ3620PT000002  
 THE WEIGHT OF CARGO SHOULD NEVER EXCEED  
 991 kg or 2185 lbs.  
 CAUTION: A full load of water equals 283 kg or 623 lbs of cargo @ 1kg/L (8.3 lb/gal)  
 Recreational vehicle overall length 7T0FZ3620PT000002 as manufactured.

## 6. RV Length

### a. Travel Trailers

The length of the RV is measured from the tip of the hitch coupler to the end of the rear most extremity of the RV.

### b. Fifth Wheel Trailers

The length of the RV is measured from the most extreme front profile, commonly the tip of the pin box, to the end of the rear most extremity of the RV.

### c. RV Overall Length Exclusions

The overall length of your RV excludes select accessories as defined by Brinkley RV, including but not limited to the following:

- Safety-related equipment such as signals, clearing, indication, and warning lights.
- Appliance vent and vent hoods.
- Door latches and hinges.
- Entry and exit handles, grab bars, and/or railings.
- Exterior installed ladders.
- Spare tires, tire brackets, and/or carriers.
- Rear bumper.
- Outdoor cooking appliances.
- Towing hitch or cargo accessory receivers.
- Equipment or racks utilized to secure cargo.

## D. CARGO CAPACITIES AND WEIGHTS

When loading your RV with cargo,

**DO NOT** exceed any of the following:

- The maximum Cargo Carrying Capacity (CCC) noted on the Federal Tag.
- The Gross Vehicle Weight Rating (GVWR).
- The Maximum Load Rating of your RV tires.

## ⚠ WARNING

The load capacity of your RV is designated by weight, not by volume. All available storage space cannot necessarily be used when loading the RV. For the best possible handling:

- **DO NOT** exceed your GVWR.
- Ensure you are loading the vehicle evenly.
- Secure all loose or heavy items to prevent shifting during travel.

### 1. Maximum Load Rating

The Maximum Load Rating of your RV tires may be less than the GVWR. To calculate the load on your RV tires, subtract the hitch weight from the RV's Gross Weight or Total Weight. The hitch weight is carried by your tow vehicle, NOT the RV tires. Therefore, the hitch weight is subtracted.

#### EXAMPLE CALCULATION:

- Each RV tire is rated at 4,800 lbs. (2,177 kg), and there are 4 tires.  $4 \text{ tires} \times 4,800 \text{ lbs.} = 19,200 \text{ lbs.} (8,709 \text{ kg})$
- The Gross Vehicle Weight of the RV is 15,000 lbs. (6804 kg) with a hitch weight of 1,300 lbs. (590 kg):  $15,000 \text{ lbs.} (6804 \text{ kg}) - 1,300 \text{ lbs.} (590 \text{ kg}) = 13,700 \text{ lbs.} (6,214 \text{ kg})$  to be carried by the tires.
- In this example, the load distributed on the RV tires is 13,700 lbs. (6,214 kg) This is below the 19,200 lb. (8,709 kg) maximum tire load rating in the example.
- This figure should **ALWAYS** be under the maximum load rating of the tires. If it is not, you must remove weight from the RV to reduce the load on the tires below the maximum tire load rating.

## 2. Water and Propane (US ONLY)

- Fresh water is to be calculated as part of the Cargo Carrying Capacity Weight.
  - Water weighs approximately 8.3 lbs. per gallon (1.0 kg per liter).
  - Based on this weight per gallon, a 50-gallon (189.3 liters) tank full of water will weigh roughly 417 lbs. (189.2 kg).

When nearing GVWR, try reducing the amount of water in the holding tank to lessen the water weight and to increase the amount of weight available for additional cargo needs. This will provide additional flexibility when making choices to match your travel and camping needs without compromising safety.

### ALWAYS REMEMBER:

- The Unloaded Vehicle Weight (UVW) is calculated with empty LP bottles, holding tanks, and as built at the factory. Modifications are not included in the calculation.
- In the United States, Cargo Carrying Capacity is calculated including the weight of full LP bottles.  $CCC = GVWR - (UVW + LP \text{ gas weight})$ . Water is considered part of the cargo weight.
- In Canada, Cargo Carrying Capacity is calculated including the weight of full LP bottles and full freshwater tanks, including the water heater.  $CCC = GVWR - [UVW + LP \text{ gas Weight} + \text{full fresh/potable water tanks (including the water heater)}]$ .

For further questions, please contact your Dealer or Brinkley RV Customer Care.

## 3. Loading Your RV

When loading your trailer, it is critical that you understand the weight limitations of your RV and tow vehicle as well as the importance of maintaining a balanced load from side-to-side of the RV. [Section 5D\(4\)](#) below covers the weighing process in detail to help ensure that you properly load your RV prior to travel.

### ⚠ WARNING

**ONLY store items in the areas designated for storage. DO NOT store anything in the areas reserved for the furnace, water heater, converter, electrical panels, and other appliances.**

### ⚠ WARNING

**During a sudden stop, free-standing furniture or overlooked items on the counter tops or shelves can become dangerous projectiles. It is important to secure the appliance or furniture with tie-down straps (If Equipped or Customer Supplied). Be sure to store and secure all loose items inside your RV. Check that all items are safely put away BEFORE travel.**

## 4. Weighing the Tow Vehicle and RV

### a. In General

**Total weight** and **balance** of the RV are the two most important factors when loading your RV. It is important to **ALWAYS** follow and never exceed the weight rating limits specified for your RV. To ensure you are not exceeding your Gross Vehicle Weight Rating (GVWR) and other weight limitations, you should weigh your RV at a public scale or weigh station once your RV is fully loaded.

## SEC.05 PRE-TRAVEL INFORMATION

Utilizing a scale will also help to determine proper load distribution. To better ensure you are balancing load within your RV, it is best to use a weigh station that has separate scales to weigh the driver and passenger sides of the RV.

### + NOTICE

Individual scales and weigh stations may operate differently. If you have any questions or concerns, do not hesitate to contact us. It is our priority to ensure you have the tools necessary to safely tow your RV.

### b. Weighing Your Tow Vehicle and RV

It is important to read and understand the weighing instructions prior to attempting to weigh your RV. Understanding this information is vital to ensure your safety. When weighing your RV, it must be weighed fully loaded with all contents you intend to travel with (i.e., food, water, clothing, supplies, propane, fuel, etc.) to obtain an accurate measurement and to determine whether you are within the weight limitations provided.

### ⚠ WARNING

An RV that is overloaded or has an imbalanced load will adversely affect your tow vehicle's handling and braking capabilities. It can also lead to component failures that could leave you stranded on the side of the road. Overloading can affect your safety and the safety of those around you. It will also lead to voiding of any applicable warranties as overloading is considered a form of misuse.

### ⚠ WARNING

#### DO NOT EXCEED YOUR GVWR!

You should weigh the RV as loaded for your normal travel to determine the actual weight. If you exceed the GVWR, you **MUST** remove items from the RV, or drain liquids, then reweigh the RV to ensure you have achieved a safe weight below the stated GVWR. Also, **DO NOT** travel with full gray/black holding tanks as doing so negatively impacts fuel efficiencies and the towing and handling characteristics. It is also recommended that you **NOT** travel with a full fresh tank. You should plan to fill the fresh tank as close to your end destination as possible.

### ⚠ WARNING

**NEVER** load the RV more than the **GAWR** for either axle. Overloading the RV may result in adverse handling characteristics and damage to the RV chassis. Evenly distribute your cargo side-to-side for safe travel. The weight on each tire must not exceed one-half of the **GAWR** (Gross Axle Weight Rating) for either axle.

### ⚠ WARNING

Exceeding the established weight ratings for the axles, running gear, tires and wheels can lead to failure that can affect motor vehicle safety and lead to property damage or damage to the RV.

## PROPER WEIGHING PROCEDURE:

### 1. GROSS VEHICLE WEIGHT CALCULATION

#### Weigh your RV while unhitched

from the tow vehicle to obtain your Gross Vehicle Weight (GVW). Be sure to pull the tow vehicle far enough away such that it is not included in the weight calculation. You will also have to lower the landing gear (fifth wheel) or tongue jack (travel trailer) to obtain the weight measurement.

- a. For safe operation, your Brinkley RV's Gross Vehicle Weight (GVW) **MUST** be less than or equal to the Gross Vehicle Weight Rating (GVWR).
- b. If your Brinkley RV's GVW is greater than the GVWR, you **MUST** remove contents until the GVW is less than your Brinkley RV's listed weight ratings.

### 2. GROSS COMBINED WEIGHT CALCULATION

#### Hitch your RV to the tow vehicle.

Weigh the RV and tow vehicle to obtain your Gross Combined Weight (GCW).

- a. Confirm that your **GCW is less than, or equal to the GCWR** specified by the manufacturer of your tow vehicle.
- b. If your **GCW is greater than the GCWR**, remove contents until the weight is less than the GCWR.

### 3. HITCH WEIGHT CALCULATION

While still hitched to the tow vehicle, pull onto the scale to weigh only the RV, and record that weight. This measures the total load carried by the RV tires. This weight, when subtracted from the GVW, is your Hitch Weight.

### 4. BALANCED WEIGHT CALCULATIONS

To obtain the side-to-side weights of the RV, there must be ample room on either side of the scale to accommodate the RV being partially off the scale.

- a. Pull the RV so that the tires of only one side of the RV are on the scale. Your RV must remain as level as possible in order to obtain an accurate weight measurement.
- b. **For a balanced load:** The weight of one side of your RV, must be equal to one half (1/2) of the total weight on the tires that you measured in step 3 above. If this is not the case, then you must redistribute the load until the RV is equally balanced side-to-side.

If you have questions or concerns, please consult with your Dealer, scale operator, or Brinkley Customer Care for additional assistance.

#### **⚠ WARNING**

The total weight of your tow vehicle and RV must not exceed the GCWR. **NEVER** assume that you can tow an RV that happens to be within the capacity of the tow vehicle hitch. By doing so, you may exceed the total GCWR.

#### **⚠ WARNING**

It is important to redistribute the load to avoid component failure as well as to improve the handling characteristics of the vehicle. When a load is unbalanced, the components located on the heavier side of the RV (the wheels, brakes, springs, axle hangers, tires, etc.) may be overloaded, even though the total axle load is within the limits imposed by the GAWR.



## E. TIRE SAFETY INFORMATION

### 1. Introduction

This section of the Owner's Manual contains tire safety information as required by 49 CFR 575.6(4) and is based in part on the National Highway Traffic Safety Administration's (NHTSA) brochure entitled "Tire Safety, Everything Rides On It." This brochure is available as a free download on the NHTSA website:

<https://one.nhtsa.gov/Vehicle-Safety/Tires/Tire-Safety-Everything-Rides-On-It>.

**Tire safety studies show that the most important things you can do to avoid tire failure, blowouts and flat tires are as follows:**

- **ALWAYS** maintain proper tire pressures.
- **OBSERVE** and adhere to tire and vehicle Load Limits. **NEVER** carry more weight in your vehicle than your tires or vehicle can safely handle.
- **AVOID** road hazards.
- **DRIVE** within the designated tire speed ratings.
- **INSPECT** tires for slashes, cuts, marks, and other irregularities.

**These actions, along with other care and maintenance activities, can also:**

- Improve vehicle handling.
- Improve stopping distance.
- Increase traction.
- Improve overall fuel economy.
- Help protect you and others from avoidable and/or preventable breakdowns and accidents.
- Increase the life of your tires.

Make tire safety a regular part of your vehicle maintenance routine. Know that the time you spend on tire safety and maintenance is minimal compared to the inconvenience and safety consequences of a flat tire or other tire failure.

### 2. Maximum Load Rating

The Maximum Load Rating indicates the maximum load in pounds (or kilograms) that can be safely carried by the tire.

### 3. Maximum Inflation Pressure

The Maximum Permissible Inflation Pressure is the greatest amount of air pressure that the tire should ever be inflated to under normal driving conditions.

### 4. Recommended Tire Pressure and Load Limits

#### **WARNING**

**Under-inflated tires and overloaded vehicles are major causes of tire failure.**

Tire information placards and vehicle certification labels provide important information regarding tires, weights, and load limits, including the following:

- The recommended tire size.
- The recommended tire inflation pressure.
- The Cargo Carrying Capacity (CCC).
- The front and rear Gross Axle Weight Ratings (GAWR).

For definitions and information regarding labels See [Section 5C](#).

### 5. Understanding Tire Pressure and Load Limits

**Load Limits** are determined by the tire size and the maximum amount of weight each tire can safely carry.

**Tire Pressure** is the amount of air pressure a tire requires to achieve proper inflation. It is measured in pounds per square inch (psi) or kilopascals (kPa). Tire pressure affects your RV's overall performance and provides the load-carrying capacity.



On the Tire and Loading Information Label, the proper tire pressure for your vehicle is listed as Cold Tire Pressure. You will find this number expressed in both psi and kPa.

### **⚠ WARNING**

**Always check tire pressure when tires are cold. Cold tire inflation pressure is defined as a tire that has not been used for three (3) or more hours or has been driven less than one mile (1.6 Kilometers) prior to the pressure measurement. Note that a hot tire may increase the tire inflation pressure by as much as six (6) psi (41.4 kPa) over a cold tire. DO NOT exceed the maximum recommended pressure.**

### **+ NOTICE**

The axle and wheel assemblies on your RV are designed and manufactured much differently than that of an automobile. The overall size, weight, and balance of your RV exposes the wheels to pressures that are unique to trailering. When turning, or cornering, the wheels and tires experience a considerable amount of stress known as “side loading.”

## **6. Checking Tire Pressure**

### **a. Frequency**

It is important to check the cold inflation pressure of your RV's tires at least monthly since:

- Most tires will lose air pressure naturally over time, particularly when the outdoor temperatures fluctuate.
- Tires can suddenly lose air after driving over a pothole, hitting road debris, or striking a curb.
- With radial tires, it is generally not possible to visually determine if a tire is under-inflated.

### **+ NOTICE**

For safety and convenience, you should always keep a Tire Pressure Gauge in your vehicle.

### **b. Maintaining Proper Tire Pressure**

#### **TIRE PRESSURE:**

1. The recommended cold inflation pressure is listed on the Tire and Loading Information label located on the exterior of your RV, on the off door side, forward of the LP compartment. You should first locate this label to ensure that you know the recommended cold inflation pressure of each tire.
2. Use a Tire Pressure Gauge (Customer Supplied), to check the tire pressure of every tire:
  - a. If the tire pressure is above the maximum inflation pressure in any of the tires, gently press on the tire valve stem release valve with the edge of your tire gauge. Slowly release air until the correct pressure is obtained.
  - b. If the tire pressure is below the recommended cold inflation pressure in any of the tires, immediately add air to any underinflated tires.
3. At a service station or otherwise utilizing an air compressor, add air to each under- inflated tire until the correct cold inflation pressure is reached.  
**DO NOT OVER-INFLATE.**
4. Re-check the RV tires with the Tire Pressure Gauge. Confirm that all tires are at the same recommended cold inflation pressure. Make any additional adjustments as needed.

### ⚠️ WARNING

If the total weight of the RV (GVW) exceeds the GVWR, the RV is overloaded. Operating your RV while exceeding the specified weight ratings increases the risk of a crash, personal injury and death. It is imperative that you remove cargo (equipment, water, personal belongings, etc.) until the total weight of the RV no longer exceeds the GVWR before operating the RV.

---

### ⚠️ WARNING

Although it is ideal to check and fill tire pressures when the tires are cold, if you discover a tire on your RV that is underinflated, even if the tires are warm, add air until the recommended cold inflation pressure is reached. The warm tire may remain slightly underinflated, but this is much safer than driving with a significantly underinflated tire. **REMEMBER** to recheck and adjust the tire pressure(s) as soon as a cold tire pressure reading can be obtained to ensure proper inflation.

---

### 7. The Effect of Overloading Your RV and Tires

Overloading your RV and/or tow vehicle's suspension system can cause spring, axle, shock, chassis damage and/or brake failures. Overloading your RV can increase stopping distances, create handling and/or steering problems or difficulties, cause irregular tire wear, blow-outs, tire failure, and/or other damage to the RV and/or tow vehicle.

And, in cases of excessive overloading, RV brakes are at risk of failing completely, particularly on steep declines when the weight of the RV applies additional stress to the brake system.

Tire overloading caused by exceeding Cargo Carrying Capacity and/or improper inflation of tires may result in abnormal flexing, wear, and tear of the tire. Abnormal tire flexing can cause an excessive amount of heat to generate within the tire. This should be avoided at all costs. Failure to do so may result in fire and/or damage to tire assembly and/or RV.

### ⚠️ DANGER

**EXCESSIVE HEAT MAY LEAD TO TIRE FAILURE. PROPER INFLATION IS CRITICAL.** It is the air pressure that enables a tire to support the load.

---

### ⚠️ DANGER

Overloading your RV can have serious consequences for passenger safety. An overloaded vehicle is generally harder to drive and more difficult to stop. Excessive overloading may also cause brakes to fail completely.

---

### ⚠️ DANGER

If the weight on the trailer axles exceeds the GAWR, the axles are overloaded. Operating your RV while exceeding the specified weight ratings increases the risk of a crash, personal injury, and death. It is imperative that you remove or rearrange cargo (equipment, personal belongings, water, etc.) until the axle weight no longer exceeds the GAWR before operating the unit. Not operating your RV within the designed weight ratings can damage your RV and can void the warranties.

---

## 8. Proper Tire Load Limits

Tire size, load range, and corresponding inflation pressure all determine the load a tire can safely carry. The required air pressure for RV tires must be determined by the actual load of the RV and taken from the Load and Inflation Tables provided on the tire manufacturer's website (See [Section 5D\(4\)](#) for weighing instructions).

- The air pressures recommended on tire manufacturing websites may differ from those provided on the certification label of your RV.
- RV weight and/or tire pressure should never exceed the tire's stated Maximum Load Rating or maximum air pressure.
- If you discover that your tires cannot support your RV's weight, REMOVE enough cargo until the RV's weight is within the stated limits.

### To determine the correct cargo load limit:

- Locate the statement "The weight of cargo should **never exceed** XXX KG or XXX LBS" on your RV's Cargo Carrying Capacity label. See [Section 5C\(5\)](#) for information on the CCC label.
- The Cargo Carrying Capacity is the available load capacity for cargo and luggage (See [Section 5](#) above for full details and definitions). The combined weight of cargo and luggage loaded on your RV must not exceed the Cargo Carrying Capacity.

## 9. Tire Safety Tips

### Preventing tire damage

- **DO NOT** run over curbs, potholes or foreign objects in roadways, campsites, or when parking.
- **SLOW WAY DOWN** if you cannot avoid a pothole, animal, or any other object in the road.

### TIRE SAFETY CHECKLIST:

1. **CHECK** all tire pressures prior to every trip, including any spare tires.
2. **INSPECT** all tires for uneven wear patterns, cracks, foreign objects, or any other damage.
3. Carefully **REMOVE** bits of glass or foreign objects wedge in the tread.
4. **CHECK** that the valve caps are on the tire valve stems.
5. **CHECK** the wheel torque prior to each trip. See [Section 5J](#).
6. **DO NOT** overload your vehicle.

### + NOTICE

FOLLOW the instructions for cargo and cold tire pressure found on your Tire and Loading Information label.

## 10. Tire Labeling

Federal law requires that tire manufacturers provide standardized information molded into the sidewall of all tires sold in the United States. This information includes:

- Tire size.
- Construction.
- Various capacities (maximum pressure, load, speed).
- Tire Identification Number.

## US DOT TIRE IDENTIFICATION NUMBER (TIN):

The Tire Identification Number is provided for safety standard certification and in the event of a recall. This identification is considered the tire's serial number and provides specific production details to the tire.

- The TIN begins with "DOT" and is usually followed by 10-12 numbers, letters, and symbols.
- The first two (2) numbers or letters following DOT, signify the plant in which the tire was manufactured.
- The last four (4) numbers signify the week and year the tire was built (i.e., 2123 = the 21st week of 2023).
- The remaining characters in the TIN are codes used at the tire manufacturer's discretion and vary by supplier.

## 11. Tire Size and Type Designation

The tire specifications are located on the Tire and Loading Information label or on the sidewall of the tire that you are replacing. As an example, the tires on your RV at the time of publication of this Owner's Manual are marked with a designation of:



## Coding Break Down

- The first three (3) digit number (215 in the example above) provides the tire width in millimeters measured from sidewall edge to sidewall edge.
- The next two (2) digit number after the "slash" mark (75 in the example above), provides the tire height-to-width ratio of the tire. This is also referred to as the aspect ratio.
- The "R" stands for radial.
- The last three (3) digit numbers (17.5 in the example above) is the diameter in inches of the wheel.
- Finally, "HRT" means that the tire is H-rated. The rating dictates the maximum speed of the tire. In this case, the maximum speed for an H rated RV tire is 75 miles per hour (mph) (120 kilometers per hour (kph)).

**DO NOT exceed the Speed Rating regardless of the posted maximum speed limit.**

For further information, please contact a tire Dealer, Brinkley RV Customer Service, or refer to the full tire sidewall diagram referred to the right:

## GET TO KNOW YOUR TIRE SIDEWALL

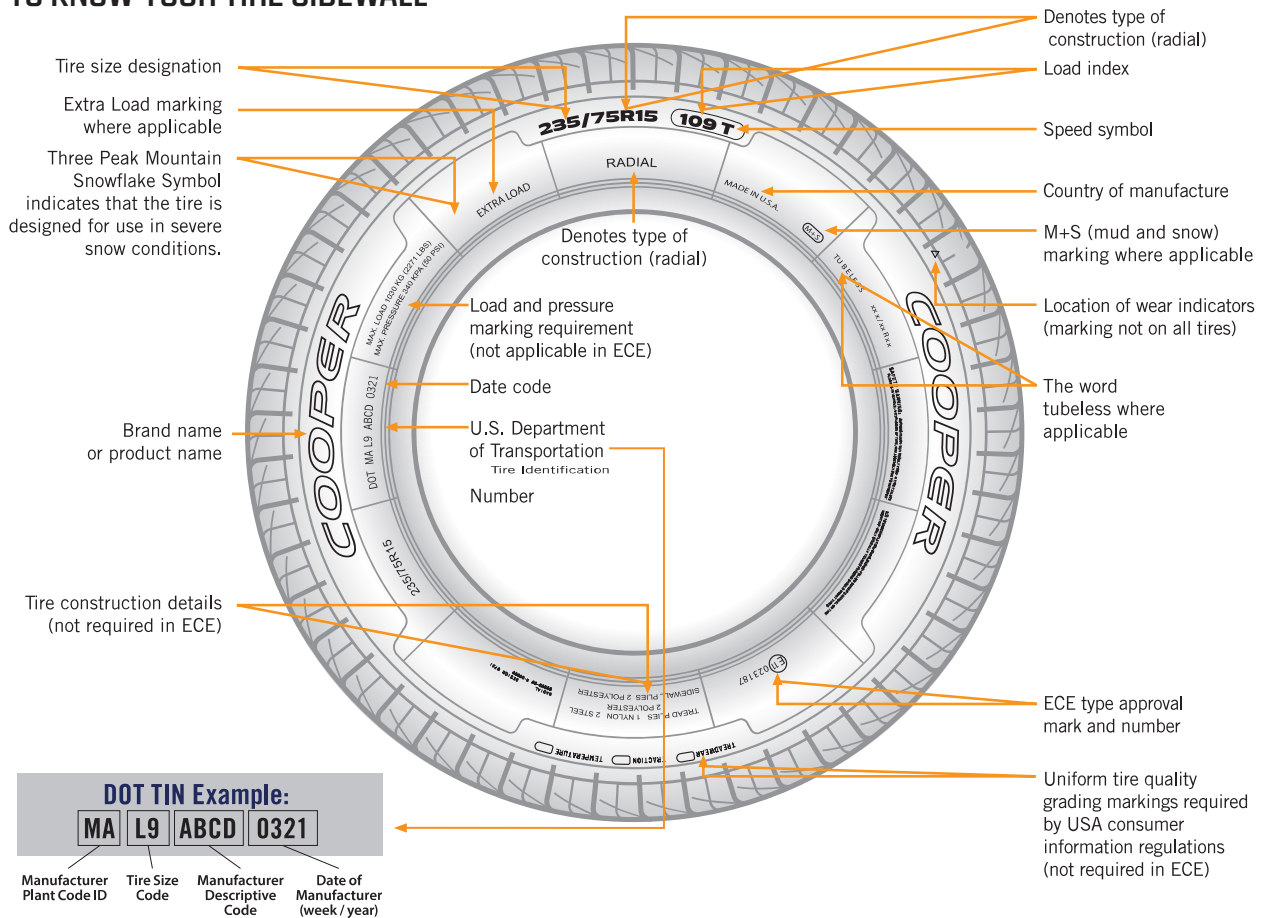

Source: Cooper Tires

## F. TIRE TREAD

The tread of the tires is what provides frictional force, water evacuation, and traction that prevents your RV and vehicle from slipping and sliding. The frictional force also assists in slowing the RV or vehicle down within acceptable stopping distances. This is particularly important when the road conditions are wet, snowy or ice covered. Tires with 1/16" or less tread depth are not safe and should be replaced.

**Tread wear beads** are raised sections built into the bottom of a tire's treads to show how much tread remains.

When your tread wear beads appear to be even with the outside of the tread, it is an indicator that it is time to replace your tires. There are also gauges utilized by service centers to measure the remaining tread depth. Please refer to the picture shown below and right for additional detail.

Inspect your tires regularly for uneven tread wear. Uneven tire wear is an indication of imbalanced loads, over or under-inflated tires, wheel balance, or other misalignments. The sooner the cause of the uneven tread wear is remedied, the better. Replacing tires can be an expensive endeavor.

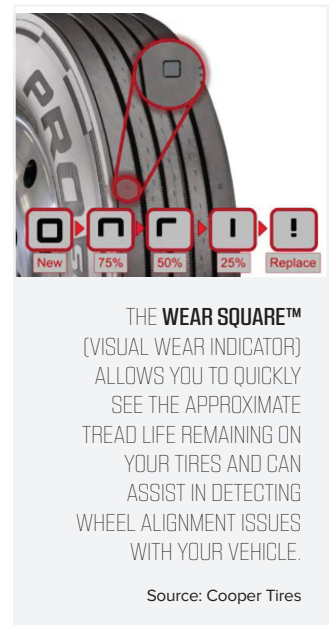

# SEC.05 PRE-TRAVEL INFORMATION

For your ease of reference, the table below shows the various forms of uneven tire wear and their likely cause:

## TIRE WEAR DIAGNOSTIC CHART

| WEAR PATTERN  | CAUSE              | ACTION                        |  |
|---|--------------------|-------------------------------|--|
|    | <b>CENTER WEAR</b> | OVER INFLATION                | ADJUST PRESSURE TO PARTICULAR LOAD PER TIRE CATALOG                  |
|    | <b>EDGE WEAR</b>   | UNDER INFLATION               | ADJUST PRESSURE TO PARTICULAR LOAD PER TIRE CATALOG                  |
|    | <b>SIDE WEAR</b>   | LOSS OF CAMBER OR OVERLOADING | MAKE SURE LOAD DOESN'T EXCEED AXLE RATING . ALIGN AT ALIGNMENT SHOP. |
|    | <b>TOE WEAR</b>    | INCORRECT TOE-IN              | ALIGN AT ALIGNMENT SHOP  |
|   | <b>CUPPING</b>     | OUT-OF-BALANCE                | CHECK BEARING ADJUSTMENTS AND BALANCE TIRES                          |
|  | <b>FLAT SPOTS</b>  | WHEEL LOCKUP & TIRE SKIDDING  | AVOID SUDDEN STOPS WHEN POSSIBLE AND ADJUST BRAKES                   |

## G. TIRE PLY COMPOSITION AND MATERIALS

Tires are constructed from multiple layers of rubber coated fabrics. Each layer is referred to as a ply. In general, the higher the number of plies in a tire, the more weight it can support.

Tire manufacturers must report all materials used in the composition of their tires, (steel, nylon, polyester, etc.). To the right is a typical picture of the anatomy of a typical Cooper radial tire.

## H. SPARE TIRE

The spare tire is utilized for instances where an RV tire is damaged, flat, or otherwise fails to maintain air pressure.





### ⚠ WARNING

The spare tire and wheel may differ from the original equipment. The spare tire is only intended for temporary use. Please refer to the tire specifications on the sidewall of the spare tire for additional information and to ensure your safety.

The spare tire is secured below your RV. Locate the 1" (2.54 cm) access hole in the skirt metal on the door-side of your RV, approximately even with the spare tire. The photo below shows the location of the 1" access hole. The second photo below shows the location of the access hole relative to the spare tire location.



- Insert the crank handle extension.
- Turn the crank handle **counterclockwise** to lower the spare tire.
- Turn the crank handle **clockwise** to raise the spare tire.

## I. TIRE CHANGING BASICS

Use a hydraulic jack and jack stands (both items Customer Supplied) when changing a tire. Below are generalized instructions on changing an RV tire.

### CHANGING THE TIRE:

1. Before beginning, block the wheels on the opposing side of the tire in need of being changed. This will prevent accidental movement while changing the tire and is vital to ensure safety.
2. Before lifting the RV with a hydraulic jack (Customer Supplied), loosen the wheel lugs on the tire.
3. Place the hydraulic jack on the I-beam of the RV frame and close to the spring hanger. Slowly lift the RV until the tire is hovering an inch (2.54 cm) or two (5.08 cm) above the ground.
4. Place a jack stand under the RV frame just behind the tire being changed. The jack stand serves as a safety measure to prevent the RV from falling if the hydraulic jack moves or fails to hold the weight of the RV.
5. Once fully stabilized, continue with changing the tire and follow the wheel nut torque specifications and wheel.

# SEC.05 PRE-TRAVEL INFORMATION

## ⚠ WARNING

**NEVER** use a stabilizer jack or the leveling system to lift the RV. The stabilizer and leveling jacks are not intended to lift the unit off the ground. Utilizing these jacks to change a tire could result in injury, property damage, voiding a warranty, or death.

## ⚠ WARNING

Before you climb or crawl underneath the RV, both the front and rear axles should be supported with jack stands. Failure to do so may result in serious injury, property damage, or death.

## J. WHEEL NUT TORQUE

The torque of the wheel lug nuts must be maintained and inspected on a continuous basis. Torque measures the tightness of a lug nut or the rotational force and is measured in foot-pounds (ft-lbs.) or Newton meters (Nm). When checking torque, please see the following instructions.

- **ALWAYS** properly calibrate the torque wrench prior to use.
- **NEVER** use a torque wrench that is worn out or damaged.
- **ALWAYS** check every lug nut's torque prior to departure. Regardless of how short the trip may be, proper lug nut torque is imperative to ensure your safety.
- **DO NOT** under or over-torque any lug nut. Under and over-torque can be dangerous and may cause damage or failure.
- **ALWAYS** tighten lug nuts with the correct lug pattern shown in the diagram below.

## Tire Installation:

Once the wheel and tire are removed, and the wheel and tire assembly are mounted, start by hand tightening all lug nuts until snug and then tighten per the torque sequence indicated in the diagram below.

- **1st Stage**—Tighten all lugs to 20-25 ft. lbs. of torque.
- **2nd Stage**—Tighten to 50% of the final torque specification.
- **3rd Stage**—Tighten to stated final torque specification.

## TORQUE SEQUENCE

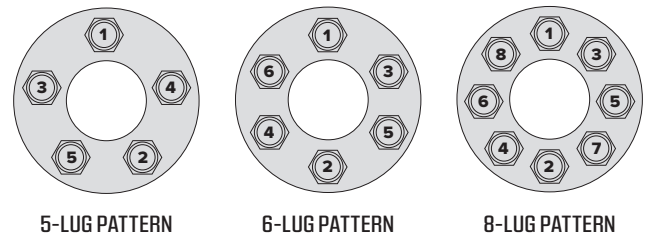

Determine the correct torque and torque sequence for each stage and use the Final Torque Specification Table shown below.

## WHEEL TORQUE SPECIFICATION TABLE

| STUD SIZE | LUG NUT TYPE | FINAL TORQUE SPECIFICATIONS       | WHEEL SIZE  | WHEEL MATERIAL |
|-----------|--------------|-----------------------------------|-------------|----------------|
| 1/2"      | CONED        | 90-120 FT. LBS. (122-162.7 NM)    | 14"/15"/16" | STEEL          |
| 9/16"     | CONED        | 120-140 FT. LBS. (162.7-189.8 NM) | 16"         | STEEL          |
| 1/2"      | CONED        | 90-100 FT. LBS. (122-135.6 NM)    | 14"/15"/16" | ALUMINUM       |
| 9/16"     | CONED        | 120-140 FT. LBS. (162.7-189.8 NM) | 16"         | ALUMINUM       |
| 9/16"     | CONED        | 140-170 FT. LBS. (162.7-230.5 NM) | 17.5"       | ALUMINUM       |

### ⚠ WARNING

Always torque the wheel lug nuts to the specifications provided by the wheel manufacturer. Over and under-torqued wheel lug nuts can cause the wheel to separate from the mounting surface during transport, causing property damage, personal injury, or death.

### + NOTICE

Lug nuts on the RV wheels require frequent torque maintenance. Torque measures the tightness of a lug nut or the rotational force and is measured foot-pounds (ft-lbs.) or Newton meters (Nm).

## K. TIRE WARRANTY

Tires are warranted by the Tire Manufacturer, not by Brinkley RV directly. If you require tire warranty assistance, please refer to the tire warranty information provided in the Owner Information Package and in Section 4 of the provided Warranty Guide. Note that you can always contact your selling Dealer or Brinkley Customer Care for further assistance.

## L. ROADSIDE EMERGENCY

A roadside emergency can occur at any given time. **ALWAYS** carry an emergency travel kit (Customer Supplied) with three red warning flags, flares, or cones to display if necessary.

### In case of an emergency roadside stop:

- Pull off the side of the road as far as possible ensuring you are away from traffic.
- Turn ON the vehicle and trailer hazard lights to alert other drivers to pass with caution.
- Place the three (3) warning indicators (flares, signs, flags, reflectors, cones, lanterns, etc.) as follows:

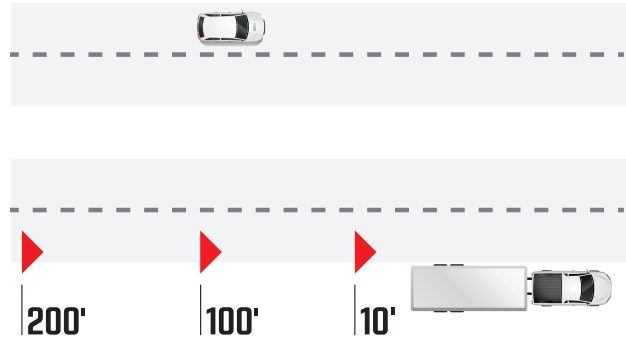

**1st indicator:** 10 feet (3.05 m) behind the RV driver's side also referred to as off door side.

**2nd indicator:** 100 feet (30.5 m) behind the RV in the center of the lane in which you are in.

**3rd indicator:** 200 feet (60.7 m) behind the RV in the center of the lane in which you are in.

- Address the emergency promptly and as cautiously as possible.

### + NOTICE

Curves and/or elevation changes in the roadway may affect the safe placement of warning indicators. Please plan to make adjustments to their placement as necessary. The purpose of the warning indicators is to provide a warning to others and for your own safety. Use common sense with this goal in mind to guide proper placement.

### + NOTICE

If roadside assistance is needed, please contact SafeRide. This roadside assistance program is provided to you free of charge for the first year of ownership. Their contact information can be found at the bottom of every page. This service is provided by Brinkley RV for the first twelve (12) months of ownership of a new Brinkley RV.

## SEC.06 TIRE PRESSURE MONITORING SYSTEM



Your RV is equipped with a Truck System Technologies® (TST) Banded Tire Pressure Monitoring System (TPMS). These banded sensors are mounted on the wheel at the factory and are located 180 degrees from the valve stem.

The purpose of a tire pressure monitoring system (TPMS) is to warn you of any issues that may create unsafe driving conditions. These conditions may include overinflation, underinflation, or overheating of the tire(s). TST TPMS offers real time pressure and temperature readings as you are traveling with your RV. Prior to the RV leaving the factory, the TPMS sensors are programmed and the monitor is ready for use upon purchase of your RV.

### NOTE: PARAMETER SETTINGS FROM FACTORY ARE THE BELOW:

- Pressure Unit: psi (kPa)
- High Pressure Alarm: 175 psi (1206.5 kPa).
- Low Pressure Alarm: 100 psi (689.4 kPa).
- Temperature Unit: ° F (° C).
- High Temperature Alarm: 158° F (70° C).

## A. DISPLAY ALERTS

The TST TPMS monitor is capable of providing many alerts. These include the Out of Parameter Alert, High Pressure Alert, Low Pressure Alert, High Temperature Alert, Low Temperature Alert, Fast Leak Alert, and Sensor Low Battery Alert.

### 1. Out of Parameter Alert

The sensors send the tire pressure and temperature readings to the display every five (5) minutes. If a tire is outside of the parameters that were set at any time, the audible alarm will sound and the red LED light will immediately flash. The tire in question, pressure or temperature for that tire, and warning type will also flash. The audible alarm can be silenced for a short period by pressing any of the buttons on the front of the display. The red warning light will continue to flash until the pressure or temperature issue is resolved and brought back into your preset parameters.

### 2. High Pressure Alert

Example: High pressure threshold is 175 psi (1206.5 kPa).

1.  & **HI PRESSURE** is displayed.
2. The tire pressure is too high.
3. Deflate the tire to the normal pressure.



### 3. Low Pressure Alert

Example: Low pressure threshold is 100 psi (689.4 kPa).

1.  & **LO PRESSURE** is displayed.
2. The tire pressure is too low.
3. Inflate the tire to the normal pressure.



### 4. High Temperature Alert

Example: High temperature threshold is 158° F (70° C).

1.  & **HI TEMP** is displayed.
2. The tire temperature is too high.
3. Pull over to a safe location and assess the cause of the high temperature alert. If your tire pressure is low, this could be the cause.





# SEC.06 TIRE PRESSURE MONITORING SYSTEM



## 5. Fast Leak Alert

When a fast tire leak is detected (loss of 2 psi (13.78 kPa)) or more in less than one minute), the sensor will send that data immediately to the display, the audible alarm will sound and the red LED light will immediately flash. The affected tire, pressure and temperature for that tire, and **FAST LEAK** will also flash.

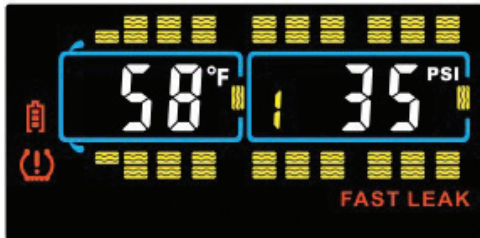
The audible alarm can be silenced for a short while by pressing any of the buttons on the front of the display. The red warning light will continue to flash until the pressure or temperature issue is resolved and brought back into your preset parameters.



## 6. Sensor Low Battery Alert

The sensor low battery indicator will display when the sensor battery is low. The affected tire will flash along with the pressure and temperature read-out and the  and  symbols on the left side of the display. Replace with a new battery as soon as possible.

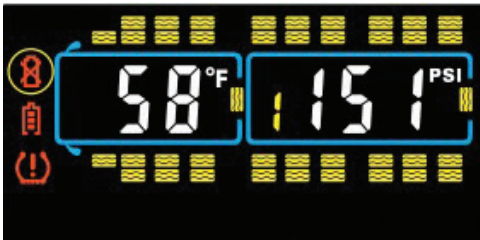

## + NOTICE

This low battery alert will display for only a short time until the battery is exhausted. If you do not have the display on often, the indicator signal will be sent but not show on the display, since the display was off. If your sensor is not reporting to the display, replace the battery.

## B. COMMON FUNCTIONS

### 1. Normal Display Scrolling

The tire icons on the display will automatically scroll/cycle through, one by one. Each tire will be displayed for approximately 5-6 seconds. You can manually cycle through the displayed tires by pressing “-” or “+”. The display will show the tire you choose for approximately 10 seconds before continuing to cycle.

### 2. Back-Lighting and Motion Detection

The display is equipped with a light sensor and a motion sensor. The backlight will turn on when the vehicle is in motion and there is little ambient light. If the vehicle has stopped for a while and the display is on the internal battery, the display will “go to sleep” until the vehicle resumes motion.

### 3. Disconnecting and Reconnecting a Vehicle

When a trailer is displayed on the screen and you want to temporarily remove it (example: leaving a trailer at a campground), momentarily press **GO** and “-”, the trailer section of the display will disappear, the sensors on the trailer will not be read. To add the trailer back onto the display, again, momentarily press **GO** and “-” and the towed vehicle will reappear.



When a towing vehicle is displayed on the screen and you want to temporarily remove it (example: leaving a truck or car at a campground and using another vehicle to move the RV), momentarily press **GO** and “+” and the truck (towing) section of the display will disappear, the sensors on the towing vehicle will not be read. To add the truck (towing) section back onto the display, again, momentarily press **GO** and “+” and the towing vehicle will reappear.

#### 4. Trailer Selection

Four different trailers with sensors can be programmed into the display and each trailer can be selected to be viewed on the screen and designated by numbers 1 to 4. On the Main Screen, press the **GO** button to select different trailers and trailer wheel groups you have programmed sensors to.

Note that when in the High or Low Pressure areas, press **GO** to move through the four main axles, the front spare tire, the trailer 1 front-3 axle group, the trailer 1-rear axle group and spare, then to trailer 2, 3 and 4 with the same pattern. After trailer 4, the front steer axles will again highlight. Each flashing tire group on the trailer can have its own High or Low Pressure setting. If setting up one trailer or towed vehicle, be sure #1 is showing for all tires programmed to that trailer.

#### 5. Charging the Display

The display is powered by a non-replaceable, lithium-ion battery. A battery level indicator is located on the left side of the display. When the indicator shows one bar, it is recommended you charge the display as soon as possible to avoid disruption when in use. It will take approximately four (4) hours to fully charge. Do not keep a fully charged display plugged in constantly.

For troubleshooting, reprogramming, or other miscellaneous information on your TST TPMS, please refer to the manufacturer’s manual provided in the Owner’s Information Package.

#### **WARNING**

**If a roadside emergency occurs, ALWAYS stand off the roadway and away from traffic. This is for your personal safety. Failure to do so may result in personal injury or death.**

---

## SEC.07 TOWING & LEVELING

### A. RECOMMENDED SAFETY

To improve safety and to help protect against injury, follow the below recommendations:

- **ALWAYS** keep tires properly inflated and replace worn tires as needed on the RV and tow vehicle. Do not wait until they are excessively worn.
- **ALWAYS** obey all traffic laws and wear your seatbelt.
- **DO NOT** exceed the posted roadway speed limit.
- Follow lowered speed limits for tow vehicle and RV combinations.
- **ALWAYS** be alert and considerate while driving.
  - Be observant of other drivers, motorcyclists, bicyclists, and pedestrians.
  - Be vigilant to possible traffic and road conditions.
  - Prior to merging or changing lanes, check all mirrors for other vehicles, use a turn signal, and merge with caution.
  - Account for sudden braking and other possible unexpected events.
- **ALWAYS** operate daytime running lights on your tow vehicle to increase visibility to other drivers.
- **NEVER** drive when drowsy or tired, especially at nighttime.
- **NEVER** drive under the influence of drugs, alcohol, or medications that may impair your reflexes, alertness, or judgment.
- **ALWAYS** be aware that weather conditions and extreme terrain may affect your tow vehicle and RV performance and handling.

- **NEVER** use cruise control when roads may be wet, icy, winding, or any other traffic situations that may require rapid response and sudden reductions in speed.
- **ALWAYS** before operating a cellular device while towing your RV, be sure to know the local laws, and understand the dangers using your cellular device poses. Even if local laws permit using cellular devices while towing, you should only do so when parked, stopped at a traffic signal, or otherwise not in motion. Distracted driving can be as dangerous as driving under the influence.
- **NEVER** leave children or pets unsupervised in, or around the RV. Even children confined in child restraint systems (i.e., pack-n-plays, car seats, walkers, bouncers, swings, etc.) should be supervised to ensure safety.

#### Propane Safety

- **ALWAYS** shut off ALL propane appliances and turn off and secure LP tanks PRIOR to traveling. If driving with the LP system on or open, the level of danger will increase substantially in the event of a fire or accident.

#### WARNING

Utilizing a cellular device while driving, puts you and all other passengers at greater risk of accidents, injury, or even death. Distracted driving can be as or more dangerous than driving while intoxicated.

---

#### WARNING

Children and pets should be supervised at all times to ensure their safety remains your number one priority.

---

## B. RV DRIVING SCHOOLS AND SEMINARS

If you have any concerns about towing your RV, consult an expert for tow driving education. There are many RV owner organizations and training facilities that offer tow driving classes and seminars. Brinkley RV is not affiliated with any of these locations or services. To obtain additional information and schedules you must contact the provider directly. Many can be found online, through RV publications, or at various RV campgrounds.

Be cautious when using websites and social media as a research tool. Always verify the information through various sites and always try to use accredited, reliable sources in the RV industry. Always make sure the information you are researching pertains to RV's. If you have any doubts or additional concerns, contact your Dealer or Brinkley RV Customer Care for assistance.

## C. RV BRAKING SYSTEM

### 1. General

To maintain proper use and performance of your RV brakes, they must be used in combination with the brakes of your towing vehicle. RV brakes are designed to work alongside the brakes of your towing vehicle and should not be operated separately. If separately used, the brake system will experience accelerated wear, tear, and damage.

### **⚠ WARNING**

**Using only the trailer brakes can result in overheating that causes damage to the brake components and could potentially lead to a fire.**

#### Brake Control System Components:

- Brake controller (Customer Supplied).
- Wire harness and connectors.
- Towing 7-way plug.
- Auxiliary batteries (See [Section 11E\(3\)](#)).
- Breakaway switch.

### 2. Brake Controller

A brake controller (Customer Supplied) is highly recommended to assist in the performance of your brake system. It is installed in your tow vehicle and will assist in adjusting the sensitivity of the brakes. Please consult with your Dealer or the supplier of the brake controller to decide which controller is best for your RV and tow vehicle combination.

### 3. Tow Assist and ABS

Your RV may also be equipped Tow Assist system featuring Anti-Lock Braking (ABS), Sway Mitigation, and Towable Odometer. Tow assist helps create a safer towing experience for all skill levels, assisting with evasive maneuvers and avoiding critical towing errors.

#### a. Anti-Lock Braking System (ABS)

This feature helps regulate the brake levels. This is done to increase road traction and to reduce the probability of tire skid, lockup, and/or jack-knifing. ABS also ensures the braking at each wheel remains constant and consistent at all times when operating as a unit.

#### b. Sway Mitigation

This feature stabilizes the trailer at speeds over 40 MPH (64.4 KMH) by responding to irregular movement and unbalanced load. This is achieved by the system intuitively applying brakes when needed.

#### c. Towable Odometer

This feature provides diagnostic code information, mileage, and unit VIN information.

For more information, please see the manufacturer's manual or follow the below QR.



## SEC.07 TOWING & LEVELING

### D. 7-WAY HARNESS TOWING CONNECTOR PLUG

The 7-way wire harness, also known as the towing connector plug, is a wire harness that, when connected from the tow vehicle to the RV, will supply limited power to the RV. This limited power source is supplied to the RV brakes, clearance lights, running lights, turn signals, brake lights, etc. It also functions as a means of trickle charging the RV battery(ies).

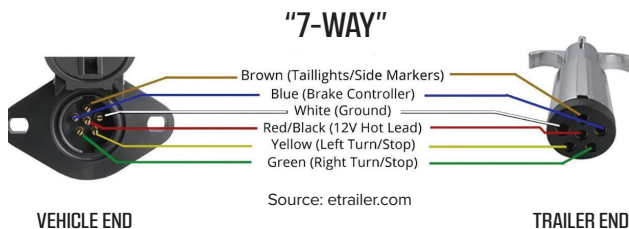

#### Maintenance

Due to weather and environmental elements, corrosion may form on the 7-way connector.

**CLEAN** the connector plug before every use to ensure proper electrical contact. **INSPECT** the connector plug frequently to ensure no damage or additional wear has compromised the housing on the plug that may further expose the wires to the elements as you travel. **REPLACE** if cracked, broken, or damaged.

#### **⚠ WARNING**

**If the towing connector plug is damaged, you must replace it immediately. A failure to replace the towing connector plug when damaged may result in an electrical short leading to accidents, damage, fire, injury, and/or death. The connector plug provides all safety related lighting as well as power to your RV brakes.**

### E. BREAKAWAY SWITCH

On every RV, a breakaway switch is installed to ensure that if the RV becomes disconnected from the tow vehicle, the RV brakes will engage. Depending on your RV type, the breakaway switch is located on the pin box (fifth wheel) or A-frame (travel trailer) of the RV. The breakaway switch is a crucial part of the RV braking system and should NEVER be removed.

If the RV becomes disconnected from the tow vehicle, the cable from the breakaway pulls the pin from the switch and engages the RV brakes.



- **ALWAYS** secure the breakaway switch cable to a permanent location on the tow vehicle when hitching the RV.
- **ALWAYS** ensure the auxiliary battery (If Equipped or Customer Supplied) is correctly installed and is fully charged PRIOR to departing.



### ⚠️ WARNING

The breakaway switch will only operate when it is supplied with power from an auxiliary battery (Customer Supplied or If Equipped). If you fail to install an auxiliary battery, there will not be power at the breakaway. This could lead to a catastrophic accident resulting in damage, injury, and/or death.

### ⚠️ WARNING

NEVER utilize the RV's brakes or breakaway switch as a parking brake. When the RV brakes are engaged, they are energized and draw power from the converter and auxiliary battery (Customer Supplied). This form of misuse can lead to damage to the brakes, wiring, connectors, and breakaway switch and/or could lead to a fire.

### ⚠️ WARNING

Always ensure that the breakaway switch cable is long enough to accommodate making tight turns. Failing to ensure the cable is long enough may result in the breakaway pin being pulled and engaging the RV Brakes. Such an occurrence may lead to significant damage or could cause a fire.

### + NOTICE

Your RV is provided with a Safety Break-Away Switch label. Do not remove or cover this label. If it is damaged, covered, or missing, it should be replaced immediately. The label should look similar to the following example:

**SAFETY BREAK-AWAY  
SWITCH WILL NOT OPERATE**  
 unless connected to a power source  
 equivalent to or greater than an automotive  
 type 12 volt, 12 amp hour wet-cell battery

## F. FIFTH WHEEL PIN BOX HITCH

### 1. General Information

Your RV is equipped with a Gen-Y pin box that utilizes the Lippert Rhino mounting bolt pattern. Please see the provided photo below.



There are many hitch assemblies available in the marketplace that vary in their specifications and use.

Hitch selection directly impacts towing and handling of your RV. Careful consideration is crucial when considering a pin box modification, upgrade, and/or replacement.

How each hitch type affects towing and handling should be considered if you are looking to purchase an aftermarket pin box. Make sure the proper hitch is selected for your specific RV and towing vehicle. Once that selection has been made, make sure your hitch is properly installed for a safe towing experience.

## SEC.07 TOWING & LEVELING

A fifth wheel requires a pin box hitch (Customer Supplied) bolted directly to the floor of the truck box through the frame. Please contact your Dealer for the proper class and type of hitch you need to purchase for your individual tow vehicle and RV combination.

### + NOTICE

At the time of publication of this manual, the Brinkley RV Model G utilized a Gen-Y pin box with the Lippert Rhino mounting bolt pattern. From time to time, without notice, Brinkley RV may make changes to improve its products. As such, it is important for you to identify and verify the correct pin box type supplied with your RV and ensure that any aftermarket replacements are both compatible and authorized for use with your RV.

### ⚠ WARNING

The pin box that is provided at the time of purchase of your RV is specifically designed to work with your RV. It is critical that, if you decide to replace or upgrade your pin box, that you select a version that is compatible with and approved for use with your particular RV. Utilizing a pin box that is not designed for your particular RV application may result in catastrophic damage, injury and/or death. Further, utilization of an incompatible or unapproved pin box may void your warranty.

### 2. Gooseneck Pin Box

Lippert has multiple gooseneck pin boxes that are compatible with the frame utilized on your RV. If you wish to change to a gooseneck on your RV, it is highly recommended you contact your Dealer or Lippert directly for recommendation and assistance.

### ⚠ WARNING

**Utilization of other gooseneck hitches may result in damage to the chassis, particularly the upper deck and sidewalls.**

### + NOTICE

Utilization of unapproved pin boxes may void your chassis warranty from Lippert and your Brinkley RV supplied warranties if the pin box you utilize actually cause the damage to the chassis or RV.

### 3. Fifth Wheel Pin Box Height

Many fifth wheel pin boxes are adjustable to accommodate for the height variance in trucks and suspension systems. There is no recommended hitch height for fifth wheels but your hitch assembly should be adjusted so that your tow vehicle and RV are level.

- **When the hitch is adjusted too high**, the weight of the RV will shift to the rear of the RV, behind the axles and may cause the tow vehicle to fishtail as a result.
- **When the hitch is too low**, the weight will transfer forward and apply additional weight to the hitch. This, in turn, may affect handling and steering of the tow vehicle.

To adjust the hitch to the proper height, please refer to the hitch manufacturer's instructions.



#### 4. STANDARD PIN BOX HITCHING

##### TO SAFELY HITCH YOUR FIFTH WHEEL TO THE TOW VEHICLE, USE THE FOLLOWING STEPS:

1. **PARK** on a level surface. Ensuring your tow vehicle and RV are parked on a level and sturdy surface will ensure a solid kingpin connection and make it easier to back your tow vehicle up to the RV.
2. **ALWAYS** use wheel chocks on both rear RV tires to prevent the RV from moving.
3. **ENSURE** the fifth wheel jaws (hitch lever) are in the **OPEN**, or cocked, position (unless it opens automatically by design).
4. **OPEN** the tailgate (If Equipped) of the tow vehicle.
5. **BACK UP** the tow vehicle until the hitch is approximately 4" (10.16 cm) from the kingpin. Then, stop the tow vehicle and place it in park.
6. **ADJUST** the fifth wheel pin to the necessary height by adjusting the front RV jacks (landing gear legs) up or down as necessary. The plate on the front bottom of the pin box should be approximately ½" (1.27 cm) lower than the top of the 5th wheel hitch. You are now ready to hitch.
7. **BACK UP** the tow vehicle slowly until the kingpin is fully seated within the hitch. Gentle contact of the hitch saddle against the pin will cause the receiver to close. It is critical to inspect the connection to ensure proper engagement.
8. **SECURE** the hitch lever as specified by the manufacturer and install the provided safety pin into the handle.

9. **TEST** the connection. Place the tow vehicle into drive and slowly let off the brake pedal to allow the tow vehicle to lightly tug at the RV. If resistance is felt, the hitch connection is secure. If not, you will need to restart the process starting at step 1 above.
10. **CHECK** that the RV landing gear legs (front jacks) are fully **RETRACTED**.
11. **ATTACH** the breakaway switch cable to the tow vehicle. Leave enough slack to accommodate tight turns.
12. **CONNECT** the 7-way wire harness from the RV to your tow vehicle and secure in the travel position.
13. **WALK AROUND** the RV to verify the exterior lights are all working correctly.
14. **REMOVE** the wheel chocks from the trailer wheels.
15. You are now ready to tow the RV.

#### **WARNING**

**NEVER** climb under the RV while it is being towed, lifted, or leveled.

#### **WARNING**

**Failing to follow the above-described hitching steps may lead to property damage, injury and/or death. Further, failing to retract the front jack(s) can lead to substantial damage to the jacks, your tow vehicle, and/or the RV.**

### 5. GOOSENECK PIN BOX HITCHING

#### TO SAFELY HITCH YOUR FIFTH WHEEL TO THE TOW VEHICLE, USE THE FOLLOWING STEPS:

1. Follow steps one through four found under the standard pin box hitching instructions.
2. **BACK UP** the tow vehicle until the hitch directly aligns with the coupler. Then, stop the tow vehicle and place it in park.
3. **ADJUST** the fifth wheel pin to the necessary height by adjusting the front RV jacks (landing gear legs) up or down as necessary. If you have an auto latching coupler, check to ensure the coupler engages. If you do not have an auto latching coupler, you will need to manually lock the coupler.
4. **SECURE** the hitch lever as specified by the manufacturer and install the provided safety pin into the handle.
5. **TEST** the connection. Place the tow vehicle into drive and slowly let off the brake pedal to allow the tow vehicle to lightly tug at the RV. If resistance is felt, the hitch connection is secure. If not, you will need to restart the process starting at step 1 above.
6. **CHECK** that the RV landing gear legs (front jacks) are fully **RETRACTED**.
7. **ATTACH** the breakaway switch cable to the tow vehicle. Leave enough slack to accommodate tight turns.
8. **CONNECT** the 7-way wire harness from the RV to your tow vehicle and secure in the travel position.
9. **WALK AROUND** the RV to verify the exterior lights are all working correctly.
10. **REMOVE** the wheel chocks from the trailer wheels.
11. You are now ready to tow the RV.

### G. TOWING THE RV

#### + NOTICE

NEVER allow passengers to ride inside a towable RV while it is in motion. Towable RV's are not designed for occupants during transit and there are no safety or seat belts provided inside your RV. Further, it is against the law in many states for a towable RV to have occupants while in transit.

#### 1. Braking and Stopping Distance

When towing an RV, be sure to allow for greater stopping distances. Before towing the RV, it is best to practice braking and stopping in a large parking lot (where allowed). This will allow you time to become familiar with the RV brake system and practice braking with your RV before driving in traffic. Your RV is a substantial amount of weight behind your tow vehicle, and it is imperative that you are comfortable with the additional distances required to safely stop.

- **AVOID** road conditions and situations that may require excessive and/or prolonged use of the RV brakes.
- Easing into a stop will increase the longevity of the brake life of your RV and tow vehicle. Failure to do so will result in additional wear and tear to the brake systems on both your RV and tow vehicle.

While descending a steep elevation, place the tow vehicle into a lower gear or lower gear range if your tow vehicle has an automatic transmission. This will allow the engine and transmission of the tow vehicle to help regulate the speed of the vehicle itself and in return extend the life of the brakes.

- Engage, then release the brakes in short intervals to allow for cooling.

- When driving in or through deep water, be prepared to increase stopping distances and be aware that wet brakes may cause the vehicle or trailer to pull towards one side or the other.
- If you notice the brakes diminish in effectiveness or are not operating as efficiently, **DO NOT** continue towing the RV until the brakes are inspected and replaced as needed.
- **ALWAYS** check the brake operation of the RV in a safe environment before traveling to ensure proper operation.

## 2. Weight and Clearance Limits

It is important to know the dimensions of the RV, as well as the Combined Gross Weight of the RV and Tow vehicle before traveling. This information is vital to ensure all posted Weight and Clearance Limits are properly followed.

- Remember that the RV height must include the roof air conditioners, TV antennas, solar panels, and floodlights as these may cause clearance issues under some tunnels, canopies, bridges, and/or hanging signs.
- Some bridges, particularly aged ones, may not support the weight of your RV combined with the weight of the tow vehicle. Some bridges may also be too low for your RV to pass under.

## 3. Road Conditions

Adjust driving accordingly to the road and environmental conditions.

- Slow down, then release the brakes prior to crossing railroad tracks or crossways.
- Sudden acceleration or deceleration in wet or icy conditions may cause sliding and ultimately loss of control.
- When there are potholes, dips, or bumps in the road, slow down well in advance to reduce jolting and bobbing of the tow vehicle and RV.

- When driving on uneven surfaces, reduce towing speeds. Before accelerating once more, ensure you are through the uneven section and well onto level surfaces.

## 4. Turning Corners

When turning, the RV will make a tighter turn than your tow vehicle and does not follow in the same path as your tow vehicle. To ensure you compensate for this difference, take wider turns with the RV. In intersections, you must carefully pull into the intersection further, so the RV has proper clearance for the turn.

### WARNING

**While turning, it is critical that you are completely aware of your surroundings and ensure proper clearances. Use caution when making turns to ensure that you avoid collisions with objects around you. When parking in tight locations, utilize a spotter as a guide. Use caution when taking sharp turns and corners and be aware that swerving while towing your RV can result in a loss of control, particularly at higher rates of speed.**

## 5. Passing

When towing an RV, the tow vehicle is under greater load and will take longer to accelerate and reach highway speeds. Allow additional time when pulling out onto a road or while overtaking another vehicle.

When changing lanes, always accommodate for the extra length of your RV. Be cautious of your surroundings and be prepared to change the speed of your tow vehicle and your lane quickly and safely.

## SEC.07 TOWING & LEVELING

### 6. Backing-Up

When selecting a campsite, choose a level site that you can pull through or back into. Prior to parking your RV, inspect the campsite to ensure it satisfies your expectations and that there are no unforeseen obstructions.

- Ensure there is plenty of clearance for the RV.
- Make sure the path is free of ground level and/or hanging obstacles (i.e., large rocks, low dips, low-hanging limbs, electrical lines, etc.).
- It is best to choose a campsite that is on the driver's side.
  - Driver's side campsites allow the driver to better see the rear of the RV while parking.
  - Passenger side campsites hinder parking skills due to it being on the driver's "blind side."
- Position the tow vehicle and RV for backing into the site location.
- Make sure there are no obstructed views before beginning to park your RV.
- When reversing, do so slowly. Use the tow vehicle mirrors and cameras (If Equipped or Customer Supplied) to carefully guide you into the desired parking location.
- Use your passenger as an additional guide to assist you. This will eliminate any hidden blind spots.

### 7. Parking

Once the RV is in the desired position.

- Place the tow vehicle into park and engage any other possible parking brake.
- Turn the ignition of the tow vehicle **OFF** and remove keys.
- Block the wheels of the RV securely with wheel chocks (Customer Supplied).

### H. UNHITCHING FROM THE TOW VEHICLE

After the RV is parked and the wheels are blocked from rolling, it is time to unhitch your RV.

#### UNHITCHING A STANDARD PIN BOX:

1. **STABILIZE** the RV by lowering the front landing gear legs (front jacks). For proper operation, refer to the manufacturer's instructions.
2. **DISCONNECT** the 7-way wire harness/connector plug connecting the RV and tow vehicle.
3. **UNCLIP** the breakaway cable from the tow vehicle.
4. **OPEN** the vehicle tailgate unless it is designed specifically for dovetail hitch connections.
5. Shift the tow vehicle into reverse, but **DO NOT** press the accelerator. This removes pressure off the locking bar, to allow it to properly disengage.
6. Once the pressure is alleviated from the locking bar, apply the brakes and place the tow vehicle back into park.
7. Disengage the locking bar and disconnect the pin box of the RV from the hitch of the tow vehicle.
8. After the pin box is fully released, slowly pull the tow vehicle forward. **DO NOT** pull away at an angle. Doing so may result in damage to the tow vehicle or RV.
9. Level the RV starting from front to back. For proper operation, refer to the level-up manufacturer's instructions. See [Section 8F](#).

### UNHITCHING A GOOSENECK:

1. **STABILIZE** the RV by lowering the front landing gear legs (front jacks). For proper operation, refer to the manufacturer's instructions.
2. **DISCONNECT** the 7-way wire harness/connector plug connecting the RV and tow vehicle.
3. **UNCLIP** the breakaway cable from the tow vehicle.
4. **OPEN** the vehicle tailgate unless it is designed specifically for dovetail hitch connections.
5. Release the coupler lock and begin to lift the RV using the leveling system.
7. Once pressure is released, disengage the locking bar and disconnect the pin box of the RV from the hitch of the tow vehicle.
8. After the pin box is fully released, slowly pull the tow vehicle forward. **DO NOT** pull away at an angle. Doing so may result in damage to the tow vehicle or RV.
9. Level the RV starting from front to back. For proper operation, refer to the leveling manufacturer's instructions. See [Section 8F](#).

### **WARNING**

**DO NOT USE THE LANDING GEAR LEGS (FRONT JACKS) OF THE FIFTH WHEEL TO SUPPORT THE WEIGHT OF THE TOW VEHICLE.**

---

### **WARNING**

**Fully retract the landing legs PRIOR TO moving the RV in any way to prevent damage.**

---

### **NOTICE**

When parking on gravel, dirt, or asphalt on a hot day, place a block of wood or pad under each landing leg to prevent them from sinking into the surface. Make sure the same material is used under each leg to ensure the load remains evenly distributed.

---

# SEC.08 LEVEL-UP HYDRAULIC LEVELING

## A. INTRODUCTION

The Level-Up® 5th Wheel LCD Leveling System is a hydraulic leveling system. This system includes six points of contact utilizing aluminum jacks and a multi-valve system. A 12V DC electric motor drives a hydraulic pump that moves fluid through a system of hoses, fittings, and jacks to level and stabilize the RV.

## B. COMPONENTS

The Level-Up Leveling System is comprised of the following components:

**Jacks**—The unit is equipped with six (6) hydraulic jacks. The two (2) front jacks are commonly referred to as the “landing gear.” The rear four (4) jacks are commonly referred to as the “rear leveling jacks.” All jacks come equipped with 9” (22.86 cm) steel footpads. The jacks are operated by a 12V DC Motor/Pump Assembly.

**Motor/Pump Assembly**—The motor/pump assembly is comprised of the following components:

1. A 12V DC Motor;
2. A hydraulic fluid reservoir tank;
3. A control valve manifold; and
4. A solenoid valve.

**System Controls**—The system can be controlled in fully automatic or manual mode by any of the following methods:

1. The Level-Up Touch Panel located on the driver side of the unit behind the pass-through storage baggage door;
2. The OneControl Touch Panel located in the kitchen hallway near the steps to the upper deck; or
3. Via your cell phone or tablet that is BlueTooth connected to the OneControl system through utilization of the OneControl App.

## C. ADDITIONAL INFORMATIONAL RESOURCES

Additional information about this product can be obtained from [lci1.com/support](https://support.lci1.com/support) or by downloading the free myLCI app. The app is available on iTunes® for iPhone® and iPad® or on Google Play™ for Android™ users. Information regarding the assembly and components of this system can be found online at <https://support.lci1.com/towable-br-level-up-support-towable-level-up-br-touch-pad>.

*iTunes®, iPhone®, and iPad® are registered trademarks of Apple Inc. Google Play™ and Android™ are trademarks of Google Inc.*

## D. SAFETY

### ⚠ WARNING

The Level-Up LCD 5th Wheel Leveling System is designed as a leveling system only and should not be used for any reason to provide service under the trailer, e.g. changing tires or servicing the leveling system. Lippert Components Inc. recommends trained professionals be employed to change the tires or perform other services on the 5th Wheel.

### ⚠ WARNING

Any attempts to change the tires, or perform other service, while 5th Wheel is supported solely by the LCI Level-Up® with Automatic Leveling system could result in death or serious personal injury, severe product and/or property damage.

### ⚠ WARNING

Make sure the 5th Wheel is properly supported with jack stands, or other adequate devices, under the frame of the 5th Wheel prior to performing any service or repair procedure. Never support the 5th Wheel by the axles or suspension. Never allow the tires to leave the ground when lifting the 5th Wheel—this creates unstable and unsafe conditions.



**⚠ WARNING**

Make sure to keep hands and other body parts clear of fluid leaks. Oil leaks in the Lippert Leveling System may be under high pressure and can cause serious skin-penetrating injuries. Make sure all persons, pets and property are clear of the 5th Wheel while LCI Level-Up Automatic Leveling system is in operation.

---

**⚠ WARNING**

A fluid leak within a highly pressurized hydraulic system can cause serious skin-penetrating injuries. Wear appropriate Personal Protective Equipment (PPE), such as long sleeves, gloves, protective eyewear or a full face shield, when performing service or maintenance to the 5th Wheel.

---

**⚠ CAUTION**

Moving parts can pinch, crush or cut. Keep clear and use caution.

1. Make sure the 5th Wheel is parked on a reasonably level surface.
  2. Clear all jack landing locations of debris and obstructions. Locations should also be free of depressions.
  3. When parking the 5th Wheel on extremely soft surfaces, utilize load distribution pads under each jack.
  4. Make sure the battery of the 5th Wheel is fully charged or that the 5th Wheel is plugged into shore power prior to attempting to operate the system.
- 

**+ NOTICE**

Level-Up requires a minimum of 12V DC from the battery for proper operation. It is recommended that the leveling system be operated utilizing a fully charged battery.

---

**+ NOTICE**

The refrigerator and other appliances in the RV are designed to perform best when the RV is level. Additionally, the water system is designed to drain properly when the RV is level.

---

**E. PRIOR TO OPERATION**

The leveling system shall only be operated under the following conditions:

1. The trailer is parked on a reasonably level surface.
2. The tow vehicle is disengaged from the RV.
3. Make sure all persons, pets, and property are clear of the trailer while the Level-Up LCD 5th Wheel Leveling system is in operation.
4. Make sure the battery of the trailer is fully charged or that the trailer is plugged into shore power prior to attempting to operate the system. The automatic leveling system requires a minimum of 12V DC from the battery for operation.

**+ NOTICE**

Slideout rooms should remain in the retracted or in position until the RV is level. Leveling the unit first prior to running out the slideouts will help to prevent water leaks.

---

# SEC.08 LEVEL-UP HYDRAULIC LEVELING

## LCD TOUCHPAD FEATURES

| CALLOUT | DESCRIPTION  |
|---------|--|
| A       | UP ARROW - SCROLLS UP THROUGH THE MENU ON LCD                                |
| B       | DOWN ARROW - SCROLLS DOWN THROUGH THE MENU ON LCD                            |
| C       | ENTER - ACTIVATES MODES AND PROCEDURES INDICATED ON LCD                      |
| D       | RETRACT - PLACES LEVELING SYSTEM INTO RETRACT MODE WHILE IN MANUAL MODE ONLY |
| E       | LCD DISPLAY - DISPLAYS PROCEDURES AND RESULTS                                |
| F       | AUTO LEVEL - PLACES LEVELING SYSTEM INTO AUTO LEVEL MODE                     |
| G       | FRONT BUTTON - ACTIVATES BOTH FRONT JACKS                                    |
| H       | LEFT BUTTON - ACTIVATES LEFT LEVELING JACK(S) IN MANUAL MODE                 |
| I       | RIGHT BUTTON - ACTIVATES RIGHT LEVELING JACK(S) IN MANUAL MODE               |
| J       | REAR BUTTON - ACTIVATES REAR LEVELING JACKS IN MANUAL MODE                   |
| K       | POWER BUTTON (ON/OFF) - TURNS LEVELING SYSTEM ON AND OFF                     |
| L       | LED LIGHTS   |

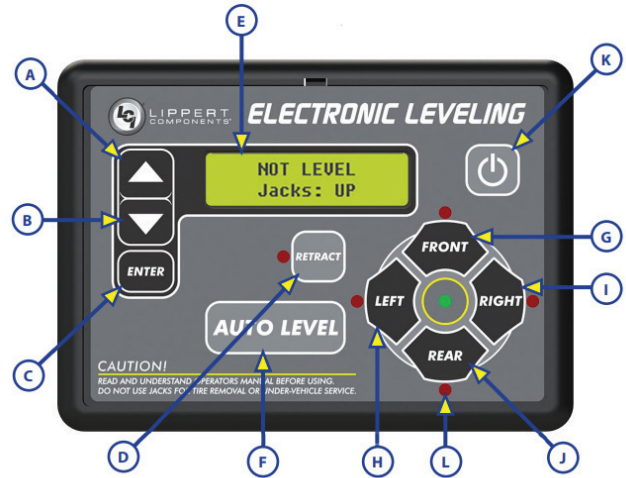

FIG. 1

## F. BASIC JACK OPERATION

### 1. Landing Gear Jacks Operation

- a. Landing gear jacks can be operated any time the system is on, but not in **AUTO MODE**. Press the **FRONT** button (Fig. 1G), so that both the front or landing gear jacks can be extended.
- b. If the touch pad is put in the **RETRACT** mode, indicated by the orange illuminated LED next to the **RETRACT** button (Fig. 1D), the front jacks can be retracted together by pressing the **FRONT** button.

### 2. Level-Up Jacks Operation

- a. The Level-Up jacks operate when “**AUTO MODE**” is activated or the touch pad is in “**MANUAL MODE**”
- b. Once the system is in “**MANUAL MODE**”, press the **REAR** button (Fig. 1J) to extend all Level-UP jacks at the same time.

#### + NOTICE

Manual and Auto modes can be selected through the LCD menu by using the Up and Down Arrow buttons, then press ENTER to select the desired mode.

- c. Press the **LEFT** or **RIGHT** buttons (Fig. 1H or 1I) to operate Level-Up jacks on the left (road) or right (curb) side of the trailer, respectively.

### UNHITCHING INSTRUCTIONS:

1. Press **POWER** button, (Fig. 1K) to turn system on. The LCD screen (Fig. 1E) lights up.
2. The LCD will display “**NOT LEVEL; Jacks: UP**” (Fig. 1E).
3. Orange arrow lights (Fig. 1L) may come on, indicating the current disposition of the trailer.
4. Press **FRONT** button (Fig. 1G) to extend landing gear jacks to lift front of the trailer to take the weight of the 5th Wheel off the hitch.
5. Uncouple the 5th Wheel connection on the tow vehicle.
6. Pull the tow vehicle away and park it at a safe distance.

#### + NOTICE

Prior to unhitching from the tow vehicle, make sure trailer is parked on a level surface and the tires are chocked.

#### + NOTICE

Pressing any button during an Auto Level sequence will abort the auto leveling cycle. In order for the hitch recognition feature to function, the auto level sequence **MUST** be started with the front of the trailer above level.

### AUTO LEVEL SEQUENCE:

1. After unhitching from tow vehicle, press **AUTO LEVEL** (Fig. 1F).
2. Front landing gear will retract, lowering the front of the unit below level, stopping, then lifting the front end to level the unit front-to-back.

3. The left side leveling jack extends and raises the roadside of the unit.
4. The right side leveling jack extends and raises the curbside of the unit, beginning side-to-side leveling.
5. The front landing gear extend to complete the leveling cycle.
6. Additional left-to-right or front-to-back leveling may occur, if the controller deems necessary.

#### + NOTICE

If the auto level sequence does not happen as stated above, check to ensure proper manual function in all zones.

### HITCH RECOGNITION:

1. Turn on touchpad.
2. Press the **LEFT** and **RIGHT** buttons simultaneously (Fig. 1H and 1I).
3. The front of the trailer will raise to the height where the auto level sequence was started.

#### + NOTICE

If the auto level sequence was started with the front of the trailer in a below-level condition, the hitch recognition will not function and the LCD will display “Feature Disabled.” For hitch recognition to function, the auto level sequence must be started with the front of the trailer above level.

4. Connect tow vehicle and make sure 5th Wheel and hitch are connected and locked.
5. Press **UP** arrow (Fig. 1A) arrow until “**AUTO RETRACT**” appears in LCD screen.
6. Press **ENTER**. System will immediately retract all jacks.

# SEC.08 LEVEL-UP HYDRAULIC LEVELING

## G. TROUBLESHOOTING

### Error Codes

To clear an error from the touch pad, repair or otherwise correct the issue, press **ENTER**. If the error is still present, the message will be displayed again.

After working to resolve the issue that led to an error code, press **ENTER** on the touchpad. If the error is still present, the message will be displayed again. If resolved the error message will clear.

| ERROR CODES                          |  |   |
|--------------------------------------|--|---|
| LCD MESSAGE                          | WHAT'S HAPPENING   | WHAT SHOULD BE DONE?  |
| "EXCESS ANGLE"                       | CONTROLLER NOT PROPERLY SECURED  | CHECK AND SECURE CONTROLLER PLACEMENT   |
|                                      | EXCESSIVE ANGLE REACHED DURING AUTO OPERATION  | RELOCATE THE 5TH WHEEL  |
| "EXCESSIVE ANGLE"                    | CONTROLLER NOT PROPERLY SECURED  | CHECK AND SECURE CONTROLLER PLACEMENT   |
|                                      | EXCESSIVE ANGLE REACHED DURING MANUAL OPERATION  | RELOCATE THE 5TH WHEEL  |
| "FEATURE DISABLED"                   | FRONT OF 5TH WHEEL BELOW LEVEL WHEN STARTING AUTO-LEVEL PROCESS (ONLY WHEN TRYING TO INITIATE HITCH RECOGNITION) | PUSH THE <b>FRONT</b> BUTTON TO RAISE THE 5TH WHEEL UP TO HITCH HEIGHT AND CONNECT TO TOW VEHICLE |
|                                      | TOUCHPAD POWER NOT CYCLED BETWEEN CONSECUTIVE LEVELING OPERATIONS  | TURN TOUCHPAD OFF AND THEN BACK ON TO RESET THE SYSTEM  |
|                                      | ZERO POINT NOT SET   | SET ZERO POINT  |
| "LOW VOLTAGE"                        | BATTERY VOLTAGE DROPPED BELOW 9.5 V  | CHECK WIRING - REPAIR OR REPLACE  |
| "OUT OF STROKE"                      | JACK HAS REACHED MAXIMUM STROKE LENGTH AND IS UNABLE TO LIFT   | TEST BATTERY VOLTAGE OF JACKS AND/OR RELOCATE THE 5TH WHEEL                                       |
| "EXTERNAL SENSOR"                    | BAD CONNECTOR OR WIRING FROM THE CONTROLLER TO THE SENSOR  | REPLACE OR REPAIR CONNECTION TO REMOTE SENSOR   |
| "JACK TIME OUT"                      | TIME LIMIT EXCEEDED FOR THE REQUESTED AUTO OPERATION   | CHECK DISPOSITION OF JACKS  |
| "AUTO LEVEL FAIL"                    | UNABLE TO AUTO-LEVEL DUE TO UNEVEN GROUND  | CHECK DISPOSITION OF JACKS AND/OR RELOCATE THE 5TH WHEEL  |
|                                      | UNABLE TO AUTO-LEVEL DUE TO ZERO POINT BEING SET INCORRECTLY   | RESET ZERO POINT  |
| "BAD CALIBRATION"                    | SENSOR CALIBRATION VALUES ARE OUT OF RANGE   | REPLACE CONTROLLER  |
| "INTERNAL SENSOR"                    | INTERNAL SENSOR PROBLEM  | REPLACE CONTROLLER  |
| **PANIC STOP**<br>"FUNCTION ABORTED" | THE USER PRESSED A BUTTON ON THE TOUCHPAD DURING AN AUTOMATIC OPERATION  | RESTART AUTOMATIC OPERATION AND THEN REFRAIN FROM PRESSING ANY BUTTONS ON THE TOUCHPAD            |

**⚠ WARNING**

Make sure the trailer is supported at both the front and rear with jack stands before performing any troubleshooting or service to the trailer. Failure to do so may result in death or personal injury.

**Manual Override**

The Level-Up LCD 5th Wheel Leveling system can be manually operated with an electric drill. In the event of electrical or system failure, this manual override method of extending and retracting the jacks can be used.

**+ NOTICE**

Unhook the hydraulic power unit motor from the main power source (battery or shore power) prior to attempting the manual override procedure.

**MANUALLY OVERRIDING THE HYDRAULIC SYSTEM:**

1. Locate the valves that are paired with the landing gear or leveling jack to be manually overridden.
  - a. Landing Gear–Valve located on the lead landing gear (**Fig. 2**).
2. Using a 5/32" hex wrench, open the valve by turning the manual override set screw clockwise (**Fig. 3**).
3. Remove protective label (**Fig. 4A**) from power unit motor revealing manual override coupler.
4. Using an electric drill with a 1/4" hex bit, insert the hex bit into the manual override coupler (**Fig. 5**) to manually operate the system.
  - a. Run the drill forward (clockwise) (**Fig. 5A**) to retract the landing gear or leveling jacks.
  - b. Run the drill in reverse (counterclockwise) (**Fig. 5B**) to extend the landing gear or leveling jacks.
5. Make sure to turn the manual override set screw on the valve back to the counterclockwise position after extending or retracting the landing gear or leveling jacks (**Fig. 6**).

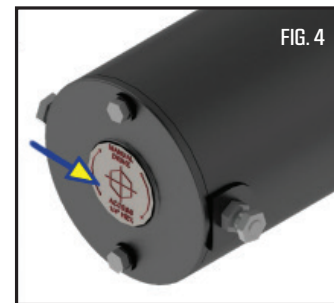
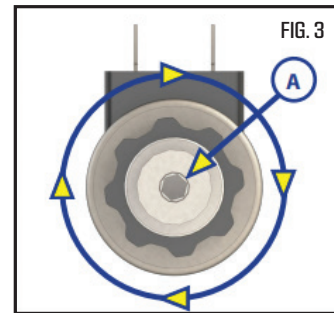
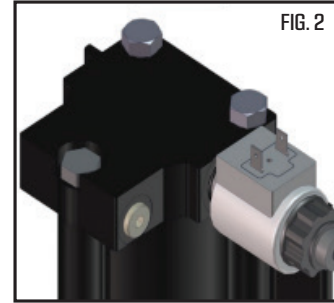

PROTECTIVE LABEL

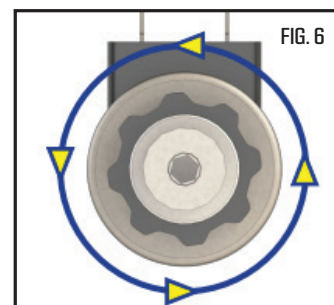
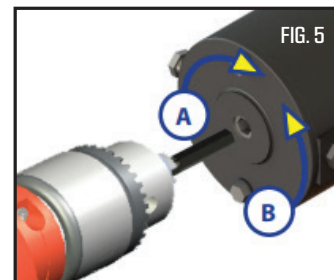

# SEC.08 LEVEL-UP HYDRAULIC LEVELING

## H. ZERO POINT CALIBRATION

The “Zero Point” is the programmed point to which the 5th Wheel will return whenever the auto-level feature is used. The Zero Point is preset at the factory and should never have to be reset. However, if necessary, Zero Point can be reset.

### + NOTICE

The Zero Point must be programmed prior to using the auto-level feature to ensure the proper operation of the system. Prior to starting the Zero Point Calibration procedure, check all connections on the controller, valve coils, landing gear, leveling jacks and touchpad.

1. Manually run all leveling jacks and landing gear to level the 5th Wheel.
  - a. This is best achieved by placing a level in the center of the 5th Wheel and leveling it both front-to back and then side-to-side.
  - b. See Basic Jack Operation section for instructions on how to manually operate the system.
2. After the 5th Wheel has been leveled, turn off the touchpad.
3. With the touchpad off, press and release the FRONT button (Fig. 1G) ten times and then press and release the REAR button (Fig. 1J) ten times.
4. The touchpad will flash and beep, then the LCD screen will read “ZERO POINT CALIBRATION ENTER to set, Power to Exit” (Fig. 7).

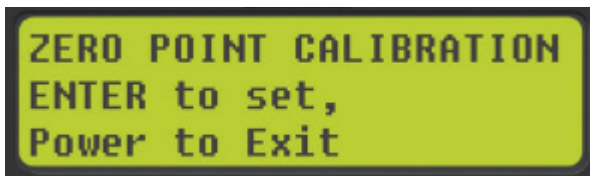

FIG. 7

5. To set the current position as the zero point, press the ENTER button (Fig 1C). Thereafter, the LCD display will read “ZERO POINT stability check” (Fig. 8).



FIG. 8

6. LCD display will read “ZERO POINT set successfully” once the process is complete (Fig. 9).



FIG. 9

7. The system will set this point as its level state and the touch pad will turn off.

## I. MAINTENANCE

1. Remove dirt and road debris from leveling jacks and landing gear and stabilizer struts (If Equipped) as needed.
2. If jacks are down for extended periods, it is recommended to spray exposed jack tubes with a spray lubricant every three months for protection. If the 5th Wheel is located in a salty air environment, it is recommended to spray the jack tubes every 4-6 weeks.
3. Each month, check that the fluid level is within 1/4" (6.35 mm) of the fill spout lip while leveling jacks and slideouts are fully retracted.



### + NOTICE

Always fill the reservoir with the leveling jacks and slide-outs fully retracted. Filling the reservoir when leveling jacks and slide-outs are extended will cause the reservoir to overflow into its compartment when the leveling jacks and slide-outs are retracted.

4. Inspect and clean all of the 5th Wheel's power and electrical connections prior to the first use of the 5th Wheel at the start of the traveling season and prior to storing the 5th Wheel. If corrosion is evident, clean all corrosion with a wire brush, then apply dielectric grease to the connections.
5. Make sure to turn the manual override set screw on the valve back to the counterclockwise position after extending or retracting the landing gear or leveling jacks.

### Fluid Recommendation

Automatic transmission fluid (ATF) with Dexron® III or Mercon® V or a blend of both is recommended by Lippert Components, Inc. For a list of approved fluid specifications, go to <https://lci-support-lci4a3lcd>. Then click on the Technical Information sheets tab. Look for TI-188: Hydraulic Operation Fluid Recommendation within the listing.

### + NOTICE

In colder temperatures (less than 10° F (-12.2° C) the jacks may extend and retract slowly due to the fluid's molecular nature. For cold weather operation, fluid specially formulated for low temperatures may be desirable.

### Preventive Maintenance

1. Check hydraulic fluid in reservoir every 12 months. If fluid is a clear, red color, do not change. If fluid is milky, pink and murky, and not clear red in color, drain reservoir and add new fluid. Hydraulic fluid in reservoir should be changed a minimum of every five years.

### + NOTICE

Check the fluid only when all the jacks are fully retracted. When checking the hydraulic fluid level, fill to within 1/4" to 1/2" (6.35-12.7 mm) of fill spout.

2. Inspect and clean all power unit electrical connections every 12 months. If corrosion is evident, use a small amount of lubricant to remove corrosion. Contacts must be cleaned with a non-residue cleaner prior to use. LCI recommends the use of an electrical contact cleaner spray.
3. Remove dirt and road debris from jacks as needed.

### ⚠ WARNING

**The RV should be supported at both front and rear axles with jack stands before working underneath. Failure to do so may result in death, serious personal injury or severe product or property damage.**

4. If jacks are down for extended periods, it is recommended to spray exposed jack rods with a dry silicone lubricant every three months for protection. If the trailer is located in a salty environment, it is recommended to spray the rods every four to six weeks.

# SEC.08 LEVEL-UP HYDRAULIC LEVELING

## WIRING DIAGRAM - 6-POINT LEVEL-UP

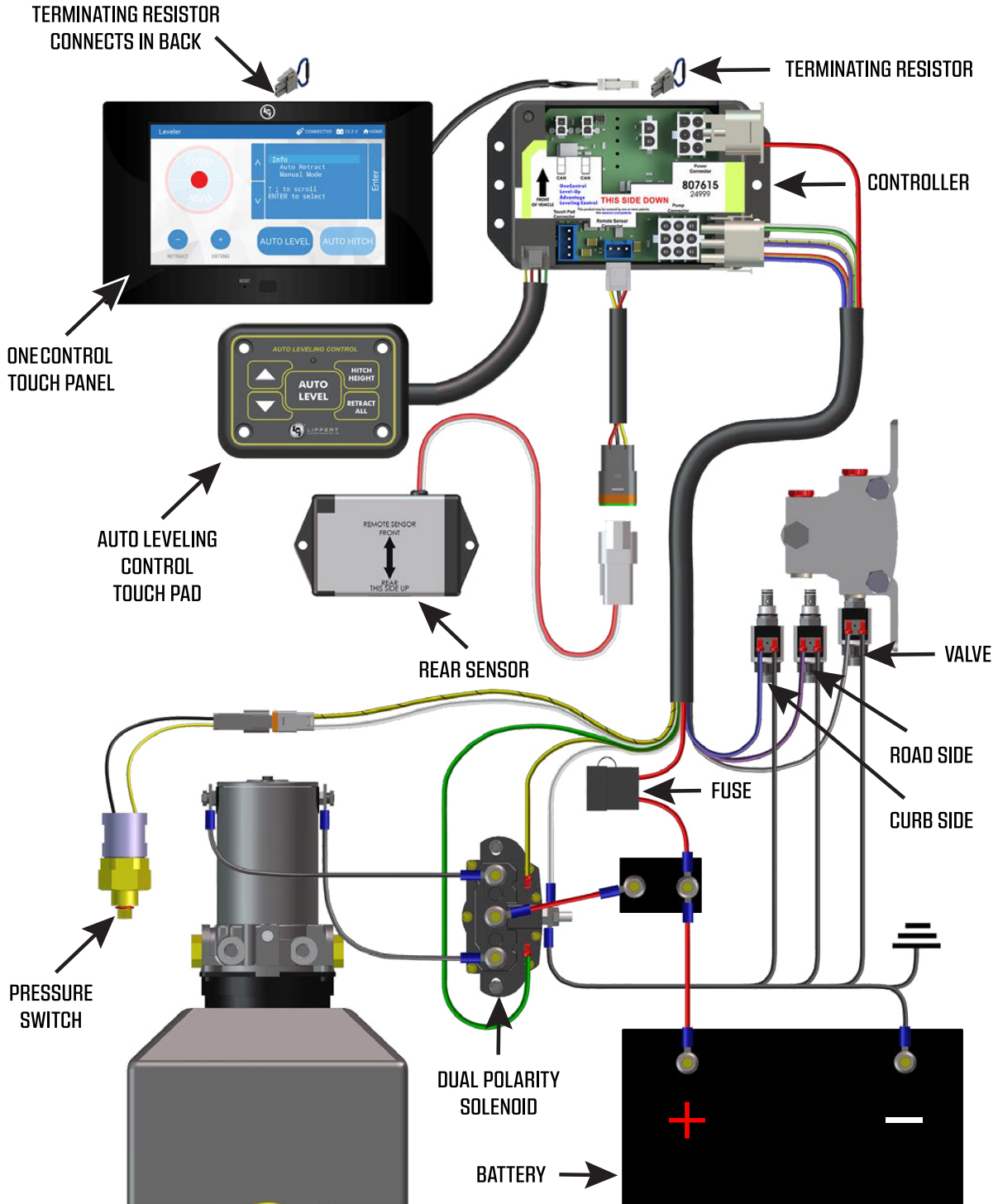

BRINKLEY CUSTOMER CARE: phone: 888.502.3460 or 574.501.4280 / email: CustomerCare@BrinkleyRV.com  
 SAFERIDE 24/7 - EMERGENCY ROADSIDE ASSISTANCE: 888.482.5715 / Customer Service: 855.963.1770

PLUMBING DIAGRAM - 6-POINT LEVEL-UP

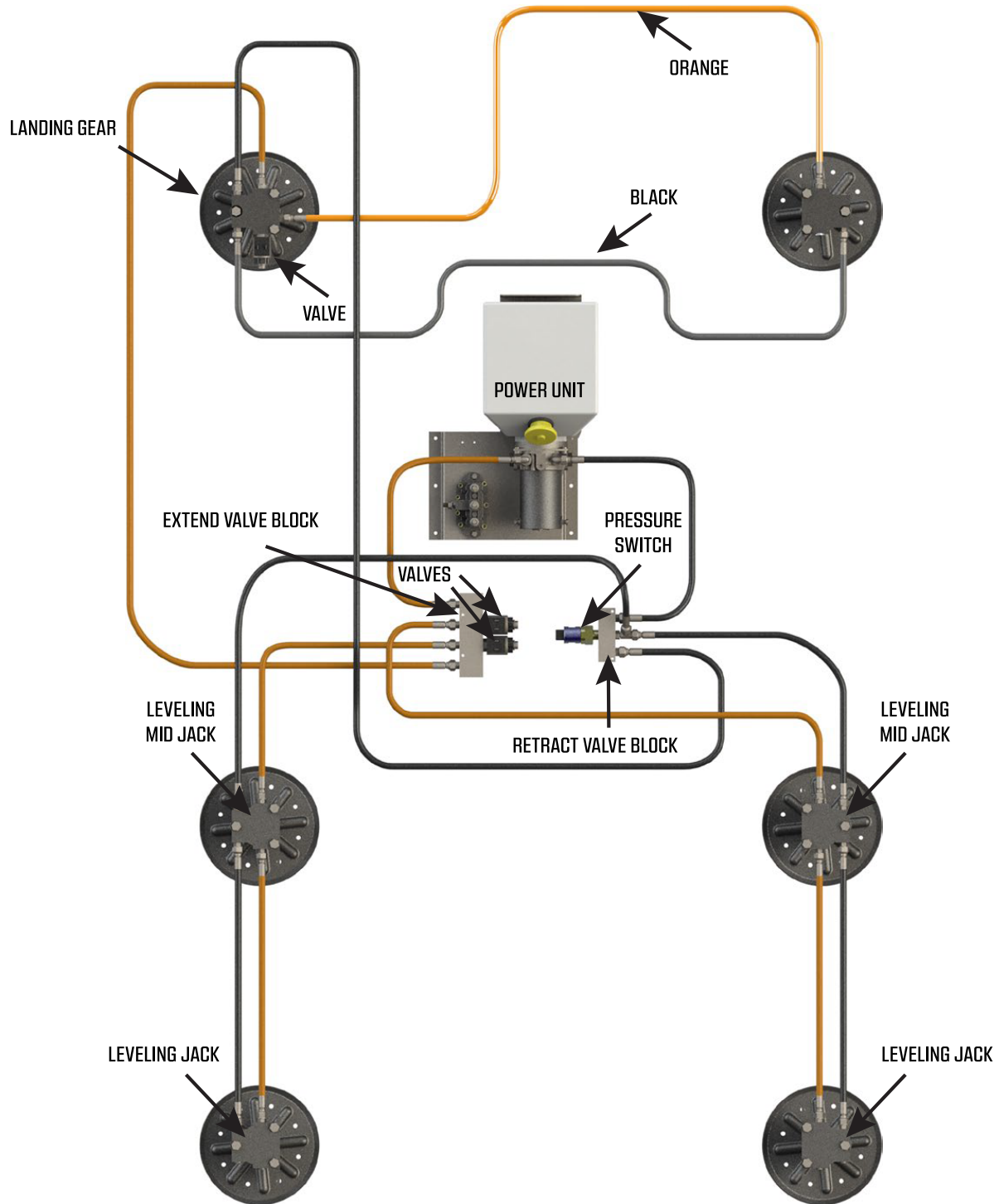

# SEC.09 SLIDE-OUT SYSTEMS

## A. GENERAL INFORMATION

Slide-out rooms are designed to provide you additional living space during stationary camping.

- To extend, retract, and to seal a slide-out correctly, the RV must be level. If the RV is NOT level, the slide-out rooms and/or their pertaining parts may become damaged or leak.
- Slide-outs do not need additional support. Any damage that results from such support may not be covered under the warranty. This includes any damage that may result from the improper use or use of aftermarket support jacks.

### ⚠ WARNING

Before operating any slide-out, review and understand all operation instructions and safety alerts.

### ⚠ WARNING

Slide-outs and slide-out mechanisms are crush hazards. Disable the auxiliary battery and flip the breaker on the distribution panel to cut power to the converter **BEFORE** working on or under a slide-out. Failure to do so may result in serious injury or death.

### ⚠ WARNING

Before extending or retracting a slide-out, make sure the surroundings are clear of objects, people, and pets. Failure to do so could result in serious injury or death.

### + NOTICE

Prior to operating a slide-out, ensure sufficient power is available and that the RV is properly leveled. Failure to do so may result in damage to your slide-out or slide-out mechanism.

## B. OPERATION

It is normal for slide-outs to make noises such as squeaking or creaking while being operated. These noises are more common during the “break in period” of the RV and will continue until components and materials are seated properly. After a few uses, this noise will likely reduce.

### SLIDE-OUT OPERATION:

1. **BEFORE** operating any slide, level and stabilize the RV.
2. Ensure wheels are properly chocked.
3. Ensure there is a energy source. If power is supplied by the campground, make sure you are properly connected. If you are running the slides with auxiliary power, make sure the battery is fully charged and all unnecessary lights and power consumption is limited to maximize available power for slide-out operation.
4. **PRIOR TO** extending or retracting the slide:
  - a. Close all cabinet doors and drawers.
  - b. Ensure the interior path for the slide-out is clear of people, pets, furniture, and/or any other possible object that may obstruct the slide-out’s path.
  - c. Ensure the exterior path for the slide is free of trees, electric lines, or any other possible obstructions.
5. To extend, press and hold the **OUT** or **EXTEND** button on the Brinkley OneControl touch panel or OneControl App. Refrain from releasing operation until the slide motor stalls. If there is an obstruction, stop operation immediately. A slight delay may occur before the slide-out begins to move. This is normal.

6. **BEFORE** retracting, inspect the exterior walls, roof, and floor of the slide-out. If any of the surfaces are wet, be sure to dry them before retracting.
7. If water puddles or debris are present from the use of a slide, clean and dry the area immediately.
8. To retract, press and hold the **IN** or **RETRACT** button on the Brinkley OneControl touch panel or OneControl App. Refrain from releasing operation until the motor stalls and the room is completely retracted. If there is an obstruction during operation, stop immediately.

#### + NOTICE

There will always be some noise that accompanies the operation of extending and retracting the slide-out.

#### ⚠ WARNING

The slide-out mechanism contains sharp edges. To prevent injury, **DO NOT** allow children to play under the slide-out under any circumstance. **BEFORE** working on or going under a slide-out, make sure **ALL** power to the slide is disconnected. Failure to do so may result in serious injury or death.

#### ⚠ WARNING

Ensure all slide-outs are fully retracted **PRIOR TO** hitching the RV to the tow vehicle. Failure to do so may result in damage to your RV, serious injury, or death.

#### ⚠ WARNING

Ensure the interior and exterior path for the slide-out is clear of people, pets, furniture, and/or any other possible object that may obstruct the slide-out's path. Failure to do so may result in damage to your RV, serious injury, or death.

#### + NOTICE

For the slide-out to seal correctly, the room must be fully extended or retracted. Once the slide-out is fully extended or retracted, release the slide switch immediately. Running the switch beyond slide extension may result in damage to the slide-out motor.

## C. SLIDE-OUT MAINTENANCE

While a slide-out is fully extended, the slide surfaces will be exposed to and will collect water, dirt, ice, and other miscellaneous debris. Slide-out seals are not designed to remove such debris. All slide-out exterior surfaces should be dry and clean prior to retracting the slide.

#### PRIOR TO RETRACTING A SLIDE:

- Inspect the outside surfaces for snow, ice, dirt, water, insect nests, etc.
- Check for standing water, snow, or ice on slide-out awning toppers (If Equipped).
- Clean and dry all exterior surfaces of the slide-out and the slide-out mechanism as much as possible.



## SEC.09 SLIDE-OUT SYSTEMS

### ⚠ CAUTION

Before operating a slide-out, the RV must be leveled. Water leaks and other problems may result from the RV being unlevel.

### ⚠ WARNING

Do not place excessive weight within the slide-out. Overloading a slide-out may result in malfunction leading to damage to the slide mechanism, injury, or death.

### + NOTICE

For long-term storage, it is recommended that all slide-outs be stored with slide rooms fully retracted.

For troubleshooting and/or repair, please contact your Authorized Dealer or Brinkley RV Customer Care team. Examples of when to contact may include, but are not limited to, the following:

- Slide motor stalls before the slide reaches full extension or retraction.
- Slide does not properly close or seal correctly.
- Slide retracts or extends unevenly.
- Slide makes unusual sound upon operation.



BRINKLEY ONECONTROL TOUCH PANEL

## D. LIPPERT THROUGH FRAME HYDRAULIC SLIDE-OUT SYSTEM

One slide mechanism utilized by Brinkley RV is the Lippert Through Frame Hydraulic Slide-out System. This system's function is to allow the slide room to extend and retract at the push of a button. The through-frame hydraulic system is a **rack-and-pinion** guided system utilizing a hydraulic cylinder to move the room assembly and is operated as a negative ground system.

The power unit pressurizes the hydraulic transmission fluid and the fluid pressure then causes the cylinder rod to extend and retract. Please refer to the manufacturer's manual for complete instructions on use, maintenance, limitations, and warnings: <https://lci-support-doc.s3.amazonaws.com/manuals/slideouts/ccd-0001616.pdf>.

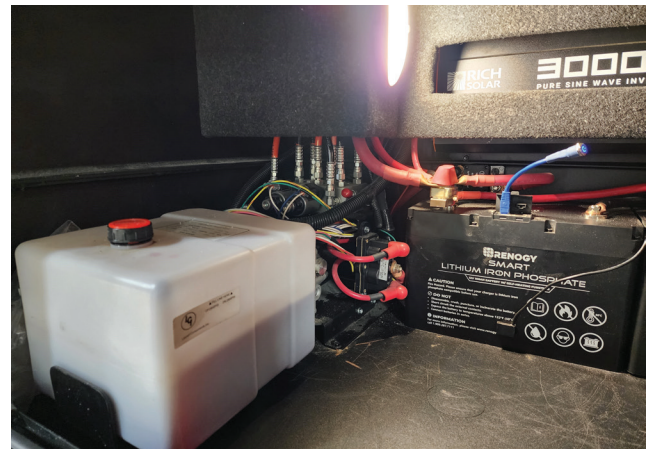

POWER UNIT OR HYDRAULIC PUMP

### 1. Manual Operation

The Lippert Through Frame Hydraulic Slide-out System comes with a manual override feature. To manually override the system, see the instructions below. Locate the Manual Drive Access found at the end of the power unit and follow the instructions found on the following page.



**MANUAL OVERRIDE:**

1. Locate Manual Drive Access at the back of the pump assembly found in the front compartment of your RV.

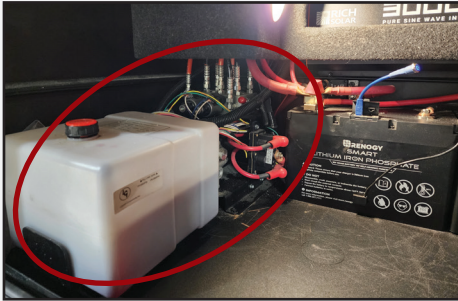

2. Remove the protective label (**Fig. 7A**).

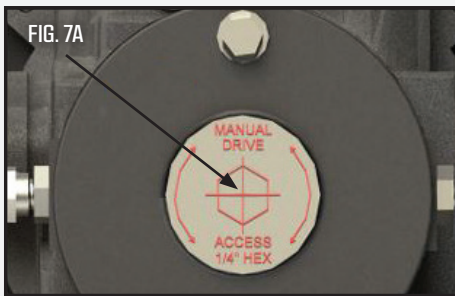

3. Using a standard hex bit and auxiliary drive device (cordless or electric drill), insert the hex bit into coupler found under the protective label (**Fig. 8**).

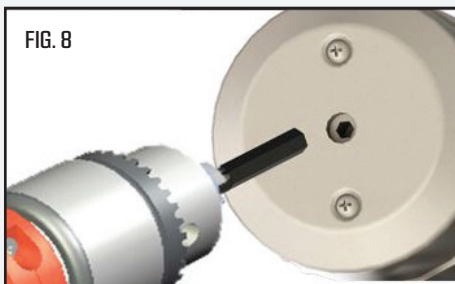

4. Run the drill counterclockwise to extend slide-out room and clockwise to retract slide-out room.

**2. Maintenance**

The slide-out mechanism is designed for minimal maintenance. Operate each slide-out once or twice a month to keep the seals and all other internal moving parts lubricated and flexible.

- For best operation, the auxiliary battery should be fully charged and the hydraulic fluids should be properly set/filled.

**+ NOTICE**

Please visit, <https://lci-support-doc.s3.amazonaws.com/technical-information-sheets/leveling-and-stabilization/ccd-0002088.pdf> for approved hydraulic fluid types.

- Inspect for loose, corroded, or damaged components at the battery terminals, control switch, and hydraulic pump assembly.
- When operating the slide-out system in harsh environments (i.e., road salt, environmental salts, ice buildup, under trees, etc.) keep all moving parts clean and clear of debris.
  - Remove all ice buildup and other debris.
  - Dry all water that is collected.
  - Wash as needed with mild soap and water and then dry.
- Apply dry, non-silicone-based lubricants as needed.

For additional maintenance instructions, please refer to the [Lippert's Hydraulic Through Frame Slide-Out System Service Manual](#).

**3. Service and Adjustments**

- Every 90 days, slide-out's should be inspected to ensure proper function of the slide and its seals, and fluids should be filled as needed.
- Every 6 months, slide-out rooms should be adjusted and inspected by a certified RV service technician.
- Any adjustments made by non-certified person or entity may void the warranty.

# SEC.09 SLIDE-OUT SYSTEMS

## E. LIPPERT IN-WALL SLIDE-OUT SYSTEMS—SLIMRACK®

### 1. General Information, Extending, and Retracting

Another slide system utilized by Brinkley RV is the Lippert SlimRack® system. Unlike a through frame that passes through the RV chassis, this system is mounted to the wall structure of the slide-out box.



As you can see in the picture directly above, the SlimRack system has two gear racks on either side of the slide room.

#### + NOTICE

It is normal for slides to make noises such as squeaking or creaking while being operated. These noises are more common during the “break in period” of the RV and will continue until components and materials are seated properly. This will lessen over time.

The controller for the SlimRack system is located in the bulkhead storage compartment. A picture of the controller is provided below. If you experience issues with your SlimRack, Review the controller for the flashing error code and then refer to Lippert’s manual for assistance.



The operating instructions for this system are provided below.

### OPERATE THE SLIMRACK SLIDE-OUT SYSTEM:

1. **BEFORE** operating any slide, level and stabilize the RV.
2. Ensure wheels are properly chocked.
3. Ensure there is a sufficient energy source. If power is supplied by the campground, make sure you are properly connected. If you are running the slides with auxiliary power, make sure the battery is fully charged and all unnecessary lights and uses are limited to maximize available power.
4. **PRIOR TO** extending or retracting the slide:
  - a. Close all cabinet doors and drawers.
  - b. Ensure the interior path for the slide-out is clear of people, pets, furniture, and/or any other possible object that may obstruct the slide-outs path.
  - c. Ensure the exterior path for the slide is free of trees, electric lines, or any other possible obstructions.
5. To extend, press and hold the **OUT** or **EXTEND** button on the Brinkley OneControl touch panel or OneControl App. Refrain from releasing operation until the slide motor stalls. If there is an obstruction, stop operation immediately. A slight delay may occur before the slide-out begins to move. This is normal.
6. **BEFORE** retracting, inspect the exterior walls, roof, and floor of the slide-out. If any of the surfaces are wet, be sure to dry them before retracting.

7. If water puddles or debris are present from the use of a slide, clean and dry the area immediately.
8. To retract, press and hold the **IN** or **RETRACT** button on the Brinkley OneControl touch panel or OneControl App. Refrain from releasing operation until the motor stalls and the room is completely retracted. If there is an obstruction during operation, stop immediately.

## 2. Troubleshooting

On the SlimRack controller, you will find the below diagnostic label.

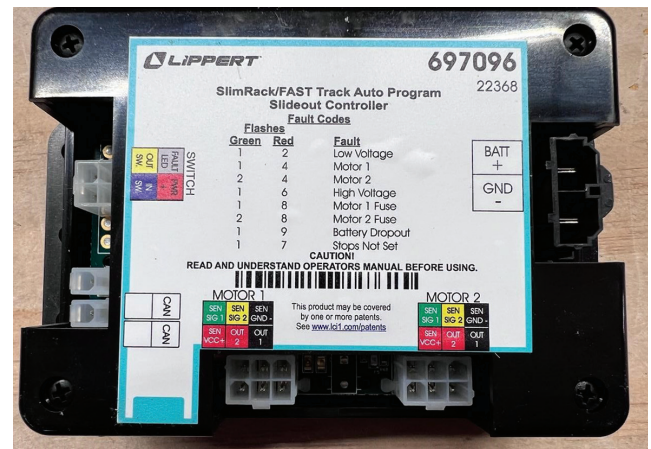

For troubleshooting information, please refer to the [Lippert SlimRack Slide-Out Owner's Manual](#).

# SEC.10 HAPPIJAC POWER BED LIFT SYSTEM

## A. INTRODUCTION

Your RV is equipped with a HappiJac Power Bed Lift system. The HappiJac Power Bed Lift effectively maximizes existing vertical space, providing room for additional storage or sleeping/sitting area. This system is comprised of an upper, queen sized bunk and two lower, reversible sofas on a vertical lift system.

This entire system can be operated by the touch of a button at the monitor panel. This monitor panel is located on the wall that separates the garage and main living. A photo of the panel is shown below.



## B. SAFETY PRECAUTIONS

Prior to operating the HappiJac lift system, there are a few safety precautions that should be taken into consideration.

- ALWAYS raise the bed(s) to the full up position when the trailer is being towed to avoid damage to the bed lift system as a result of road vibration.
- ALWAYS make sure that the areas above, below and adjacent to the bed(s) are free from obstructions before operating the bed lift.
- ALWAYS check before operating lift to ensure that there is nothing interfering with the travel of the chain mechanism inside the c-channel.
- ALWAYS use care when loading cargo/vehicles in the garage area. This is to avoid damage to the bed mechanism.
- ALWAYS properly secure loads in the garage area to avoid damage to the bed mechanism from shifting or falling loads.

- NEVER operate the bed lift with any items other than bedding on the bed platform(s).
- NEVER travel with any items other than bedding on the bed(s), unless secured. Loose items can become projectiles.
- NEVER operate the bed lift when persons or pets are on the bed platform.
- NEVER hang from, or hang more than 20 pounds, on the cross-connecting shaft.

## ⚠ CAUTION

Moving parts can pinch, crush or cut. Keep clear and use caution.

## C. OPERATION

Prior to operating the HappiJac Power Bed Lift System, please be aware of all the warnings, instructions, and information found in the manufacturer's manual.

### 1. General Operation

The general operation of the HappiJac Power Bed System is relatively simple and can be performed by only one person. Please see the instructions below.

### OPERATING THE BED LIFT:

1. Locate the monitor panel in the garage area. Press and hold the bed lift UP button shown in the below photo to raise the bed lift.





2. Continue to hold the UP button until the limit switches (microswitches) stop the lift's movement. Your bunks will now be in the up/stowed position.



3. Press and hold the DOWN button until the limit switches stop the lift's movement. Your bunks will now be in the down position.

## 2. Stowing/Locking the Upper Bunk

The bed lift system has a stow feature for the top bunk which leaves it in the travel position at the ceiling while allowing the lower bunk/sofas to travel independently.

### + NOTICE

Prior to traveling with your RV, the upper bunk should always be placed in travel mode.

### STOWING/LOCKING THE UPPER BUNK:

1. Rotate both the lower sofas into their bunk positions.



2. Locate the locking mechanism found at each vertical post of the lift assembly. Flip the locking mechanism tab shown in the top right photo so the long portion of the tab is outside of the C-channel.

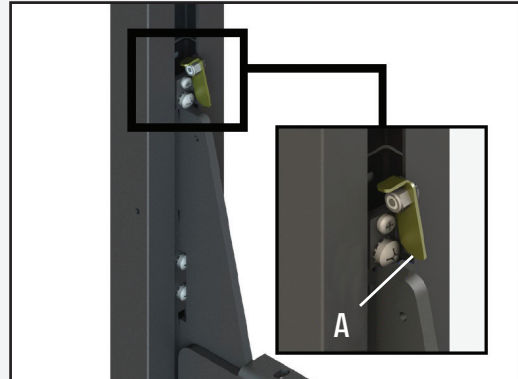

3. Repeat step 2 at each locking mechanisms.
4. Locate the operation switch at the monitor panel, and run the lift system until both bunks are in the closed or up/stowed position.



### + NOTICE

There is an audible click when the locking mechanism engages. If the mechanism fails to latch, check to make sure the bunk lock assembly bolt is not too tight and that the bunk lock assembly mechanism springs back freely within the C-channel.

5. Lower the bottom bunk to the desired height.
6. Return the lower bunk to sofa position if desired.

### + NOTICE

Utilize steps 1 through 4 to place the Happijac system into travel mode. Omit steps 5 and 6.

# SEC.10 HAPPIJAC POWER BED LIFT SYSTEM

## 3. Un-Stowing/Releasing the Upper Bunk

To release the upper bunk from stow mode, follow the below steps:

### UN-STOWING/RELEASING THE UPPER BUNK:

1. Rotate both the lower sofas into their bunk position if they are not already in this position.



2. Flip the locking mechanism tab shown in the below photo to the release position, where the long portion of the tab is inside the C-channel. Repeat for the other locking mechanisms at each vertical post of the bed lift.

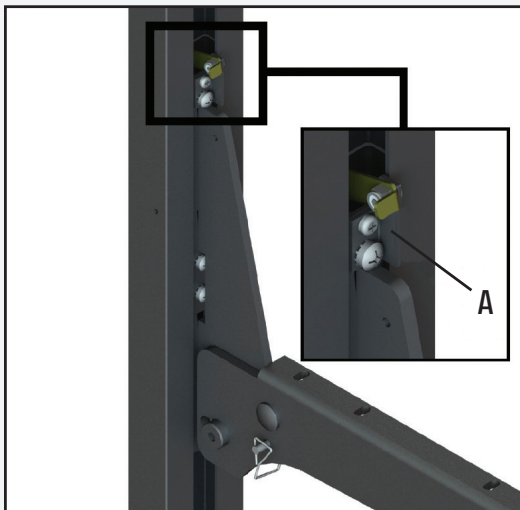

3. Run the lift system until both bunks are in the closed or up/stowed position.



4. Press the UP button on the monitor panel to further lift the upper bunk. This will release the bunk from the locking mechanism.



5. Press the DOWN button on the monitor panel to lower the upper and lower bunk/sofas.





## D. HAPPIJAC SOFA CONFIGURATIONS

### 1. Bunk Mode

Bunk Mode is when you have both reversible sofas laying horizontally flat to form one bunk. For additional information on how to transform your sofas into a bunk, please See [Section 22E](#).

### 2. Sofa Mode

Sofa mode is when you have both reversible sofas in an upright position, forming two separate sofas. For additional information on how to transform your reversible sofas into a standard sofas, please See [Section 22E](#).

### 3. Flush Wall Storage Mode

When loading your RV, additional headspace may be needed when loading specific cargo, vehicles, and/or equipment. For this purpose, the reversible sofas were designed to lay flush against the RV wall. To utilize this feature, the below instructions should be followed.

#### PLACING THE SOFAS INTO FLUSH WALL STORAGE POSITION:

1. Place one sofa into the bunk mode while keeping the other in sofa mode.



2. Remove the lockpins securing both bracket arms. These are located on the backside of the sofa. There will be one at each end of the sofa. Be prepared for the weight to shift as you remove the second pin from the sofa bracket.



3. Pull up slightly on the bracket arm, then pull in an outward motion. This will release the sofa from the bracket and will allow the sofa to pivot downward.



4. Gently lower the sofa to allow it to rest flush against the RV wall.



5. Re-insert lockpins



# SEC.11 ELECTRICAL SYSTEMS

## A. GENERAL INFORMATION

Your Brinkley RV Fifth Wheel is equipped with a 120-volt 60hz AC power and a 12-volt DC power system. The electrical system and all its components are engineered and designed specifically for RV's. All installations and components utilized meet or exceed the RV industry standards applicable as of the date the RV is manufactured.

- Hazardous conditions may occur as a result of aftermarket modifications or additions made to the RV pertaining to the RV electrical system.
- Modifying or making unauthorized additions within the RV is NOT recommended by Brinkley RV.
- ONLY your Authorized Dealer or a qualified electrical technician should perform service to the electrical system within the RV.

When providing maintenance or repairs to the RV, only components, methods, and materials that follow current safety and code requirements are permitted. Please consult with your Authorized Dealer's Service Center for assistance.

### ⚠ WARNING

Use caution when working on the electrical system, especially when using metal tools. When a metal tool encounters a live, powered source it will cause the system to short circuit potentially resulting in personal injury, property damage, explosion, or fire.

## B. ELECTRICAL SYSTEM MAINTENANCE

- **BEFORE** working on or near an electrical system, **ALWAYS** disconnect the negative 12-volt terminal on the battery and the shore power cord.
- **PRIOR TO** disconnecting the battery, **ALWAYS** make sure the power to the converter is turned off. Failure to do so, may result in damage to your RV or personal injury.

For more information on the electrical system within the RV, please refer to the component manuals in the Owner Information Package.

### ⚠ WARNING

The power cord **MUST** be fully extended and not coiled on the ground or in the compartment when in use. When the power cord is left in a coil, it may generate enough heat to melt the protective casing resulting in damage to the RV, personal injury, or fire.

## C. 50-AMP POWER CORD

The power cord commonly referred to as the shore cord or shore power cord connects the RV to an external power receptacle commonly found at campsites (see picture below).



## 1. Shore Cord Power

The purpose of this power is to:

- Supply an electrical feed from the external power receptacle to the RV.
- Supply proper ground to the electrical system within the RV from the external power source.

### CONNECTING POWER:

1. Disconnect power to the load center by flipping the main 120-volt circuit breaker.
2. Extend the shore cord from the RV and fully stretch the cord so it is not coiled.
3. Connect the shore cord to the RV.
4. Plug the shore cord into the external power source provided. Ensure that all prongs on the shore cord are fully seated within the external receptacle.
5. Returning to the RV, flip the load center breaker back to the ON position.
6. Follow the below instructions to help prevent damage from occurring due to power surges:
  - a. Disconnect the shore power cord any time the RV is left unattended. This will lessen the damage if a power surge were to occur while you are away from the RV.
  - b. Prevent damage from occurring to the prongs of the shore cord when connecting and disconnecting from external power sources.
  - c. When departing or needing to disconnect the power source, follow steps:
    - i. Unplug the shore cord from the external power source.
    - ii. Disconnect the shore cord from the RV.
    - iii. Recoil the shore cord via the cord reel.

### + NOTICE

PRIOR TO connecting the RV to ANY external power source, ALWAYS test the external power with a Line Monitor or Clarity Tester (Customer Supplied). If the receptacle or source indicates Reverse Polarity or an open ground, DO NOT connect the RV.

### + NOTICE

NEVER disconnect the power cord, or shore cord, at the RV. Always disconnect the power cord, or shore cord at the external receptacle. Also, never remove the power cord by pulling on the cable. Always disconnect by pulling on the end connector that plugs into the outlet.

## 2. Power Cord Maintenance

Frequently inspect the components of the power cord for cracks, cuts, worn/melted insulation, and exposed wires. If any of these conditions are present, discontinue use and replace immediately before continuing use.

### ⚠ WARNING

**Circuit breakers and fuses are meant to function as a safety measure that will disconnect power once the system becomes overloaded or compromised but will not offer complete protection from events such as voltage spikes or varying surges.**

### ⚠ WARNING

**Any breaker that is replaced must be replaced with that of the same amperage ratings and type as the one removed. NEVER use a higher rated replacement circuit breaker. Failure to follow this instruction may result in overloading the wiring system ultimately leading to overheating, damage to the RV, and/or fire.**



# SEC.11 ELECTRICAL SYSTEMS

## ⚠ WARNING

For 50 amp systems only: Ensure that the external power source is a 50 amp NEMA 14-50 RV receptacle and NOT a 240-volt AC receptacle.

## D. 120-VOLT AC SYSTEM

### 1. General Information

Your Brinkley RV fifth wheel is equipped with a 50 amp electrical service. This service is designed to operate on two (2) 120-volt power legs at a maximum flow of 50 amps/leg. When connecting to an external power source, the source must be a 50 amp service. When connecting to electrical service at a campground, the electrical service may occasionally experience spikes or drops in voltage.

## + NOTICE

Voltage spikes and drops can damage and/or shorten the service life of the electrical system and all the components it supplies power to.

The below electrical components will **ONLY** operate when the RV is connected to shore power or when operating the generator:

- Air conditioner.
- Converter.
- Various Receptacles.
- Fireplace.
- Water Heater.

For recommendations on power-surge protection and protectors, please contact your Dealer.

### 2. 120-Volt Circuit Breakers

All 120-volt AC circuit breakers are located within the load center that can be found in the lower cabinet of the kitchen hutch. These breakers function to protect 120-volt wiring and their supplied components. Each breaker found within the load center will be identified and labeled.



- If an overload or short circuit occurs, the corresponding breaker will trip causing the electrical flow to stop beyond the breaker itself.
- Once the breaker trips, allow time for the breaker to cool.
- To **RESET** the tripped circuit breaker, flip the breaker switch to the **OFF** position and then flip it back to the **ON** position.
- Contact your Authorized Dealer to diagnose and repair the electrical system if a given breaker immediately trips once it is reset or if it frequently trips in a short amount of time.

### 3. Maintenance and Replacement

Circuit breakers can wear out over time due to extensive use or exposure. Breakers should be inspected on an annual basis prior to the start of camping season. Replace breakers as needed but be sure they are replaced with the same rating and type that were originally installed.

#### **⚠ WARNING**

**To confirm the circuit breakers are operational, flip the breaker to the OFF position and then back to the ON position. As soon as you recognize unusual operation, discontinue use, and contact your Dealer for further testing and assistance. Failure to do so may result in damage to the RV, personal injury, or fire.**

### 4. Converter

The converter within the RV converts 120-volt AC power to usable 12-volt DC power once the RV is connected to an external power source via the shore power cord. This converter is located behind the load center and contains two 35 amp fuses to protect the converter from overheating. If overheating occurs, it is generally due to operating too many 12-volt systems at the same time for an extended period with little to no airflow.



To help prevent overheating from occurring:

- Do not utilize unnecessary 12-volt systems (i.e., lights, motors, appliances, etc.).
- Keep the cooling fan clear of any obstructions.
- Allow for proper ventilation in high temperature weather conditions.

### 5. Inspection and Maintenance

If the converter is not functioning or if the auxiliary battery is not charging when connected to shore power, it should be inspected.

#### **CONVERTER INSPECTION WHEN BATTERY DOES NOT CHARGE:**

1. Locate the converter (located in a front compartment behind an access panel).
2. Locate the two (2) 35 amp fuses on the converter.
3. Inspect and replace the fuses as needed.

For further assistance, please contact your Dealer.

#### **+ NOTICE**

Do not remove the converter from the RV or tamper with the housing. Doing so will void warranty. There are no serviceable parts within the converter that should ever be tampered with.

### 6. GFCI Receptacle

Ground wires help to stabilize current and offer a secondary path for electrical currents to travel in the case of exposure to a high voltage spike. This in return helps to prevent an electrical shock.



## SEC.11 ELECTRICAL SYSTEMS

Every Brinkley RV contains ground fault current interrupters (GFCI) designed specifically for the electrical system within your RV. GFCI's are designed to monitor the flow of electrical current between hot and neutral conductors and sense if an abnormality occurs. This circuit and device are designed with the intent to reduce possible injury caused by an electrical shock

### + NOTICE

A GFCI will not protect against circuit overloads or short circuits.

When a GFCI receptacle senses an abnormally high 120-volt current present through the grounding circuit, the GFCI will trip. This occurrence will generally happen when wires become wet inside an appliance, faulty wire insulation, a short within electrical equipment, etc.

### FREQUENTLY TEST GFCI RECEPTACLES.

#### TESTING A GFCI:

1. Push the TEST button on the receptacle. This should immediately pop the reset button which indicates the GFCI has been "tripped". Once tripped, no 120-volt power will flow through the receptacle.
2. Verify no power is present. This should be done with a receptacle tester (Customer Supplied).
3. Once you are sure no power is present, press the **RESET** button. This should restore the flow of 120-volt power.
4. Verify the presence of power with the same receptacle tester.
5. If the GFCI does not test properly or is defective, please contact your Dealer for assistance.

### E. 12-VOLT DC SYSTEM

Many RV components including the water pump, lights, motors, slide-out's, leveling, appliances, etc. operate on 12-volt electricity.

- The converter will convert 120-volt to 12-volt power when the RV is connected to external power. The converter also charges the auxiliary battery when the RV is connected to a power source.
- The auxiliary battery supplies 12-volt power to the RV when no external power is supplied but should not be used as the main electrical source.
- When towing, the alternator of the tow vehicle will supply 12-volt power if the 7-way wire harness is properly connected and the tow vehicle engine is operating.

The 12-volt power, from the 7-way, runs many of the key components needed for travel including brake lights, turn signals, running lights, and the breakaway switch. In addition to supplying power to these essential components, the 7-way wire harness will also provide a power source to charge the auxiliary battery within the RV.

#### 1. 12-Volt DC USB Ports

Within your RV you will find several 12-volt DC USB ports (i.e., in living room end tables, the sofa center console, some receptacles, etc.). When using these outlets, only use them on appliances and components that only require 12-volt and consumes less than 60 watts, or 5 amps. To prevent short circuits from occurring, keep all 12-volt USB ports free of any debris or foreign material.

#### 2. 12-Volt Fuse Panel

- Within the 12-volt fuse panels, labels will indicate the fuse locations, sizes, and component it powers. Never remove any of these labels.
- Inspect all fuses on a periodic basis, especially prior to camping season and replace as needed.



## + NOTICE

In the event of a power spike or surge, fuses may not offer complete protection for you or the RV.

### REPLACING FUSES:

**ALWAYS turn off or unplug components PRIOR TO replacing a fuse. This will help to protect the components within the RV.**

1. Before beginning, disconnect the shore power cord from the external power source.
2. Disconnect the negative terminal from the auxiliary battery within the RV.
3. Access the fuse panel and inspect fuses.
4. Remove the fuse by pulling straight back on the fuse from the fuse block.
5. Replace as needed.

Please contact your Dealer if the fuse is not blown and you are still experiencing electrical issues or if a circuit keeps blowing a fuse.

## ⚠ WARNING

**Never replace a fuse with one that contains a different amperage rating or another type other than the original. Failure to do so may result in personal injury, damage to the RV, or fire.**

### 3. Auxiliary Battery(ies)

Within the RV there are multiple 12-volt circuits. When all circuits are combined, the voltage load tends to be much greater than what the converter is capable of handling and auxiliary battery power is needed. For efficient sustainability, a 200Ah battery bank (2-100Ah batteries or 1-200Ah battery) has been installed in your RV. This is located in the front bulkhead storage compartment of the RV. To monitor the voltage of the battery bank, a battery monitor has been installed within the RV. See [Section 11\(4\)](#).

### 4. Dry Camping

Dry camping, also known as boondocking, involves camping in your RV with no electrical or water hook-ups. Prior to dry camping with your RV, make sure the battery bank is fully charged. If the components within the RV are strictly running off the power supplied by the battery bank, and the battery bank is not being charged by the generator (If Equipped) or solar, the battery bank will deplete in charge over time and will deplete at a faster rate the more power that you require. As an auxiliary battery becomes depleted and the charge lessens, it will discharge at a faster pace. It is highly recommended that you plan your electrical usage accordingly.

To ensure your battery is fully charged, test the auxiliary battery voltage using a volt-ohm meter. A fully charged 12-volt LiFePO4 battery will have a charging voltage of around 14.6-volts and a resting voltage of around 13.6-volts. Many LiFePO4 batteries can discharge 100% of their rated capacity every time with no ill effects. However, many manufacturers recommend discharging only 80% to maximize battery life.

The low-voltage cutoff of many 12-volt LiFePO4 batteries is around 10-volts. The battery monitoring system should detect when the battery voltage falls below 10-volts and enter a sleep mode to protect the battery cells from over discharge. Low-voltage cutoff is also called low-voltage disconnect, which you'll sometimes see abbreviated "LVD."

## SEC.11 ELECTRICAL SYSTEMS

### + NOTICE

Some batteries have higher cutoffs, such as 10.6-volts. Please be aware that the limit listed in the battery manual may not be exactly 10-volts.

Under normal conditions, the battery bank provides 200 amp-hours (Ah) of power. To determine the duration (in hours) of your battery power, take the battery amp-hour rating divided by the number of amps you are using. In [Section 11G](#), you will find the Amperage Chart for your RV that lists the normal amperages of the various components.

For example, if you are running the dinette lights (1 amps), the microwave (12 amps), and the water heater (12 amps) simultaneously, your battery power would last 8 hours.

$$200 \text{ Ah} / (1+12+12 \text{ amps}) = 8 \text{ hours}$$

**TOTAL BATTERY DURATION IN HOURS =  
(Battery Amp-Hour Rating)/(Components Ran)**

**In some cases, it is possible for the RV to drain the battery of the tow vehicle when the tow vehicle is not running, but is still connected through the 7-way plug to the RV.**

To prevent this from occurring, disconnect the 7-way plug when the tow vehicle is parked, and the engine is not running. Another way to prevent this from occurring is to install a Battery Isolator (Customer Supplied) on the tow vehicle. The Battery Isolator will act as a charging mechanism that will allow the tow vehicle to charge the battery within the tow vehicle itself as well as the RV battery while the tow vehicle engine is running.

### + NOTICE

It is very important NOT to discharge your tow vehicle battery below the level required to start the engine.

### 5. Maintenance/Replacement of 12V Equipment

Several components within the RV continuously draw battery power, even when the components are turned off (i.e., radio, TV, microwave, power tongue jacks, safety related equipment, etc.). The on-board memory of these components requires continuous power to save the memory. To prevent the auxiliary battery from being drained while not connected to shore power, utilize the master battery disconnect to fully disengage the battery. While the unit is in storage, it is best to remove the battery and place it on a battery maintainer. If you are unable to do so, it is suggested to check the voltage on the battery monthly and recharge as needed.

When purchasing a new battery or replacing an old battery, the amp hours, voltage, and type must be the same.

### ⚠ WARNING

**When replacing a battery, the amp hours, voltage, and type must be the same as the other installed. Failure to do so may result in damage to your electrical system, fire, personal injury, or death.**

For additional information or maintenance instructions, please contact the battery manufacturer for further assistance.

### + NOTICE

**NEVER** reverse the positive and negative terminals on the battery cables. Doing so will cause reverse polarity and blow the fuse protecting the converter.

## F. BATTERY DISCONNECT SWITCHES

You will find two (2) battery disconnects within the RV: the travel battery disconnect and the master battery disconnect.

**The travel battery disconnect** will prevent components from drawing power from the battery but will still allow any memory-based appliances to maintain memory, operation of the refrigerator, safety components (such as the CO alarm, brakes, running lights, etc.), solar charging and the front jacks to maintain enough battery draw to function. The travel battery disconnect is located in the pass-through storage compartment on the door side of the RV. Please see the photo below.



**The master, or main, battery disconnect** will disconnect all power to every component within the RV including those that are memory-based, or safety related. It kills power to everything. The master battery disconnect is in the front bulkhead (or firewall) storage area. Please see the below photo.



When auxiliary power is not needed for short term, the travel battery disconnect should be utilized.

- **TURN** the Battery Disconnect Switch from the **ON** position to the **OFF** position.
- The items listed above will remain operational.

When the RV will not be in use over an extended period of time or is placed in storage, the master, or main, battery disconnect should be utilized.

- **TURN** the Battery Disconnect Switch from the **ON** position to the **OFF** position.
- **ALL** power will be disconnected, and **NO** power will be supplied to any component including any 12-volt safety or memory-based items.

## G. CALCULATING ELECTRICAL LOAD

### 1. General Information

When connected to external shore power, the 120-volt AC system is capable of running a maximum of 100 amps momentarily and 50 amps on a continuous basis. If this rating is exceeded, the RV and/or electrical system of the campground may become overloaded, and as a result the main breaker will trip.

#### + NOTICE

DO NOT exceed the combined amount of 100 amps at any given time. To calculate the amps used, the draw of all components being utilized must be added together. To calculate an amperage rating for an appliance, take the wattage of the appliance divided by the voltage. Both the wattage and voltage should be listed on the appliance. For example: A 120-volt appliance rated at 1200 watts would utilize  $1200 \text{ watts} / 120\text{-volts} = 10 \text{ amps}$ .

# SEC.11 ELECTRICAL SYSTEMS

| 120 VOLT SYSTEM            |            | 12 VOLT SYSTEM              |            | 12 VOLT SYSTEM            |            |
|----------------------------|------------|-----------------------------|------------|---------------------------|------------|
| AIR CONDITIONER            | 14-18 AMPS | AISLE LIGHTS                | 0.5 AMPS   | LP DETECTOR               | 0,125 AMPS |
| COFFEE MAKER               | 6-12 AMPS  | BAGGAGE COMPARTMENT LIGHTS  | 0.5 AMPS   | PORCH LIGHT               | 1.5 AMPS   |
| CONVERTER (EACH)           | 8-11 AMPS  | DECORATIVE WALL LIGHTS      | 0.5 AMPS   | POWER AWNING              | 10 AMPS    |
| CURLING IRON OR HAIR DRYER | 10-14 AMPS | DINETTE LIGHT               | 0.5-1 AMPS | POWER VENT                | 5 AMPS     |
| MICROWAVE                  | 12 AMPS    | FANTASTIC (VENTILATION) FAN | 1.5 AMPS   | REFRIGERATOR              | 5.3 AMPS   |
| SATELLITE RECEIVER         | 2 AMPS     | 3" LED PUCK LIGHTS (EACH)   | 0.22 AMPS  | SHOWER LIGHT              | 0.22 AMPS  |
| TV                         | 2-4 AMPS   | FURNACE                     | 8-10 AMPS  | TV PLATE/ ANTENNA BOOSTER | 1 AMP      |
| VACUUM CLEANER             | 8 AMPS     | GENERATOR START             | 95 AMPS*   | VANITY LIGHT              | 0.22 AMPS  |
| WASHER/DRYER               | 12 AMPS    | ILLUMINATED SWITCH          | 0.125 AMPS | WATER HEATER              | 6 AMPS     |
| WATER HEATER               | 12 AMPS    | LEVELING SYSTEM             | 95 AMPS*   | WATER PUMP                | 7 AMPS     |

\*Momentary Load

## 2. Approximate Electrical Load Ratings

Please see the above amperage chart to obtain the amps used by each component.

## H. REPLACING LIGHT BULBS

Prior to replacing a light bulb, always make sure the light switch is turned off. This will prevent the flow of power to the light itself. Always make sure the light bulb is the appropriate size and type. If an incorrect bulb size is used, the electrical circuit can become overloaded causing the fixture to overheat and could cause a fire. Light bulb replacement is deemed Customer maintenance and are provided by the Customer. Light bulbs are not covered by any warranty.

## I. SOLAR POWER

A solar power system effectively charges the battery by converting solar energy to usable 12-volt power. As the battery becomes fully charged, the charge control system will protect the battery from overcharging by limiting the feed of solar power supplied. In your RV, the solar system provides power to all 12V system and to the

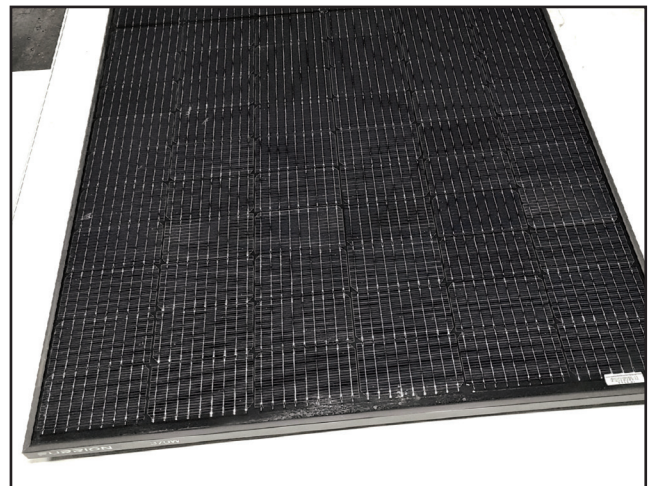

inverter. The inverter in return will permit operation of the GFCI 120V outlets, refrigerator, and air compressor.

Your Brinkley RV is equipped with a total of four (4) solar panels. Each solar panel is 200-watts and are installed on the roof of your Brinkley RV. These panels are wired in series and provide up to a total of 800-watts. Shown above is a photo of a standard 200W solar panel equipped on the roof of your Brinkley RV (location may vary by floorplan).



Additional details of the solar power system are provided below.

### 1. Solar Docking Port

The solar docking port inlet mounts directly on the roof of the RV and accepts the plug from the solar panel battery charger which enables you to charge your RV's 12V battery safely and quickly. The picture below left is a close-up view of the Solar Docking Port. The below right photo highlights the location of the Solar Docking Port relative to the solar panel. The photo to the right shows the Solar Docking Ports.

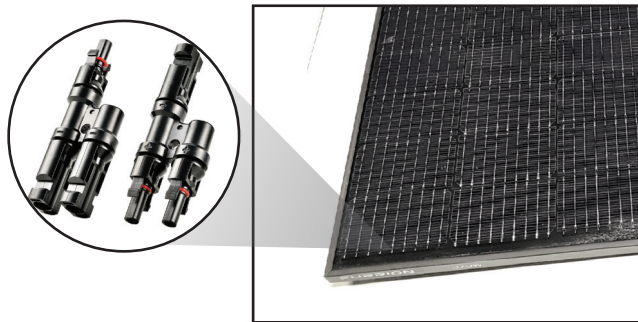

### 2. Solar Power Charging System

Your unit is also equipped with a 50 Amp Maximum Power Point Tracking (MPPT) Solar Charge Controller. The charge controller (shown below) checks the voltage output of the solar panel(s) and compares it to the battery voltage. It then converts the voltage from the solar panel(s) to obtain the maximum current into the battery to ensure the quickest and most efficient charging of the battery or batteries. The Charge Controller is located in the front bulkhead storage.

Prior to use, please read and understand the instructions and warnings found in the manufacturer's manual for the 50 Amp MPPT Solar Charge Controller and Solar Panel.



### + NOTICE

All safety alerts, warnings, and instructions should be followed when installing and/or using any Solar Power.

### 3. Inverter

The inverter installed within the RV is a Pure Sine Rich Solar 3000W Power Inverter. This inverter permits the operation of the GFCI 120V outlets, the refrigerator, and air compressor in the RV. The inverter can be found in the bulkhead storage of the RV. Please see the photo below.

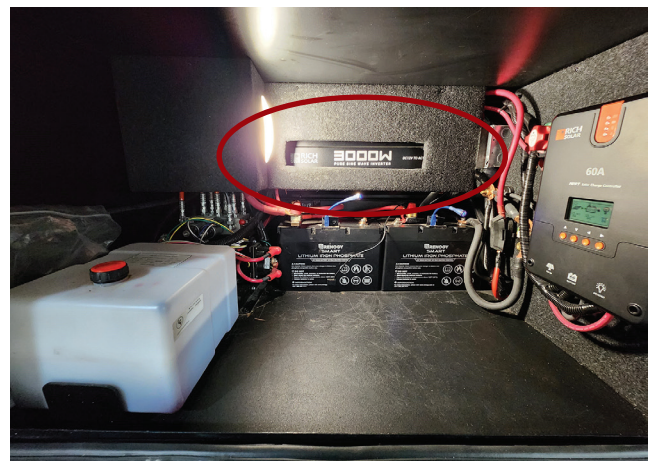

The purpose of this inverter is to invert 12-volt DC auxiliary battery power to usable 120-volt AC power for the RV. Power is inverted within two stages. Within the first stage, 12-volt DC power is amplified and converted to 300-volts DC. Within the second stage, the high voltage is converted into the needed watts (power) required to invert to 120-volts by using a form of transistor technology.

For additional information, warnings, and Instructions, please refer to the manufacturer's manual.

# SEC.11 ELECTRICAL SYSTEMS

## 4. Battery Monitor

A LiFePO4 Ion-Lithium battery has a rating capacity that is measured by amp-hours (Ah). For accurate readings, a battery tender is installed on the battery bank in your RV. This battery tenders continuously reads the charge of the battery bank and then relays the information to the battery monitor. The battery monitor in the G3500 is located in the master bedroom of the RV. This is shown in the photo to the right. Below is the display on the monitor.

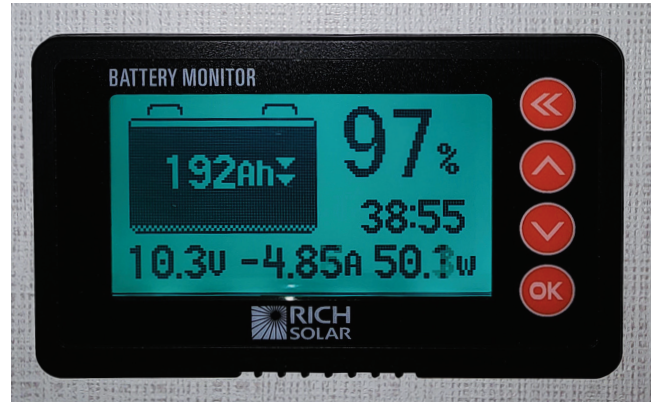

### NAVIGATION DISPLAY:

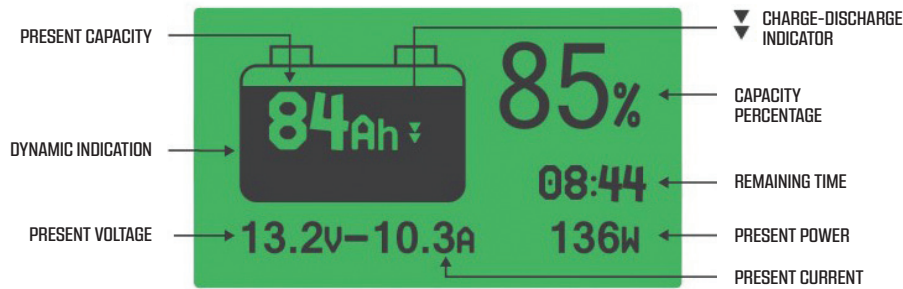

#### Present Capacity

is the capacity in amp-hours remaining within the battery bank.

#### Dynamic Indication

is a visual indicator of the capacity remaining within your battery bank.

#### Present Voltage

is the currently voltage of the battery bank.

#### Charge-Discharge Indicator

indicates whether the battery bank is increasing or decreasing in charge.

#### Capacity Percentage

is the capacity of the battery bank remaining.

#### Remaining Time

is the amount of usage time remaining if the usage remains the same.

#### Present Power

is the amount of power currently present measured in watts.

#### Present Current

is the amount of power currently present measured in amps.

## SPECIFICATIONS

|                      |            |  |                     |
|----------------------|------------|--|---------------------|
| WORKING VOLTAGE      | 8-120V     | ACCURACY OF CAPACITY COLLECTING              | (+/-) 1.0%          |
| WORKING DISSIPATION  | 10-15MA    | BACKLIGHT ON CURRENT (>50A SPECIFICATION)    | 100MA               |
| STAND-BY DISSIPATION | 1-2MA      | SETTING VALUE OF CAPACITY                    | 0.1-9999.0 AH       |
| CURRENT ACCURACY     | (+/-) 1.0% | TEMPERATURE RANGE IN APPLICATION ENVIRONMENT | 14-140°F (-10-60°C) |



### a. Detection/Setting of Battery Capacity

The battery(ies) effective capacity (CAP), also known as the amp-hours, needs to be programmed prior to the first use. As default, the monitor will set the CAP to 100Ah. The CAP is programmed at the factory, but in the circumstance it needs reprogrammed or the battery(ies) is replaced, the below steps should be taken.

#### PROGRAMMING YOUR BATTERY MONITOR:

1. Press and hold the “OK” button until the below screen is seen on the battery monitor.

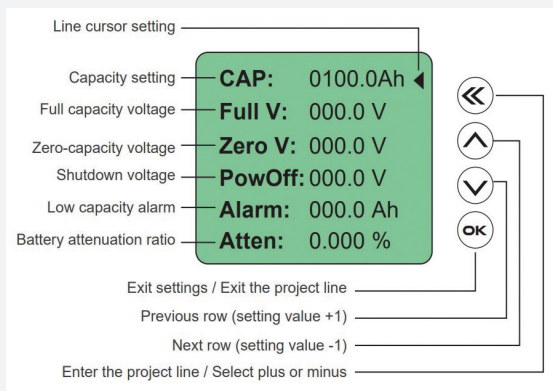

2. Press the up or down arrow until the cursor is beside the “CAP” setting.
3. Select the double arrow (<<) to enter on the project line.
4. Adjust the amp-hours by pressing the up or down arrows until you reach the correct setting.
5. Press “OK” to confirm the setting.
6. Repeat steps 2 through 5 to set-up the capacity voltage readings.

### b. Battery Voltage Alarm

As an additional feature, your battery monitor is also equipped with a battery voltage alarm. Once set, this alarm will notify you once your battery bank is depleted to the amp-hours you pre-selected. This alarm can be modified at any time and can be set when the monitor panel is displaying the setting screen.

#### PROGRAMMING THE ALARM:

1. Press and hold the “OK” button until the below screen is seen on the battery monitor.

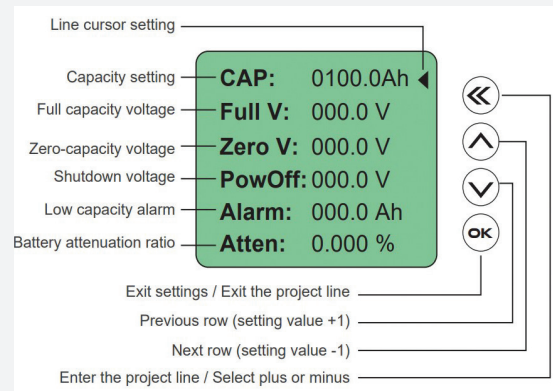

2. Press the up or down arrow until the cursor is beside the ALARM setting.
3. Select the double arrow (<<) to enter on the project line.
4. Adjust the amp-hours by pressing the up or down arrows to the desired amp-hours you would like to be notified at.
5. Press “OK” to confirm the setting.

#### + NOTICE

Once your battery bank is depleted to 10V, the battery monitoring system will automatically shut off to reserve power to protect the battery. This will occur even if an alarm is not set.

For additional information in regards to your battery monitoring system, please see the manufacturer’s manual located in the Owner’s Information Package.

# SEC.12 GENERATOR

## A. INTRODUCTION

The generator within your RV converts mechanical power, or fuel-based power, into usable 120-volt electrical power. This usable power will allow you to operate all 120-volt and 12-volt appliances and receipts while disconnected from shore power or while dry camping.

### 1. Safety Precautions

Prior to utilizing the generator within your RV, it is vital to understand the operational instructions and all safety related precautions. Please refer to the manufacturer's manual for this information.

- **NEVER** operate the generator in a confined space or within an enclosed building.
- **DO NOT** operate the generator if the exhaust is blocked, cracked, or incapable of dissipating the emissions.
- **DO NOT** operate the generator near tall or dry brush, grass, or other vegetation.
- **DO NOT** operate the generator when in close proximity to other objects, buildings, vehicles, snow walls, etc. that may block the generator's exhaust or become damaged by the heat.
- **DO NOT** operate in close proximity to open windows, tents, powered vents, etc. that may be exposed to the exhaust of the generator.
- **ALWAYS** allow the generator to cool prior to performing maintenance.
- **DO NOT** have an open flame or smoke near the generator while operating.

#### **⚠ WARNING**

**NEVER OPERATE THE GENERATOR WHEN SLEEPING.** Generators emit high levels of carbon monoxide when operating. While sleeping, you will unlikely notice emissions entering the RV if external factors abruptly change causing improper dissipation of exhaust fumes. Failure to recognize the presence of generator exhaust may lead to carbon monoxide poisoning or worse, death.

#### **⚠ WARNING**

**NEVER place or store flammable liquids or materials near or in the generator compartment. During operation, the generator will emit heat which may ignite anything flammable.**

#### **⚠ WARNING**

**DO NOT touch the generator while in operation or immediately after disengaging. Heat from the generator may cause burns. Prior to performing maintenance, ensure the generator has cooled to ambient temperature.**

#### **+ NOTICE**

The generator installed on your RV is not equipped with an inline conditioner or internal surge protector and is not intended to power sensitive electronics that may be utilized within your RV. Such electronics may include, but are not limited to, cellular devices, computers, printers, specific TVs, audio/video equipment, etc. Prior to powering any sensitive electronic, please contact your Dealer about an inline conditioner or filter (Customer Supplied).

### 2. Before Operating the Generator

Engine break-in on your generator is vital for peak performance. Proper generator break-in increases the performance of the engine while prolonging the life of the generator itself. For break-in instructions, please See [Section 12B\(1\)](#).

#### **Before operating the generator:**

- Verify the correct fuel source is selected and that fuel is available.
- Inspect for possible leaks on the fuel lines, LP lines, and exhaust.

- Inspect all generator components for damage or loose connections.
- Ensure all carbon monoxide detectors are properly functioning.
- Turn off any major component or power draw within the RV.
- Check the oil of the generator to ensure it is at the proper level.

### 3. Generator Control Panel Basics

The control panel for the 5500i model is located behind the maintenance access cover and is equipped with many features. These features are outlined within this section.

#### a. Push button start

Push and hold for 1 second to automatically start the engine and push again to stop.

#### b. Status indicator lights

##### - Low oil LED

This light indicates low oil level and will not allow the engine to start or run.

##### - Overload / Output ready LED

The 5500i model uses a single LED for these two functions. When this light is green, this indicates that the generator is ready to use. When this light is red, this indicates a general system electrical overload.

#### c. ON/OFF 20 Amp Output Circuit Breaker

The 5500i model uses two separate circuits as the AC output, a 20 amp circuit and a separate 30 amp circuit. The 20 amp circuit breaker automatically trips when the 20 amp circuit is overloaded to protect the generator and the appliance(s).

#### d. ON/OFF 30 Amp Output Circuit Breaker

The 30 amp circuit breaker automatically trips when the 30 amp circuit is overloaded to protect the generator and the appliance(s).

#### e. Reset button

If the generator is overloaded, the inverter will disconnect at the AC overload breaker. The engine will continue to run but there will be no electrical output. Reduce the electrical loads, then push the reset button, and then turn the breaker back to “ON.”

#### f. Gasoline Primer button

Press and hold the primer button to actuate the gasoline pump to bring fuel from the fuel tank to the generator engine. This is typically only needed the first time the generator is operated or after returning the generator to operation after being disconnected from the RV.

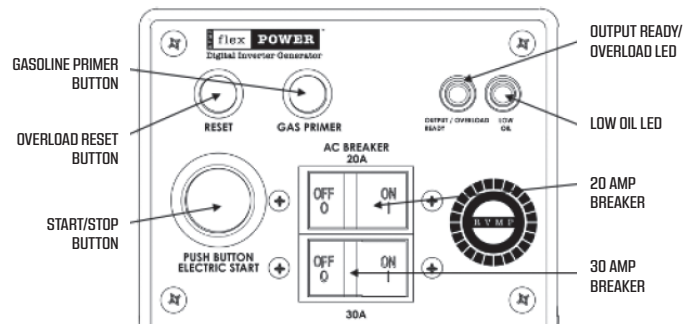

# SEC.12 GENERATOR

## 4. VFT Display

The VFT display can be used to indicate the following data. Press the mode button at the bottom of the display to cycle between the various data.

**Voltage (V)**—the output voltage of the generator.

**Frequency (F)**—the output frequency of the generator (Hz).

**Running time (R)**—the running time of the generator.

## 5. Remote Operation Panel

The generator installed on your RV can be operated by the control panel on the generator, the Brinkley OneControl touch panel, or OneControl App. The panel on the generator is equipped with the ability to start and stop the generator, prime the gasoline and read the VFT meter functions. The Install Manual shows the pin out for the wire harness exiting the generator and explains how to connect the generator to a remote panel. (available here: <https://rvmp.co/manuals>). If your RV does not have a remote operation control panel, you can purchase one from RVMP at [www.rvmp.com](http://www.rvmp.com). Once properly installed the below should be done.

- a. Press **START/STOP** to remotely start the generator and stop the generator.
- b. Press **PRIME** to prime the gasoline.
- c. (Other features may be available depending on the remote control being used).

## B. GENERATOR OPERATION

### 1. Breaking-In the New Engine

Proper engine break-in on a new generator is essential for top engine performance and acceptable oil consumption. Run the generator with no load for 30 minutes, then run the generator at approximately ½ power for the first two hours of operation, and ¾ power for two more hours. See electrical loading details in [Section 12B\(8\)](#) for

the generator to determine proper electrical loads. Proper engine oil and oil levels are especially critical during the break-in period. You should change the oil type if you will be operating the generator in extreme hot or cold climates.

**Check the oil level twice a day or every four hours during the first 25 hours of break-in, then change the engine oil after the first 25 hours.**

### 2. Pre-Start Checks

Before the first start of the day and after every eight hours of generator operation, inspect the generator as instructed by the manufacturer. Keep a running log of maintenance and the hours of operation and perform any and all maintenance that may be due.

### 3. Before Each Start

Prior to using the generator, it is very important to perform an inspection. Please see the following instructions.

#### BEFORE OPERATING/STARTING:

1. Verify that the correct fuel source is selected.
2. If turning the fuel switch to gasoline, make sure there is gasoline in the fuel tank.
3. If turning the fuel switch to LP, make sure the LP hose is safely and properly secured from the generator to the LP tank. Fully open the LP tank valve.
4. Make sure all vehicle carbon monoxide (CO) detectors are working.
5. Check for signs of fuel and exhaust leaks and for damage to the exhaust system.
6. Turn off the air conditioner and other large amp draw appliances.
7. Make sure the engine is filled with oil to the proper level.

#### 4. Starting the Generator

When gasoline is selected: If the generator is brand new, was recently serviced, or previously ran out of gasoline, prime the gasoline fuel system by pressing and holding the primer button on the control panel until all air bubbles have been purged out of the fuel hoses (this should only take a few seconds, do not prime for longer than this or you could flood the engine). When propane is selected, there is no need to press the primer button. The primer button is disconnected when operating on LP fuel.

#### + NOTICE

The generator can be started from either the OneControl Touch Panel, OneControl app, or directly at the front panel of the generator.

- a. Push and hold the start button for 3 seconds then release, the generator will begin an automated starting routine.
- b. The generator will stop cranking after a predetermined time. If the generator hasn't successfully started, it will likely make one or two more attempts to restart, without the need to press the start button again.
- c. Press and hold the start button again for 3 seconds to re-start the automated routine.

#### ⚠ WARNING

Operating the generator with the access door off can lead to severe burns. Always secure the access door after starting the generator.

#### ⚠ WARNING

Exhaust gases contain carbon monoxide (CO), an odorless colorless gas. Carbon monoxide poisoning can cause unconsciousness and death. Symptoms of carbon monoxide

poisoning include: dizziness, muscular twitching, weakness, sleepiness, throbbing in the temples, headache, inability to think clearly, nausea and vomiting. If you or anyone experiences any of these symptoms, move quickly to clean air outside of the RV. If symptoms persist, seek medical attention immediately. Shut down the generator and do not operate it until it has been inspected or repaired.

#### ⚠ WARNING

Never sleep in the RV with the generator running unless the RV is equipped with a working carbon monoxide detector. Primary prevention method against inhaling carbon monoxide is proper installation of the exhaust system and daily inspections for visible and or audible exhaust leaks.

1. Check for fuel and exhaust leaks. Stop the generator immediately if there is a fuel or exhaust leak and have it repaired before continued operation.
2. See Troubleshooting section below if the engine shuts down and any of the LEDs are blinking.
3. Secure the access door after starting the generator.

#### ⚠ WARNING

Short circuits in electrical appliances and tools can cause fire and electrical shock leading to severe personal injury and/or death. Read and follow the manufacturer's instructions and warnings regarding safe use, maintenance and proper grounding of the generator.



# SEC.12 GENERATOR

## 5. Resetting Overload

An electrical overload or a short circuit will trip the over-current protection system by disconnecting the generator's AC output at the AC circuit breaker(s) even though the generator engine continues to run. If this occurs, the OVERLOAD LED light on the generator control panel will illuminate red and the OUTPUT READY light will be off.

### TO RESTORE THE GENERATOR AC OUTPUT, USE THE FOLLOWING PROCEDURE:

1. Turn off all electrical appliances.
2. Press the red RESET button on the generator control panel until the OVERLOAD alarm light goes off and the OUTPUT READY light is on.
3. Check that the electrical starting and running loads do not exceed the generator's ampacity or have a licensed electrical/technician correct any fault causing a short circuit in the electrical wiring.
4. Turn on electrical loads as needed.

## 6. Stopping the Generator

During normal operation, press and hold the START button on the generator control panel for 1-3 seconds. The engine will automatically stop.

## 7. Connecting to Utility Power

### ⚠ WARNING

Connecting the generator to a public utility (or any other power supply) can lead to electrocution of personnel working on the utility lines, damage to equipment and fire. An approved switching device or transfer switch (If Equipped) must be used to prevent a dangerous connection.

When the RV is connected to utility power (shore power), such as a cord for plugging into a power receptacle at a campground, it must also have an approved switching/transfer device to keep the generator and utility from simultaneously supplying power to the RV.

## 8. Loading the Generator

The generator can power AC motors, air conditioners, AC/DC converters, charge batteries, and other appliances. The total appliance load that can be powered depends upon the generator's rated power for each model. The generator will disconnect AC output power at the AC breaker(s) on the front panel of the generator if the total sum of the loads exceeds the generator's rating.

To avoid overloading the generator and causing shutdowns, compare the sum of the RUNNING loads of the appliances that are likely to be used at one time to the power rating of the generator. Use the following diagram or the ratings of the appliances to obtain the individual appliance loads. It may be necessary to run fewer appliances at the same time. The sum of the appliance loads must not exceed the rating of the generator.

| HOME APPLIANCES      | RATED POWER (W) | STARTING POWER (W) |
|----------------------|-----------------|--------------------|
| FLAT SCREEN TV (27") | 80              | 100                |
| LOW-ENERGY LIGHT     | 5-50            | 5-50               |
| ELECTRIC COOKER      | 1000            | 1000               |
| COMPUTER             | 250             | 250                |
| ELECTRIC FAN         | 50              | 100                |
| WASHING MACHINE      | 250             | 500                |
| REFRIGERATOR         | 50              | 300                |
| AIR CONDITIONER      | 1600            | 3200               |

| TOOLS           | RATED POWER (W) | STARTING POWER (W) |
|-----------------|-----------------|--------------------|
| ELECTRIC HAMMER | 1000            | 1500               |

When a large motor (slide-out, leveling, etc.) or air conditioning unit is started, the generator may shut down due to overload even though the running power of the air conditioning unit is less than the rated power of the generator. This difference between the starting power and the rated power is due to the instantaneous amperage draw of the air conditioning unit when starting up and typically only lasts for a short duration. If the generator does shut down, allow 5 minutes to elapse before attempting to reconnect the generator to any load. Air conditioning units require time to equalize the pressure inside the air conditioning unit. Not allowing 5 minutes to elapse before reconnecting the generator is known as “short-cycling.”

It is also important to note that air density decreases as ambient temperature and elevation increases, which causes the generator’s output to decrease. Generator power decreases approximately 3.5% of rated power for each 1000 feet (304.8 m) above sea level. See the following diagram for typical calculations for the generator. It may be necessary to operate fewer appliances at higher elevations and increased temperatures.

| ELEVATION ABOVE MEAN SEA LEVEL | MAX. FLEXPWR 4000i GENERATOR POWER                | MAX. FLEXPWR 5500i GENERATOR POWER                |
|--------------------------------|---|---|
| UP TO 500 FT. (152 M)          | 4,000 WATTS (RATED)                               | 5,500 WATTS (RATED)                               |
| 2,500 FT. (762 M)              | 3,720 WATTS                                       | 5,115 WATTS                                       |
| 5,500 FT. (1,676 M)            | 3,300 WATTS                                       | 4,538 WATTS                                       |
| ABOVE 5,500 FT. (1,676 M)      | 3,300 WATTS MINUS 140 WATTS EA. 1,000 FT. (305 M) | 4,538 WATTS MINUS 193 WATTS EA. 1,000 FT. (305 M) |

#### + NOTICE

This table does not take into account the effect that circuit breakers may have in limiting maximum power.

## 9. Altitude Adjustment

As noted above, the generator performance will decrease at high elevations due to the reduced amount of oxygen available for combustion in the engine. To account for this, the carburetor contains an adjustment to improve performance at high altitudes. The generator comes from the factory with the altitude adjustment set for sea level.

1. To adjust the carburetor for high altitude operation, first determine elevation. Road maps, GPS, and road signs may provide this information.
2. Locate the high altitude adjustment knob shown in the below photo located on the carburetor bowl, it is located behind the air cleaner cover.



3. Rotate the knob to the local elevation.
4. Upon leaving high local elevation be sure to return the adjustment to lower elevations.

#### ⚠ CAUTION

Operating the generator at low altitudes with a high altitude setting can cause power loss, poor starting, overheating and engine damage. Always reset the high altitude adjustment when returning to lower altitudes.

## SEC.12 GENERATOR

### 10. Operating in Cold Weather

Pay particular attention to the following when operating the generator in cold weather.

1. Make sure the engine oil viscosity is appropriate for the ambient temperatures. Change the oil if there is a sudden drop in temperature.
2. Perform spark plug maintenance.
3. Perform starting battery maintenance.

For additional information, see the manufacturer's manual.

### 11. Operating in Hot Weather

Generators, similar to any engine system, need cool air while running. Flex Power generators are designed to manage airflow across all components to maintain a cool running temperature. Many factors go into the design of a generator to ensure proper airflow. Components like the enclosure, service door placement, base pan geometry, and blower wheel design play large roles in ensuring proper ventilation inside the generator.

The generator must be well ventilated to ensure proper operation. A well-designed ventilation path will:

- Provide combustion air that meets generator inlet air parameters.
- Remove heat dissipated by the alternator and engine.
- Limit recirculation of hot exhaust gases into the inlet air stream.

While the generator has been optimized for cooling internally, there is one key factor that cannot be controlled: the environment. The ambient temperature can play a big role in how the generator's cooling system performs. This environment includes both the immediate vicinity of the RV, as well as external factors.

RVMP or Flex Power cannot control where the RV goes or how the generator is used.

There are many local environmental effects that can affect the cooling performance of the generator, some of which the user can control, and some they cannot.

### 12. Hot Weather Operating Tips

Pay particular attention to the following when operating the generator in hot weather:

1. Pay attention to the generator airflow direction, and avoid impeding it – airflow can be greatly hindered by curbs and hills. Watch how close the generator is to the ground, and avoid placing camping equipment such as coolers or chairs under the generator.
2. Pay attention while leveling the RV as well, as sometimes this can cause the RV to sit lower to the ground or near something, blocking airflow.
3. Watch what is next to the RV as well; parking next to a wall or leaning something along the side of the RV can block necessary ventilation under the chassis of the RV, and prevent hot air from escaping.
4. Monitor how much dirt and debris the generator is kicking up while running. Picking up debris can block necessary airflow, in addition to clogging the air filter.
5. Wind direction can affect hot air from escaping the generator area. Orient the RV (when possible) to ensure that hot air is removed and cool air is continuously supplied.
6. Make sure the engine oil viscosity is appropriate for the ambient temperature.
7. Keep the generator clean.
8. Perform scheduled maintenance as recommended.

Remember that the generator needs space to breathe, and give it what you can to make sure this happens.

### 13. Hot Ambient Air

Generally speaking, a generator's rated power output will decrease as the ambient temperatures increase. As a general rule of thumb, a user can expect approximately 1% decrease in power for every 10° F (5.5° C) above 77° F (25° C). It is important for the user to recognize these limitations and the environmental challenges that the generator may have with cooling.

### 14. Ventilation

If the generator is not properly ventilated, it may overheat and affect its performance. Long periods of overheating may cause the generator to shut down and may ultimately damage the equipment. The generator draws cooling air from the top and sides of the unit while expelling hot air out of the bottom, see the image below.

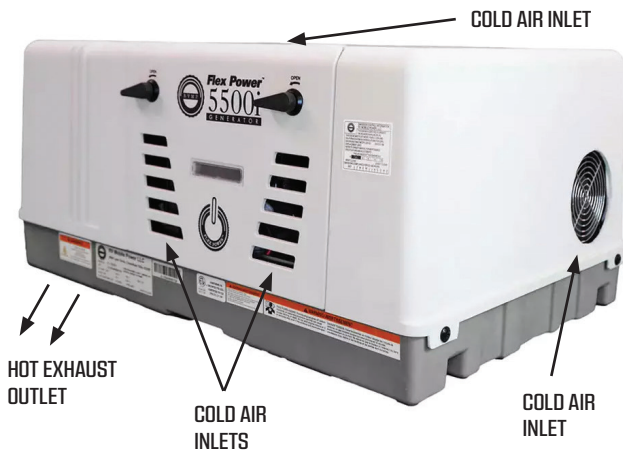

However, the cool air intake and hot air discharge have potential to recirculate hot air. Lack of intended paths for airflow, positioning of the generator, compartment spacing around the generator, and long skirting can cause hot exhaust to be ingested into the intake of the generator, an effect known as “hot air recirculation.”

### 15. Safe Temperature Operating Range

When running the generator on propane, do not run the generator in ambient temperatures lower than -0.4° F (-18° C) or higher than 120° F (49° C). When running the generator on gasoline, do not run the generator in ambient temperatures lower than -20.2° F (-29° C) or higher than 120° F (49° C).

The generator is designed to shut down when high ambient temperatures are experienced. This is to prevent damage to the generator and increase its lifetime. Once temperatures within the range below are experienced for a predetermined amount of time, the generator will automatically shut down and will need adequate time to cool before it can be restarted. The generator can be restarted once safely within the restart temperature range.

#### Shut Down Temperature Range:

241.7° F - 254.3° F (116.5° C - 123.5° C)

#### Restart Temperature Range:

220.1° F - 236.3° F (104.5° C - 113.5° C)

#### + NOTICE

If your generator shuts down due to high temperatures, you must consider the environment and climate and ensure there is proper airflow to the generator. The shut-down temperature is set very high for normal operating environments, but in some cases these high temps may be reached.

## 16. Operating in a Dusty Environment

Pay particular attention to the following items when operating the generator in dusty environments:

- a. Prevent dirt and debris from accumulating inside the generator compartment. Keep the generator clean.
- b. Perform air cleaner maintenance more often.
- c. Change the engine oil more often.
- d. Containers of engine oil that have been opened should be sealed tightly to keep out dust.

## C. GENERAL INSPECTIONS

Inspect the generator before the first start of the season and after every eight (8) hours of operation.

### **⚠ WARNING**

Exhaust gas is deadly. Do not operate the generator if there is an exhaust leak or any danger of exhaust gases entering or being drawn into the RV.

### **⚠ WARNING**

Do not park the RV in high grass or brush or any combustible materials that could cause a fire.

### 1. Exhaust System

- a. Make sure there is no debris blocking the exhaust pipe. If the RV has been stored for the winter, remove the plug from the tail pipe. Look and listen for exhaust system leaks while operating the generator. Shut the generator down if an exhaust leak has been found and have it repaired before continued operation.
- b. Look for openings or holes between the generator and the living compartment where exhaust gases could enter or if the generator sounds louder than usual, indicating a hole

in an exhaust tube that would allow gases to enter. Have an experienced service technician permanently seal any holes or other breaches. Replace dented or rusted exhaust components and make sure the tail pipe extends at least 1" (2.54 cm) beyond the perimeter of the RV.

- c. Park the RV so the generator exhaust gases can disperse away from the RV. Barriers such as walls, snow banks, high grasses and brush and other vehicles in close proximity can cause exhaust gases to accumulate in and around the RV. Do not operate power ventilators or exhaust fans while the vehicle is standing with the generator running. The ventilator or fan can draw exhaust gases into the vehicle.

### **⚠ WARNING**

Gasoline and LP are highly flammable and explosive and can cause severe personal injury or death. Shut down the generator and repair leaks immediately.

### 2. Fuel System

Check for fuel leaks at the hose, tube and pipe fittings while the generator is running and when it is stopped. Do not use a flame to check for fuel leaks. Check flexible fuel hoses for cuts and abrasions. Make sure the fuel hoses are not rubbing against other parts. Have a service technician replace worn or damaged fuel line components before leaks occur. If you smell the rotten eggs smell or LP, close the shut off valve on the LP tank immediately and have the generator and LP system serviced before continued use.

### 3. Battery System

Check the battery terminals for clean, tight connections. Loose or corroded connections have high electrical resistance which makes starting the generator more difficult.



#### 4. Mechanical Systems

- Look for mechanical damage. Start the generator and check for unusual noises and vibrations. Check generator mounting bolts or welded connections to the RV chassis to confirm they are secure.
- Check the generator air inlet and outlet openings are not clogged with debris or otherwise blocking airflow into or out of the generator.
- Clean accumulated dust, dirt or other debris from the generator. Do not clean the generator while it is running or still hot. Protect the generator, air filter, control panel, and electrical components from water, soap or cleaning solvents.
- Do not use a power washer to clean the generator.

#### 5. Checking Engine Oil Level

##### **WARNING**

Crankcase pressure can expel hot engine oil out of the fill opening, causing severe burns. Never attempt to check the oil level with the generator running.

##### **CAUTION**

Overfilling the engine with oil will increase the oil consumption and degrade engine performance. Keep the oil level within the cross hatched marks.

- Park the RV on a flat level surface.
- Unscrew the oil fill cap and wipe the oil off the dipstick. Screw the dipstick back in, remove it again and read the oil level on the cross hatched marks.
- Add or drain the oil as needed. Keep the oil level within the cross hatched marks.
- After checking the oil level, make sure the oil cap is screwed on securely.

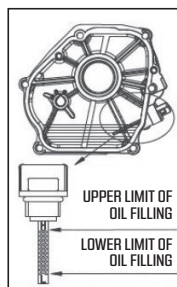

## D. TROUBLESHOOTING

### **WARNING**

Some generator service procedures present hazards that can result in severe personal injury or death. Only trained and experienced service personnel with the knowledge of fuels, electricity, and internal combustion engines should perform generator service.

The status indicator lights on the control panel alerts the owner to the status of the generator. See the panel below.



- The low oil LED will indicate the generator is low on oil. See [Section 12C\(5\)](#). If the generator doesn't start or continue to operate, check the status of the low oil level LED.
- The Overload LED indicates an over current condition as well as general overload conditions. This light will illuminate briefly when the generator is starting. If there is an over current condition, the generator will disconnect the electrical output but the engine will continue to operate.
- The Output Ready LED indicates that the generator is ready to be used. The light may flash while the generator is starting and will remain on during operation.

Please refer to the manufacturer's manual for additional information in regards to the generator.

# SEC.13 FUEL STATION

## A. INTRODUCTION

Your Brinkley RV comes equipped with a fuel station system. This system consists of two separate gasoline tanks, a fuel tank filler, gas pump, fuel gauge, control panel, and a fuel hose with nozzle.

The purpose of the fuel station system is to allow you to safely store gasoline for the use in ATVs, motorcycles, other vehicles, and any other equipment or need while traveling and camping with your RV.

When facing the fuel station, the tank closest to the front of the RV, or to the left, is the GENERATOR fuel tank and the tank closest to the rear of the RV, or to the right, is the ACCESSORY tank. Two tanks are installed so that different fuel types can be stored. The generator fuel tank is plumbed directly to the generator and the accessory tank has a fuel nozzle to dispense fuel as needed. If desired, the fuel in the accessory tank can be dumped into the generator tank using the fuel nozzle of the accessory fuel tank.



## B. GENERAL SAFETY

It is vital to be cautious of your surroundings when utilizing the fuel station. Below are some safety guidelines that should be followed.

- ALWAYS turn off all vehicle engines, generators, along with any fuel sourced appliance (i.e. furnace, cooktop, water heater, etc.).
- ALWAYS turn off the main valve to the LP.

- NEVER smoke or light any flame when operating the fuel station or when using the gasoline.
- NEVER run any combustion engine longer than needed within a confined space (i.e. closed garage).
- NEVER use the provided fuel for anything beyond its intended use.
- NEVER prop the fueling latch on the dispenser in the OPEN position.
- ALWAYS connect the bonding jumper to help eliminate static electricity. This will help to eliminate the possibility of a static fire.
- NEVER overfill the vehicle or equipment fuel tank. This may cause undesired spillage.
- NEVER allow children under the licensed driving age to operate the fuel station.
- ALWAYS minimize exposure to gasoline fumes and the inhalation of the fumes.
- NEVER attempt to siphon the fuel by mouth. Gasoline is very harmful and can be fatal if swallowed.
- ALWAYS keep fuel away from skin, mouth, or eye contact. If fuel comes in contact with any surface on your body, immediately rinse the area with water.
- ALWAYS remove any fuel-soaked clothing immediately after use.

### **⚠ WARNING**

Before dispensing fuel you should always:

1. Turn all engines and fuel source appliances OFF (this should include any ignitors).
2. Connect the bonding jumper wire to the equipment or vehicle receiving fuel.
3. Ensure the RV is properly Grounded.

**DO NOT dispense fuel when within 20 feet (6 m) of an ignition source or within 10 feet (3 m) of another motor vehicle or RV. Failure to follow these instructions may result in fire, damage, serious injury, or death.**

**⚠ WARNING**

Gasoline is only to be used for its intended use. It is not to be used to wash your hands or as a cleaning solvent. Using gasoline in this manner may result in damage, bodily harm, or worse.

**⚠ WARNING**

Never smoke or operate an open flame when using the fuel system. Failure to comply may result in serious injury or death.

**C. FILLING THE FUEL TANKS**

The fuel tanks on your RV will need to be individually filled, one at a time. As a reminder, the fuel tank to the left, closest to the front of the RV, is the GENERATOR fuel tank and the tank to the right, closest to the rear of the RV, is the ACCESSORY fuel tank.

**FILLING THE FUEL TANK:**

1. Carefully remove the fuel cap. Opening the cap too quickly can cause fuel to spray out as the pressure is released. The hotter the ambient temperature, the more likely pressure is to build behind the cap.



2. Select the octane grade desired for the tank you are filling.
3. Insert the gas pump's fuel nozzle into the inlet of the RV fuel tank and begin filling.
4. Do not continue to fill once the gas station's pump stops. Overfilling the RV fuel tank may lead to leaks or damage to the fuel system.
5. Reinstall the fuel cap.
6. Make sure all spillage is cleaned up prior to closing the compartment and leaving the gas station.

**D. DISPENSING FUEL**

In order to dispense fuel, the fuel pump will need to be engaged. This can be performed by pressing the ON button found at the tank monitor. Please see the instructions below for proper operation.

**+ NOTICE**

Fuel cannot efficiently be dispensed if the tank is under a third (1/3) of the way full and the last 10% of the fuel remaining in the tank cannot be consumed.



## SEC.13 FUEL STATION

### DISPENSING FUEL:

1. Ground the RV by connecting the RV to the tow vehicle or by lowering the leveling system to the ground. Properly grounding the RV reduces the possibility of static discharge while fueling an external fuel tank.
2. Turn OFF all fuel fed appliances, generators and engines along with anything that may attempt to ignite.
3. Close ALL vents in the garage area of the RV to prevent fuel vapors from entering the RV.



4. Locate the fuel switch found at the fuel station control panel. If the panel is in Sleep/Locked mode, press either the ON or OFF button. To unlock the panel press and hold the OFF button until the ON feature begins to blink.

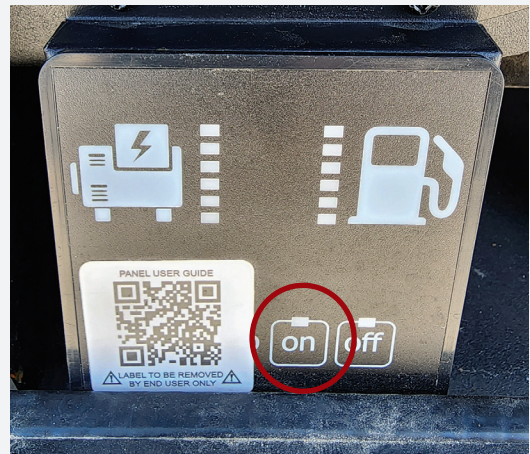

5. Turn the fuel pump ON. The pump will run for 5 minutes before it cycles OFF. This is a safety feature of the fuel pump. If you are still fueling after 5 minutes, the fuel pump switch will need to be turned ON once more. Continue this cycle until fueling is complete.
6. Locate the fuel hose and nozzle located in the fuel station compartment. Place the tip of the nozzle into the opening of the fuel tank.



7. Begin filling by squeezing the trigger on the fuel nozzle. Be careful not to overfill the vehicle's or equipment's fuel tank. If spillage occurs, clean the area immediately.



8. Once the tank is full, release the fuel handle, return the nozzle to the compartment, and turn OFF the fuel pump switch. Once you turn the pump off, you will hear the pump operate in reverse. This is to empty any remaining fuel found in the hose or dispensing nozzle.

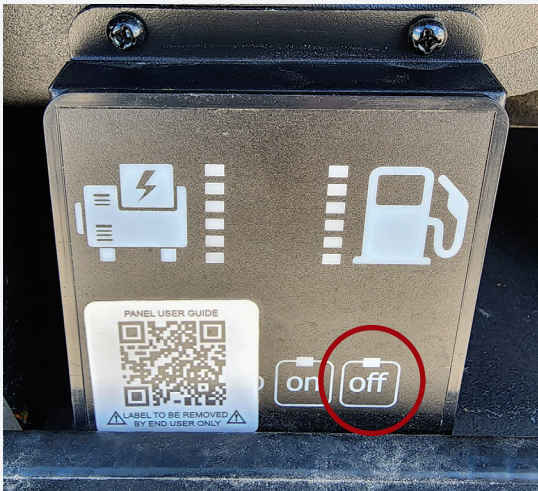

9. After 2 minutes of inactivity, the fuel station control panel will return to the locked mode.

**⚠ WARNING**

If fuel spillage occurs within the RV, properly ventilate the RV and clean the area with paper towel or cloth. Make sure the cleaning material used is properly disposed of immediately after in a hazardous waste container. any material becomes flammable with the presence of fuel.

Do not place cleaning rags with fuel on them within the RV, other vehicle, or any other area that may be a source of flame.

Failure to adhere to this warning may result to damage to your RV, personal injury, or death.



# SEC.14 AUDIO & VIDEO

## A. INTRODUCTION—AUDIO & VIDEO

Within this section you will find information pertaining to the original audio and video components installed in your RV at the Brinkley RV factory. For additional information, please refer to the manufacturer’s manuals found in the Owner Information Package or visit their website. In the circumstance where an aftermarket modification or installation has been performed on your RV, please contact the servicing Dealer who performed the aftermarket modification or installation work for additional information.

## B. AUDIO—ROCKFORD FOSGATE® SOUND SYSTEM

The Brinkley Model G is equipped with an amazing sound system. You could be a mobile DJ with the quality of the sound system provided. It is absolutely one of the best sounding stereo systems in the market.

### ⚠ CAUTION

**PRACTICE SAFE SOUND** - Continuous exposure to sound pressure levels over 100dB may cause permanent hearing loss. High powered auto sound systems may produce sound pressure levels well over 130dB. Use common sense and practice safe sound.

### 1. Features of the Wired Remote (“Source Units”)—Punch PMX-1R

Your unit is equipped with wired remotes that provides the various functions and operations of the Rockford Fosgate Sound System. Please refer to the diagram (below) for the buttons schematic.

### 2. Locations of the Punch PMX-1R Remotes

Your RV is equipped with multiple remotes that permit you to operate the stereo system from different locations in the RV. The locations of the remotes will vary from floorplan to floorplan. As an example, the Model G3500 is equipped with remotes in the following locations:

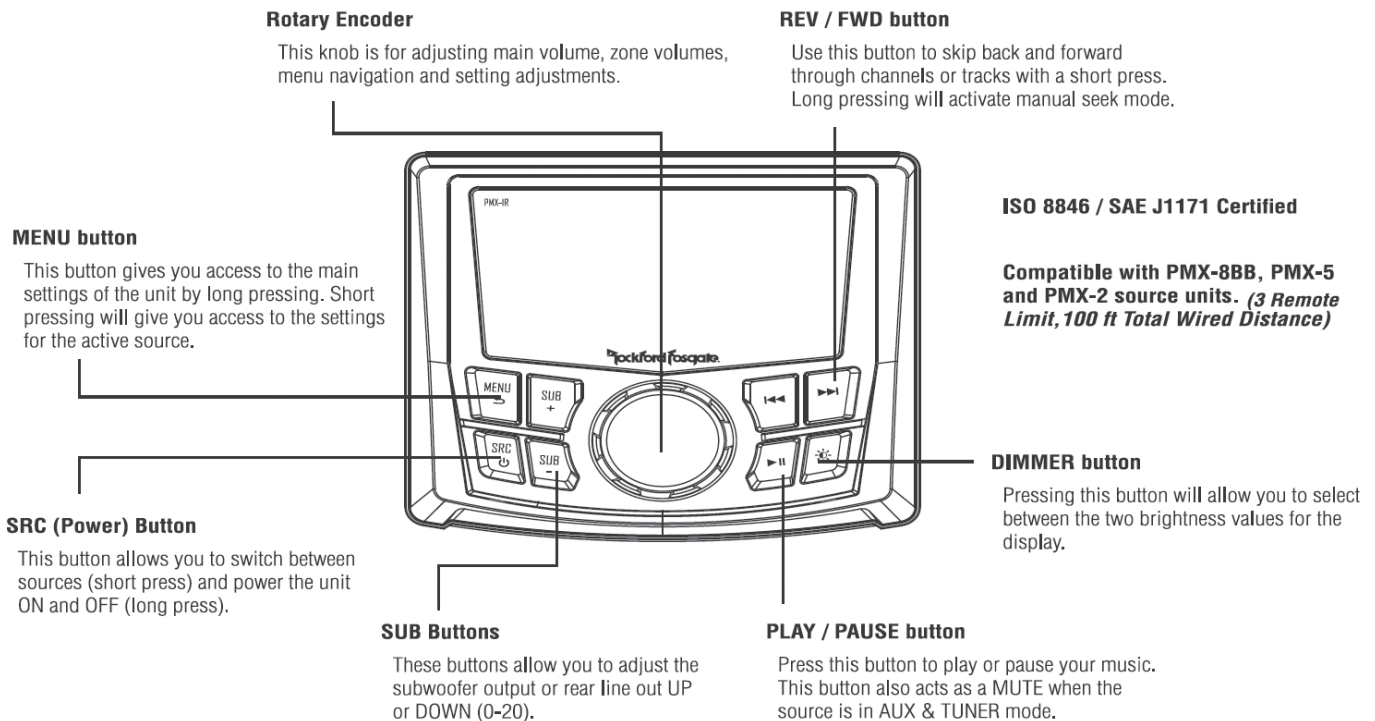

### a. Main Living Room—Entertainment Center

The first location is located above the fireplace in the living room (see picture below):



### b. Door Side Pass—Through Storage

The second location of the wired remote is the door side pass-through of the RV (as shown below):



### c. Garage

The third remote is located in the garage area. In the G3500, it is located in the wall that separates the main living area from the garage of the RV:



### 3. PMX-1R Remote—Features

#### a. Source Unit Settings

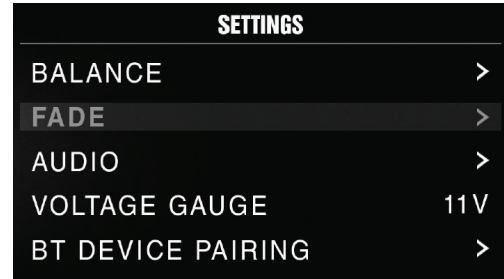

To access the source unit's settings, long press the MENU button until the options appear. Rotate the encoder wheel to scroll through the list of settings and short press the encoder button to select the setting you wish to change. Here is the list of options: **ZONES > BALANCE > FADER > AUDIO > VOLTAGE GAUGE > BT DEVICE PAIRING > BEEP > TUNER REGION > SOFTWARE > PMXCAN > FACTORY DEFAULT.**

#### + NOTICE

This source unit has a zero current draw when turned off. All of your settings and presets will be saved utilizing your RV's battery during storage.

#### b. Zones

At Brinkley, your Model G audio system is set up in 4 zones:

1. Exterior;
2. Interior—main living area;
3. Interior—garage; and
4. Exterior—patio.

You are able to select any of these 4 zones either simultaneously or individually depending on what areas of the RV you want the audio to play within. If you would like to change or edit zones, please refer to the instructions on the next page.

### (i) Setting Up Zones

To setup ZONE 1, 2, 3 or 4, short press the encoder button or press the ZONE button to access the submenu. Rotate the encoder button to select the ZONE options. **SOURCE > RENAME > ENABLE/DISABLE/LOCK**

#### + NOTICE

During regular listening, long press the encoder button to switch between zones.

### (ii) Changing/Selecting the Source

To select the source, short press the encoder button to access the SOURCE submenu. Use the rotary encoder to scroll through SOURCE Settings. **FM TUNER > AM TUNER > WB TUNER > USB > AUX1 > AUX2 > BLUETOOTH > PANDORA > SiriusXM > CAMERA**

### (iii) Renaming the Zones

To rename a ZONE, short press the encoder button to set the first letter of the new name. Once active, rotate encoder to adjust letters. Short press the encoder button again to set the next letter. Repeat until ZONE has been renamed. Short press MENU to exit and go back up one level.

### (iv) Enable/Disable/Lock

Short press the encoder button to access. Rotate the encoder button to select ENABLE/DISABLE/LOCK. Selecting LOCK will enable ZONE 2 and LOCK the source of ZONE 2 to ZONE 1.

### c. Balance

Short press the encoder button to access BALANCE adjustment settings. Rotate the encoder button to set the output BALANCE.

### d. Fader

Short press the encoder button to access FADER adjustment settings. Rotate the encoder button to set the output FADER.

### e. Audio

To access the AUDIO settings, short press the

AUDIO option from the MENU screen.

Rotate the encoder to scroll through the list of settings and short press the encoder button to select the setting you wish to change.

**7 BAND EQ > CROSSOVER > PEQ > REAR RCA > AUX1 INPUT > AUX2 INPUT > SOURCE GAIN > INTERNAL AMPLIFIER**

### (i) 7 Band EQ

Short press the encoder button to access the 7 BAND EQ settings. Use the rotary encoder to scroll through the EQ settings. **FLAT > ROCK > CLASSIC > ACOUSTIC > DANCE > ELECTRONIC > HIP-HOP > CUSTOM**. When setting up the CUSTOM EQ, short press the encoder button to set the first frequency. Once active, rotate the encoder to adjust the frequency settings. Short press encoder button again to access the next frequency. Repeat until all EQ settings are complete. Short press the MENU button to exit and go back up one level.

### (ii) Crossover

Short press to access the CROSSOVER settings. Use the rotary encoder to select the crossover zone options (HPF > LPF). The HPF setting is for FRONT + REAR audio and LPF is for SUB audio. Short press the encoder to adjust the frequency of the crossover (60Hz > 80Hz > 120Hz > APF). Short press MENU to exit and go back up one level.

### (iii) Punch EQ

Short press to access the PUNCH EQ settings. Use the rotary encoder to adjust the gain output (0-12). Short press MENU to exit and go back up one level. Punch EQ is an onboard equalizer with up to +6dB @45Hz and/or up to +6dB boost at 12.5kHz.

### (iv) AUX1/AUX2 Input

#### (a) Rename

To rename AUX1 or AUX2, short press the encoder button to set the first letter of the new name. Once active, rotate the encoder to adjust letters. Short press the encoder button again to set the next letter. Repeat until AUX has been renamed. Short press MENU to exit and go back up one level.

**(b) Enable**

Short press the encoder button to access options. Rotate the encoder button to select if the unit is discoverable. **ENABLE > DISABLE**

**(v) Source Gain**

To adjust the level of the device input gain, scroll through the inputs **FM TUNER > AM TUNER > WB TUNER > USB > AUX1 > AUX2 > BLUETOOTH > PANDORA > SiriusXM** to the device you want to adjust and short press the encoder button to access the gain settings. Rotate the encoder button to set the level of gain. (-3dB > -2dB > -1dB > 0dB > +1dB > +2dB > +3dB)

**(vi) Internal Amplifier**

Short press to access the INTERNAL AMPLIFIER options. Use the rotary encoder to select the options (ON > OFF). When using an amplifier to power your speakers, select OFF. If you are powering your speakers directly from the source unit, select the INTERNAL AMPLIFIER to ON.

**+ NOTICE**

Since the Model G sound system has external amplification, the internal amplifier should be set to OFF for optimal sound performance.

**f. Voltage Gauge**

To display the vehicle voltage, short press the encoder button on the VOLTAGE GAUGE option.

**g. Bluetooth (BT) Device Pairing**

Short press the encoder button to access options. **DISCOVERABLE > DEVICE**

**(i) Discoverable**

Rotate the encoder button to select if unit is discoverable for pairing. (**ENABLE > DISABLE**) Once enabled, the source unit is now discoverable and ready for pairing to your device. Open the Bluetooth settings on your device to find the source unit labeled “**Rockford PMX**” and select.

**(ii) Device**

Selecting DEVICE by short pressing the encoder button will allow you to rename the source unit with up to 16 characters. This gives you the ability to have a unique name for easy identification during device pairing. Short press the encoder button to select the letter to be changed and rotate the knob to change the value. Repeat the process until desired name is reached.

**h. Beep**

Short press the encoder button to access the BEEP options. Rotate the encoder button to turn system beep ON/OFF.

**i. Turner Region**

To adjust, short press the encoder button to access. Rotate the encoder button to select the TUNER REGION of your preference. **EUROPE > USA > RUSSIA > LATIN > ASIA > JAPAN > MIDEAST > AUSTRALIA**

**j. Software**

**(a) Version**

Short press the encoder button to display the current firmware version of the unit.

**(b) Update**

Short press the encoder button to update the firmware. Follow the instructions on the screen when updating.

**k. Theme**

To adjust the THEME, short press the encoder to access the feature. Rotate the encoder button to select the desired Bold Text. **DAY > NIGHT > AUTO**

**I. PMX-CAN Diagnostic Status**

Short press the encoder button to display the connection status.

**(i) Model Number**

Short press the encoder button to display the connect CAN model.



### (ii) Version

Short press the encoder button to access the HARDWARE, FIRMWARE and NMEA2000 software versions.

### (iii) NMEA2000 Code

Short press the encoder button to view the MFG, PRODUCT and CLASS codes.

### (iv) NMEA Instance

Short press the encoder button to access the NMEA200 INSTANCE settings and change INSTANCE settings.

#### + NOTICE

The purpose of NMEA is to give equipment users the ability to mix and match hardware and software. NMEA-formatted GPS data also makes life easier for software developers to write software for a wide variety of GPS receivers instead of having to write a custom interface for each GPS receiver. As such, the NMEA settings are not applicable for towable RV use.

### m. FACTORY DEFAULT

#### (i) AUDIO

Short press the encoder button to access. Rotate the encoder button to select YES/NO. Selecting YES will reset your unit back to factory default settings.

#### (ii) SYSTEM

Short press the encoder button to access. Rotate the encoder button to select YES/NO. Selecting YES will reset your unit back to factory default settings.

#### + NOTICE

Resetting the SYSTEM settings will also reset any SiriusXM user data.

### 4. Basic Operation of the Sound System

#### a. Turning the unit ON/OFF

Long press the SRC (Power) button to turn the unit ON or OFF.

#### b. Adjusting the Volume

Short press the encoder button to independently adjust the volume for a specific zone (**ZONE ALL > ZONE1 > ZONE2 > ZONE3 > ZONE4**). Rotate encoder knob left or right to desired volume level (0-40). The current volume level will be displayed during adjustment.

#### c. Adjusting the Subwoofer Output

Press the SUB + or SUB - buttons to adjust the output level (0-20).

#### d. Adjusting the Screen Brightness–Dimer

Short press the SCREEN BRIGHTNESS button to adjust the brightness level. There are two brightness levels.

#### e. Selecting a Source to Play

Short press the SRC button to show the different source options (**FM TUNER > AM TUNER > WB TUNER > USB > AUX1 > AUX2 > BLUETOOTH > PANDORA > SiriusXM > CAMERA**). Use the rotary encoder or short press the SRC button to scroll through sources.

#### f. Selecting a Zone

Long press the encoder button to toggle between source zones (**ZONE 1 > ZONE 2 > ZONE 3 > ZONE 4**).

### 5. Tuner Operation (FM/AM/WB)

To operate, use the rotary encoder to select the tuner source you want to listen to (**FM > AM > WB**). To AUTO SEEK stations, short press the FWD and REV buttons. To MANUAL SEEK stations, long press the FWD and REV buttons to tune to the desired frequency.

To MUTE the TUNER, short press the PLAY/PAUSE button.



### a. FM Band Settings

To access the FM BAND SETTINGS, short press the MENU when using the FM TUNER source. This will give you access to the settings specific to the FM TUNER (**PRESETS > ADD PRESETS > REMOVE PRESETS > FM > AUTO STORE > LOCAL > RBDS**).

### b. Presets

Short press the encoder button to access the PRESETS list. Using this feature allows you to see what PRESETS are saved on the unit.

### c. Add Presets

Short press the encoder button on the ADD PRESETS option. You will need to be on both the station and PRESET group you want to add first (**FM1 > FM2 > FM3**). Using this feature allows you to save stations to the unit. Once selected, use the rotary encoder to select the PRESET number (1-6) you want the station saved to.

### d. Remove Presets

Short press the encoder button on the REMOVE PRESETS option. You will need to be under the PRESET group you want to adjust first (**FM1 > FM2 > FM3**). Using this feature allows you to remove saved stations on the unit. Once selected, use the rotary encoder to select the PRESET number (1-6) of the station you want removed.

### e. FM Band Settings

Short press the encoder button to access the FM PRESET options (**FM1 > FM2 > FM3**). Using this feature allows you to have separate tuner preset groups to choose from. Use the rotary encoder button to scroll through the TUNER groups and short press to select the group.

#### (i) Auto Store

Short press the encoder button to access the AUTO STORE function. You will need to be under the PRESET group you want to adjust first (**FM1 > FM2 > FM3**). This feature automatically stores presets on the unit. It will stop when presets 1-6 are set. Select the next PRESET group and repeat to fill next set.

#### (ii) Local

Short press the encoder button to access the LOCAL options. Once selected, use the rotary encoder to select ON or OFF. The local option tunes to nearby radio stations with sufficiently strong signals for good reception. In areas where reception is poor, switching to distance tuning enables the unit to tune in to more distant stations. Distance tuning is the default.

### f. AM Band Setting

To access the AM BAND SETTINGS, short press the MENU when using the AM TUNER source. This will give you access to the settings specific to the AM TUNER (**PRESETS > ADD PRESETS > REMOVE PRESETS > AM > AUTO STORE > LOCAL**).

#### (i) Presets

Short press the encoder button to access the PRESETS list. Using this feature allows you to see what PRESETS are saved on the unit.

#### (ii) Add Presets

Short press the encoder button on the ADD PRESETS option. You will need to be on both the station and PRESET group you want to add first (**AM1 > AM2**). Using this feature allows you to save stations to the unit. Once selected, use the rotary encoder to select the PRESET number (1-6) you want the station saved to.

#### (iii) Remove Presets

Short press the encoder button on the REMOVE PRESETS option. You will need to be under the PRESET group you want to adjust first (**AM1 > AM2**). Using this feature allows you to remove saved stations on the unit. Once selected, use the rotary encoder to select the PRESET number (1-6) of the station you want removed.

#### (iv) AM

Short press the encoder button to access the FM PRESET options (**AM1 > AM2**). Using this feature allows you to have separate tuner preset groups to choose from. Use the rotary encoder button to scroll through the TUNER groups and short press to select the group.

## (v) Auto Store

Short press the encoder button to access the AUTO STORE function. You will need to be under the PRESET group you want to adjust first (**AM1>AM2**). This feature automatically stores presets on the unit. It will stop when presets 1-6 are set. Select the next PRESET group and repeat to fill next set.

## (vi) Local

Short press the encoder button to access the LOCAL options. Once selected, use the rotary encoder to select ON or OFF. The local option tunes to nearby radio stations with sufficiently strong signals for good reception. In areas where reception is poor, switching to distance tuning enables the unit to tune in to more distant stations. Distance tuning is the default.

## g. Weather Band (WB) Settings

To access the WB BAND SETTINGS, short press the MENU when using the WB TUNER source. This will give you access to the settings specific to the WB TUNER (**PRESETS>ADD PRESETS >REMOVE PRESETS**).

### (i) Presets

Short press the encoder button to access the PRESETS list. Using this feature allows you to see what PRESETS are saved on the unit.

### (ii) Add Presets

Short press the encoder button on the ADD PRESETS option. You will need to be on both the station you want to add first. Using this feature allows you to save stations to the unit. Once selected, use the rotary encoder to select the PRESET number (1-6) you want the station saved to.

### (iii) Remove Presets

Short press the encoder button on the REMOVE PRESETS option. Using this feature allows you to remove saved stations on the unit. Once selected, use the rotary encoder to select the PRESET number (1-6) of the station you want removed.

## h. USB (iPOD) Operation

After your device is connected to the source unit, this feature allows you to control playback from your device directly from the unit. Select the USB source option on the source unit.

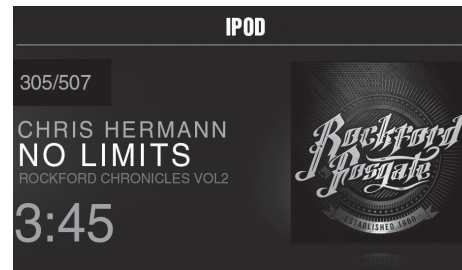

To play or pause a song, short press the PLAY/ PAUSE button. To skip a track forward, short press the FWD button. To skip a track backwards, short press the REV button. To access USB specific settings, short press the MENU button for the list of settings (**BROWSER > REPEAT > SHUFFLE**). Use the encoder to select the option to change.

### (i) Browser

Short press the encoder button to access the BROWSER options (**PLAYLISTS > ARTISTS > ALBUMS > GENRES > SONGS > COMPOSERS > AUDIOBOOKS > PODCASTS**). Using this feature allows you to search for tracks or songs by different types of categories.

### (ii) Repeat

Short press the encoder button to access the REPEAT feature options (**OFF > ONE > ALL**).

### (iii) Shuffle

Short press the encoder button to access the SHUFFLE feature options (**OFF > ALL**). This feature allows you to set your preference on shuffling tracks or songs.

## + NOTICE

When using a USB extension cable, it must be a Rockford Fosgate powered extension cable. The maximum distance for the cable is 33 feet (10 meters).

### i. AUX1/AUX2 Operation

After your device is plugged into the source unit, this feature allows you to play music from your device. Use the rotary encoder to select the AUX1 or AUX2 source option on the source unit and use your plugged in device to control song/track selection, PLAY/PAUSE and track skip FWD/REV.

### j. Bluetooth Operation

After your device is paired to the source unit, this feature allows you to control playback from your device directly from the unit. Select the BLUETOOTH source option on the source unit.

To play or pause a song, short press the PLAY/PAUSE button.

To skip a track forward, short press the FWD button.  
To skip a track backwards, short press the REV button.

To access BLUETOOTH specific settings, short press the MENU button for the list of settings (**BROWSER > REPEAT > SHUFFLE**). Use the encoder to select the option to change.

#### (i) Browser

Short press the encoder button to access the BROWSER options (**PLAYLISTS > ARTISTS > ALBUMS > GENRES > SONGS > COMPOSERS > AUDIOBOOKS > PODCASTS**). Using this feature allows you to search for tracks or songs by different types of categories.

#### (ii) Repeat

Short press the encoder button to access the REPEAT feature options (**OFF > ONE > ALL**). This feature allows you to set your preference on the amount of times a track or song will repeat.

#### (iii) Shuffle

Short press the encoder button to access the SHUFFLE feature options (**OFF > ALL**). This feature allows you to set your preference on shuffling tracks or songs.

### k. Pandora

This feature allows you to control Pandora® from the source unit (Android: Bluetooth use only, iOS: both USB and Bluetooth use). You will need to start the

Pandora® app on your device first, then select the Pandora® source option on the source unit. To use the “Thumbs Up” feature, long press the SUB+ button. To use the “Thumbs down” feature, long press the SUB button.

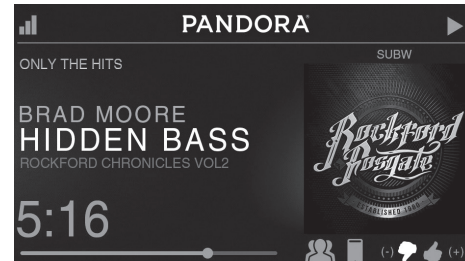

To play or pause a song, short press the PLAY/PAUSE button.

To skip a track forward, short press the FWD button.

To access Pandora® specific settings, short press the MENU button for the list of settings (**STATIONS > BOOKMARKS > STATIONS MANAGE**). Use the encoder to select the option to change.

#### (i) Stations

To adjust, short press the encoder button to access. Rotate the encoder button to select your options (**SHUFFLE > SORT DATE/A-Z > STATIONS**). Selecting the SHUFFLE option will shuffle your stations and selecting the SORT feature will sort your stations by date added or alphabetically. You can also select your saved stations directly from this list.

#### (ii) Bookmarks

To BOOKMARK an artist or track that is playing, short press the encoder button to display your BOOKMARK options (**ARTIST > TRACK**). Select the option you wish to use for bookmarking.

#### (iii) Station Manage

To create stations, short press the encoder button to display your STATION MANAGE options (**CREATE FROM ARTIST > CREATE FROM TRACK > CREATE FROM GENRE > DELETE**). Selecting the CREATE FROM ARTIST OPTION allows you to create a station from the artist that you are currently listening to.

## SEC.14 AUDIO & VIDEO

CREATE FROM TRACK works similarly by creating a station from the current track being played. If you create a station by selecting CREATE FROM GENRE, this will give you music genres to select from to create your station. Selecting DELETE will delete the now playing station.

*Pandora, the Pandora logo, and the Pandora trade dress are trademarks or registered trademarks of Pandora Media, Inc. Used with permission. Pandora is only available in certain countries. Please visit <http://www.pandora.com/legal> for more information.*

### I. Sirius XM®

Only SiriusXM® brings you more of what you love to listen to, all in one place. Get over 140 channels, including commercial-free music plus the best sports, news, talk, comedy and entertainment. Welcome to the world of satellite radio. A SiriusXM Connect Tuner and Subscription are required. For more information, visit [www.siriusxm.com](http://www.siriusxm.com).

#### (i) Activating your SiriusXM Subscription

After installing your SiriusXM Connect Tuner and antenna (sold separately), power on your source unit and select SiriusXM mode. You should be able to hear the SiriusXM Preview channel on Channel 1. If you cannot hear the preview channels, please check the installation instructions to make sure your SiriusXM Connect tuner is properly installed. After you can hear the Preview channel, tune to Channel 0 to find the Radio ID of your tuner. In addition, the Radio ID is located on the bottom of the SiriusXM Connect Tuner and its packaging. You will need this number to activate your subscription. Write the number down for reference.

#### + NOTICE

The SiriusXM Radio ID does not include the letters I, O, S or F.

In the USA, you can activate online or by calling SiriusXM Listener care:

- Visit [www.siriusxm.com/activatenow](http://www.siriusxm.com/activatenow).
- Call SiriusXM Listener Care at 1-866-635-2349.
- For Canadian Subscriptions, please contact:

- Visit [www.siriusxm.ca/activatexm](http://www.siriusxm.ca/activatexm).
- Call XM Customer Care at 1-877-438-9677.

As part of the activation process, the SiriusXM satellites will send an activation message to your tuner. When your radio detects that the tuner has received the activation message, your radio will display: "Subscription Updated". Once subscribed, you can tune to channels in your subscription plan.

#### + NOTICE

The activation process usually takes 10 to 15 minutes, but may take up to an hour. Your radio will need to be powered on and receiving the SiriusXM signal to receive the activation message.

#### (ii) Settings

To access the SiriusXM SETTINGS, short press the MENU when using the SiriusXM source. This will give you access to the settings specific to SiriusXM. (**SXM > PRESETS > ADD PRESETS > REMOVE PRESETS > CHANNELS > CATEGORY**)

#### (a) SiriusXM Preset Bands (SXM)

Short press the encoder button to access the SiriusXM PRESET options (**SXM1 > SXM2 > SXM3**). Using this feature allows you to have separate satellite preset groups to choose from. Use the FWD and REV buttons to scroll through the TUNER groups.

#### (b) Presets

Short press the encoder button to access the PRESETS list. Using this feature allows you to see what PRESETS are saved on the unit.

#### (c) Add Presets

Short press the encoder button on the ADD PRESETS option. You will need to be on both the channel and PRESET group you want to add first (**SXM1 > SXM2 > SXM3**). Using this feature allows you to save channels to the unit. Once selected, use the rotary encoder to select the PRESET number (1-6) you want the channel saved to.

**(d) Remove Presets**

Short press the encoder button on the REMOVE PRESETS option. You will need to be under the PRESET group you want to adjust first (**SXM1 > SXM2 > SXM3**). Using this feature allows you to remove saved channels on the unit. Once selected, use the rotary encoder to select the PRESET number (1-6) of the channel you want removed.

**(e) Channel**

Short press the encoder button on the CHANNEL option to select this feature. This feature displays a complete listing of channels.

**(f) Category**

Short press the encoder button on the CATEGORY option to select this feature. This feature allows you to search channels based on their CATEGORY type.

**(g) Direct Tuning**

Short press the encoder button on the DIRECT TUNING option to select this feature. This feature allows you to directly tune to a channel if you already know the channel number. Rotate the encoder until you reach the desired number **I** and press to enter your selection. Repeat until the channel number is completed.

**(h) Parental Controls**

Short press the encoder button on the PARENTAL CONTROL option to select this feature. This feature allows you to easily lock and unlock channels with mature content. To turn this feature on, short press the encoder on PARENTAL CONTROLS to select. You will be asked to enter a code to activate it. **Enter “1111” for your code.** Once the code is entered correctly, this will give you access to the PARENTAL CONTROL features (**LOCK CHANNELS > CHANGE MY CODE**). Use the encoder knob to scroll through the options and short press to select.

**(i) Lock Channels**

Short press the encoder button on the LOCK CHANNELS option to select this feature.

This feature allows you to select certain channels to be locked out for listening. When trying to listen to locked channels, you will need to enter the correct code to listen to them. Use the rotary encoder to input code.

**(j) Change my Code**

Short press the encoder button on the CHANGE MY CODE option to reset the PARENTAL CONTROL code. Use the rotary encoder to input the code.

**j. Troubleshooting**

To access the Rockford Fosgate Troubleshooting Guides, please refer to your Owner’s Information Packet and locate the manual entitled “PUNCH Hide-Away Media Receiver”. The troubleshooting information is located starting on page 14 of that manual.

**C. AUDIO/VISUAL SYSTEMS—TELEVISIONS**

**1. TV Operation—Main Living Area**

- a. Turn on the power to the TV.
- b. Select the signal input using the “source” selection on the remote.
- c. Adjust the TV Antenna/Channel Tuning until service is found.

See the TV Roof Antenna manual and TV manual for further instructions.

**+ NOTICE**

The TV within the RV is a smart TV. Various streaming platforms are available when connected to Wi-Fi or cellular data.

**⚠ CAUTION**

**When connecting or disconnecting the antenna and power supply cables to the TV, make sure the power is turned off. When testing for voltage, turn the TV on.**



## 2. TV Reception Basics

TV signal transmission is a point-to-point communication system. Any obstructions between the transmitter and the antenna will weaken the signal and ultimately affect the picture quality. Local TV stations transmit their broadcast signal “over the air.” Antennas are designed to receive the local broadcast signal and display the image on the TV screen. Picture and sound quality depend on the type of antenna, the distance from the transmission, and the surrounding environment of the RV. The signal will weaken the further your antenna is from the source and the more obstructions in the path of the signal.

## 3. TV Signal Booster

To improve antenna reception, the TV Signal Booster must be turned ON.

- The TV Signal Booster works by amplifying all signals to improve the quality of the signal received by the TV.
- To turn the TV Signal Booster on or off, you must locate the antenna connection plate located in the main bedroom, behind the TV, in the ceiling. The button to turn the TV Signal Booster on and off is labeled “ANT POWER.” It is shown in the picture below.



- When viewing cable, satellite, watching a DVD, or playing a gaming system, the TV signal booster must be turned off. The signal booster signal can be picked up by the devices listed above and can cause issues with picture quality.

## + NOTICE

There is also an on and off button located to the right of the coax connection. This button is to turn the Wi-Fi on and off.

## 4. Cable/Satellite Outlet

Cable and Satellite connection outlets can be located within the water convenience center in the pass-through compartment. The picture below shows the location of the connections circled in red.



- The Cable input is transmitted through an RG6 coax cable that contains an in-line splitter that will allow the cable to be connected to multiple locations.
- The Satellite input is transmitted through an RG6 coax cable but DOES NOT contain an in-line splitter and is directly ran to each specific location within the RV. This allows for an uninterrupted transfer of HD signal from the satellite dish to the TV. For satellite, each TV must have a receiver at the TV for the satellite to function.

## Winegard AIR 360+ Operation

- AIR 360+ can receive VHF/UHF/FM frequencies while in a parked position from any direction up to 55 miles away.



### Connecting COAX for Cable and Satellite:

1. For cable, connect the threaded coax from the source to the “CABLE” connection.
2. For satellite, connect the threaded coax from the satellite dish to the “SAT” connection.

Please refer to the satellite manufacturer’s manual for information, instructions, care, and maintenance instructions.

#### + NOTICE

A satellite dish is not provided with your RV and is purchased aftermarket.

### 5. TV Roof Antenna

To watch local TV stations, turn the TV and TV Roof Antenna power on.

- The antenna has 360 degrees of reception so there is no need to aim or point the antenna in the direction of the signal.
- The antenna is also internet ready and easily connects to the Winegard Gateway router for Wi-Fi, 5G and GPS. See [Section 9B\(7\)](#) for additional details.



**ANTENNA POWER  
SUPPLY**

#### + NOTICE

If you are considering adding the Winegard Gateway router, please note that many of its features overlap with those of the TraviFi system. Please consult with your Dealer prior to making this decision. For information on the Gateway Wi-Fi Router, please See [Section 15D](#).

- You must run a Channel Scan on your TV to receive maximum programming.
- Ensure the antenna power supply is in the “ON” position and the green indicator light is illuminated. See [Section 14C\(3\)](#) above for details. It is located behind the bedroom TV.
- A secondary scan can locate and add any new channels found in your area as well as any channels that have been moved or changed.

While the steps to perform a channel scan may vary between televisions or compatible devices, below are some general guidelines to follow:

#### HOW TO RUN A CHANNEL SCAN USING THE TV REMOTE:

1. Select “**Menu**” then select “**Settings**.”
2. Select “**Channel Setup**.”
3. Select “**Antenna**” or “**Air**,” depending on your TV. Make sure you are not on “**Cable**.”
4. Select “**Channel Search**” or “**Channel Scan**.”
  - a. The steps to perform a channel scan may vary.
  - b. If the wording on your TV differs from the options shown, refer to your TV user manual for help.
  - c. Running a Channel Scan is NOT the same as pressing Channel UP/DOWN on your remote.
5. To keep your saved channels up to date, it is recommended to run a Channel Scan:
  - a. Once per month;
  - b. When a channel is lost; or
  - c. When you change locations.

## + NOTICE

The exact locations of local broadcasting towers can be found at: [www.fcc.gov/reports-research/maps/dtv-maps/](http://www.fcc.gov/reports-research/maps/dtv-maps/).

### 6. Vision S Camera System

The Furrion Vision S Camera System is a standard component installed on your Brinkley fifth wheel. This system includes a back-up camera, two side marker light cameras, and a 7" viewing monitor.



#### THE FURRION VISION S CAMERA

This camera system is wired to only have power when the RV is connected to the tow vehicle via the 7-way towing connector. The Furrion Vision S Camera System offers a 65 or 120 degree viewing angle, night vision, motion detection, blind spot signal, and auto wake function for extra security when the RV is stationary. Most importantly, it is provided to help you safely transport and back-up your unit. Please read both the manual for the Furrion Vision S Camera System and the Lippert OneControl manual found in your Owner Information Package prior to downloading or using the Lippert OneControl App and Furrion camera. You can also locate the Furrion Vision S camera owner's manual online at: [https://cdn.accentuate.io/6110841962679/5237057552473/IM-FCM00007\\_V3.0\\_EN-v1635233414650.pdf](https://cdn.accentuate.io/6110841962679/5237057552473/IM-FCM00007_V3.0_EN-v1635233414650.pdf).

## A. GENERAL INFORMATION

Your RV is equipped with the TravlFi JourneyXTR Router. This is a multi-functional wireless 4G LTE Cat.7 CPE router, providing 4G LTE Internet with both physical and virtual SIM card. The TravlFi JourneyXTR Router can support up to 1200Mbps Wireless with Dual-Band Wi-Fi 2.4GHz & 5GHz. With an embedded 4G LTE Cat.7 chipset, it works well with all the mainstream frequency bands for 4G LTE up to 300Mbps.

In this section, you will find an overview of the various components found on the JourneyXTR router, basic hardware installation, and first login information. It is highly recommended that you acquaint yourself with the Quick Start Guide before using the device.

## + NOTICE

To get started, you will need to select a data plan through TravlFi. To do so, please visit [travlf.com/plans](http://travlf.com/plans).

## B. CONNECTING TO TRAVLFI

Once a data plan has been selected, you will need to activate your JourneyXTR router.

### CONNECTING YOUR JOURNEYXTR TO TRAVLFI:

1. Locate your router and ensure all six antennas are properly seated in the LTE/WI-FI ports. The router is located above the cabinet in the kitchen area. Antennas labeled 2.4 GHz are in the 2.4 GHz ports, and the antennas labeled 5 GHz are in the 5 GHz ports. The router and the external antennas should look like the image (top right).

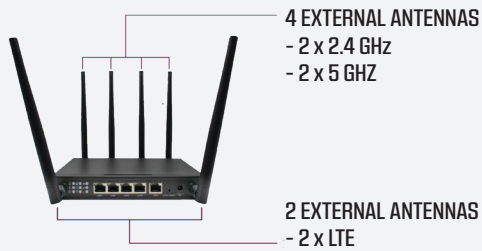

2. Make sure the device has power. From the factory, this router is connected to power, but some Dealers may elect to disconnect the router while the RV is on display.
3. Call 1-800-960-6934 or scan the QR code below to activate your JourneyXTR router with a TravlFi Pay As You Go data plan of your choice.



4. After activation, search for either of the 2.4 Ghz or 5 Ghz Wi-Fi frequencies that match the SSID located on the bottom of the unit. Use the Wi-Fi Key, also located on the bottom of the device unit, as your password.

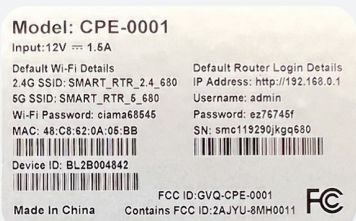

### + NOTICE

After startup, the device may need a few minutes to find the best cellular signal available in your area. Once this process is complete, internet/data connection will automatically function over Wi-Fi and LAN.

## C. WI-FI EXTENDER MODE WITH TRAVLFI

In addition to utilizing the JourneyXTR to provide Wi-Fi via cellular networks, you can also configure it to connect to a local Wi-Fi network by updating the settings to “Universal Repeater Mode.” Below are instructions on how to change the mode.

### Wi-Fi Extender Mode

1. Ensure you are connected to the TravlFi Router. Then, open your device’s web browser.
2. Go to the web address: <http://192.168.0.1>.
3. Type in the administrative username and password, then proceed to Login.  
Default username: admin  
Default password: admin
4. Select the “Settings” icon:



5. To connect the TravlFi router to a Wi-Fi Network, under Settings, select the “Wi-Fi” button.
6. Determine if the desired Wi-Fi network is 5 GHz or 2.4 GHz and select the appropriate frequency under “WLAN interface”.
7. Select the checkbox next to: “Enable Universal Repeater Mode”.

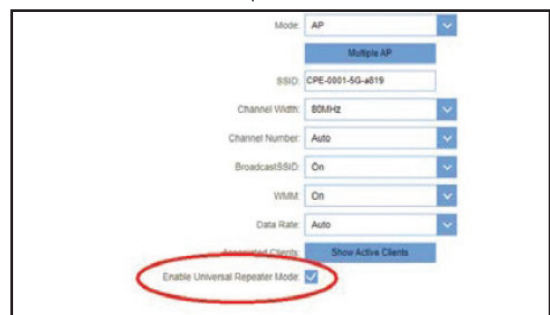



# SEC.15 CONNECTIVITY

8. Select “Save and Apply” to continue.  
The router will now re-configure to allow Wi-Fi repeating.
9. Upon returning to the administrative interface, select “Settings” and then select “Wi-Fi”.
10. Then select “Site Survey” and press the “Site Survey” button to perform a scan of local Wi-Fi networks.
11. Select the network of your choice and press the “Next” button.

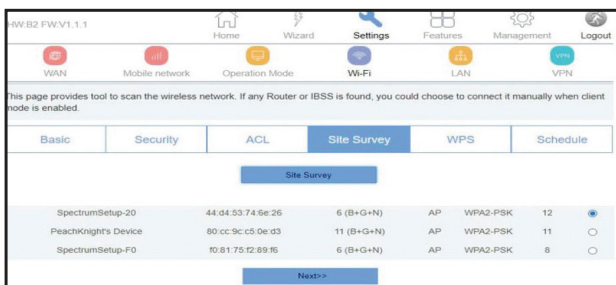

12. Enter in the password credentials for the new Wi-Fi network and then press the “Connect” button:

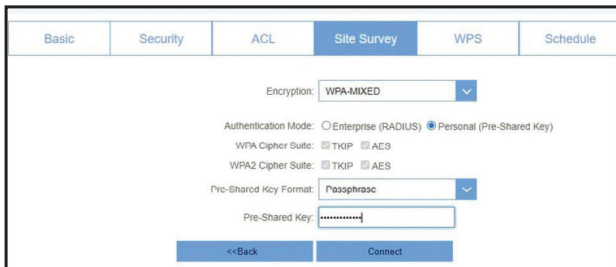

Wait for the router to connect to the new Wi-Fi network.

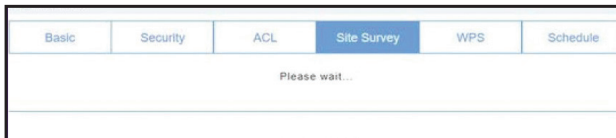

If successful.

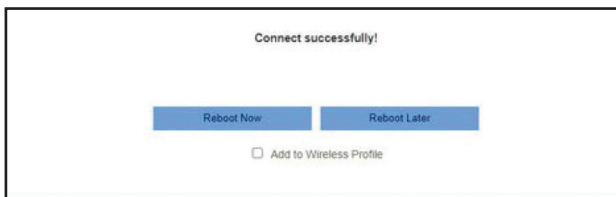

13. Press the “Reboot Now” button to reboot the router and connect to the Wi-Fi network upon restart. Reboot later may also be chosen, but the router will not connect immediately.

## + NOTICE

After the router reboots, you may need to reload the webpage and log back into the router.

14. Upon returning to the administrative interface, select “Settings” and “Operation Mode”.

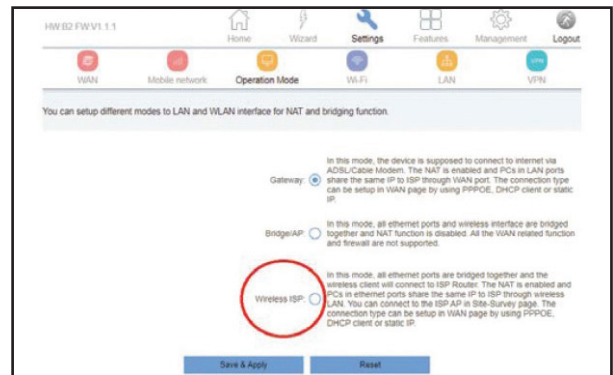

## + NOTICE

The default operational mode is “Gateway”.

15. Select “Wireless ISP”. This will bring up a “WAN Interface” subsection.

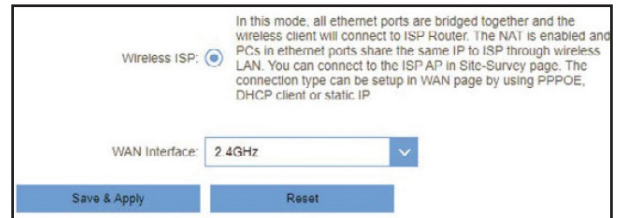



16. Select the WAN interface (Wi-Fi frequency) of your choice:

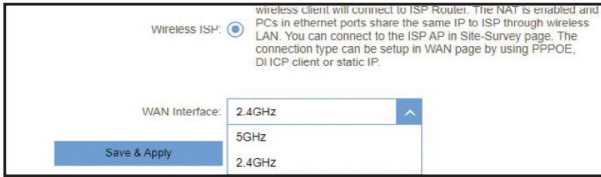

17. Select “Save & Apply” and the TravlFi router will automatically reset:

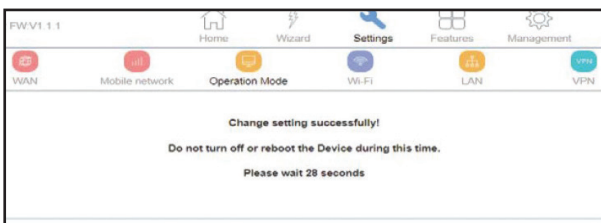

18. Select the Home icon at the top of the screen and select “IPv4”.

The “Connection Type” should now read “Wi-Fi Repeater” and current Wi-Fi network connection should be listed under “Connect AP”:

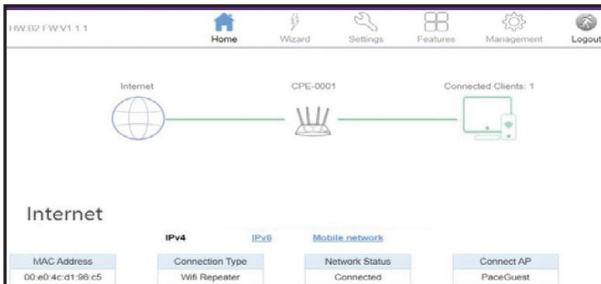

If you happen to have any further questions or concerns about TravlFi, please call 1-800-960-6934 or scan TravlFi’s QR code below to learn more.



## D. WINEGARD GATEWAY WI-FI ROUTER (Customer Supplied)

As an alternative to TravlFi and the supplied JourneyXTR Router, a Winegard Gateway 5G LTE Wi-Fi Router (GW-1000) is an optional upgrade to the AIR 360+ antenna installed on the RV. This router provides GPS and activates the pre-installed 5G LTE and Wi-Fi antennas in your AIR 360+. Adding this upgrade provides you with an all-in-one solution for your internet, TV and AM/FM radio. The RV is prepped for this upgrade, but this an aftermarket purchase and is to be Customer Supplied.



For additional information or details, please contact your Dealer or visit [winegard.com/gateway](http://winegard.com/gateway).

## A. USING YOUR RV'S ONECONTROL SYSTEM

Your Brinkley Model G is equipped with a OneControl® Smart RV System. OneControl provides access to awnings, slides, lights, resource levels and more from displays in the RV and in the OneControl App.

When you pair the OneControl App with your RV, you have access to all OneControl devices on your RV through your app. It also provides access to App-only features like Auto Set-up™, Vehicle Health Monitor™ and a Checklist Builder designed for RVing.

You may customize your system with smart accessories like liquid propane sensors, fridge and freezer temperature sensors and keyless door locks. After pairing with your App, these can be added to display devices in the OneControl app on your RV.

This manual will provide you with an overview of the OneControl System. For deep-dives on devices like leveling, please consult their specific manuals or their corresponding section in this manual.

## B. DEVICE ACCESS

You may operate devices on the OneControl System from the touch pad located inside the RV as well as from the app.

### Touch Panel

The OneControl Touch Panel™ (OCTP) provides access to all devices from inside your RV. The OCTP is located near the front door.

### Monitor Panel

The OneControl Monitor Panel™ provides access to a subset of frequently used devices inside your RV. It's mounted in the rear of the RV.

## Mobile App

The OneControl App provides access to all RV devices. The App is available through the Apple® or Android™ App Stores. After downloading and creating your account, pair the App to your RV to access devices. See the App section of this manual for instructions on pairing.

The App includes Vehicle Health Monitor™ (VHM). VHM performs routine scans of up to 23 different RV electronic devices on the OneControl systems. VHM will notify you if it senses a device operating outside normal conditions.

The App connects from your smart device to the RV via Bluetooth®. Bluetooth range varies due to obstructions like walls and frames. 40 feet (12 meters) is typical.

## C. ONECONTROL TOUCH PANEL

### 1. Device Library

The OCTP's Device Library interface provides quick access to devices. The display may be customized to show your favorite devices. Aftermarket OneControl accessories can be added to the Device Library provided they are paired with the RV.

### 2. First Usage

After turning your Model G ON for the first time and activating the OneControl system, the Device Library will appear.

The screen is divided into two columns. The left provides access to battery voltage, Device Families, HVAC zones and water and fuel tank information in three rows of "widgets." The right column provides access to groups of specific devices. You may also build a list of Favorite devices.

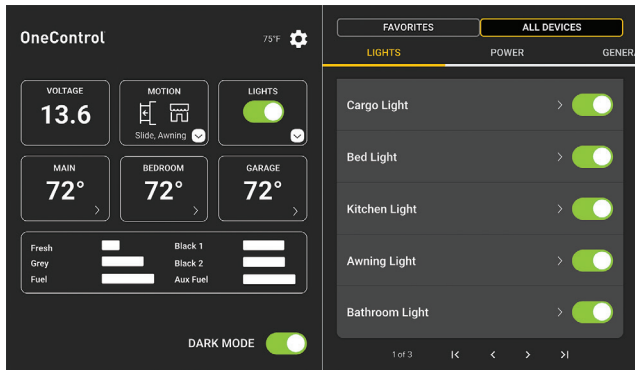

### 3. Device Types

There are two types of device controls. Devices like lights, pumps and heaters are Latching. Their status alternates between ON and OFF. For some devices like lights, the icon changes with status.

Some devices include additional controls. They are marked with an arrow in the lower right corner. To access controls, press and hold the button. They will be displayed in a separate window.

Devices like slides and awnings are Momentary. They activate only when their controls are being pressed. When the control is released, the device returns to the OFF position. This requires the control to be held by an operator during activation.

### 4. Battery Voltage

Because adequate Voltage is essential for the operation of many devices, it is displayed in the first widget. If you attempt to operate a device with an insufficiently charged battery, an alert will appear on the screen

### 5. Device Families

The second and third widgets provide access to Motion and Lighting “Device Families.”

### 6. All Motion

Pressing the ALL MOTION widget opens a page with access to slides and awnings. The page shows all slides available on the RV. Activate them by pressing their Extend and Retract buttons.

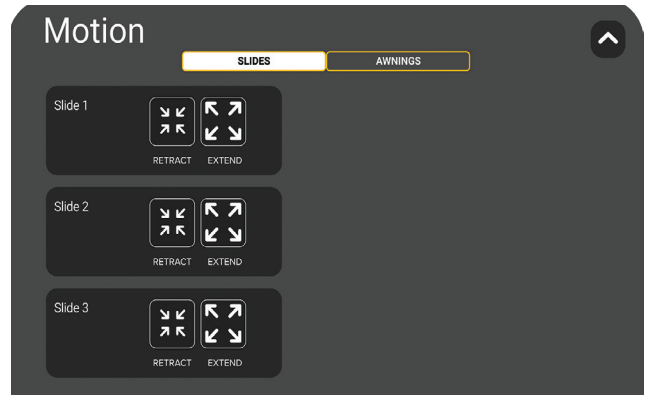

The selector at the top provides access to Awnings. Activate Awnings by pressing their Extend and Retract buttons.

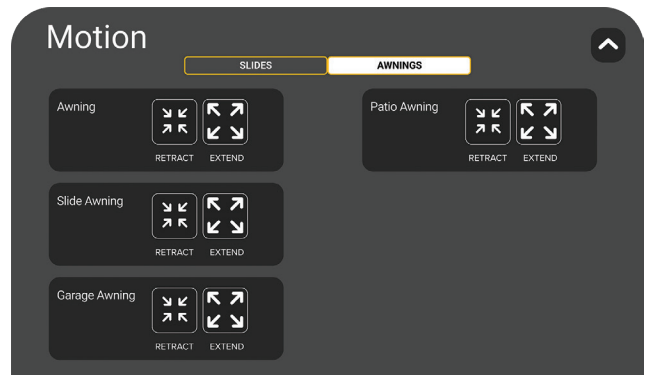

### 7. Wind Sensors

Three of your RV’s awnings are equipped with Wind Sensors (Awning and Slide Awning). Wind sensors provide protection during wind events by automatically retracting the awning.

Wind Sensors are delivered in the OFF position. To turn them ON, use the interface in the OneControl App. The interface allows you to operate the awnings, set a threshold and select a warning light. See the OneControl Mobile App section of this manual for more information.

After turning Wind Sensors on in the App, they appear in the OCTP. Access is provided with the arrow in the upper right of the Awning’s controls in the Motion page.

Access to Wind Sensor Settings in the OCTP depends on your RV's build date. In some RV's, you will be able to see status only, reflecting settings made in the app. In later models, you will be able to change settings from the OCTP.

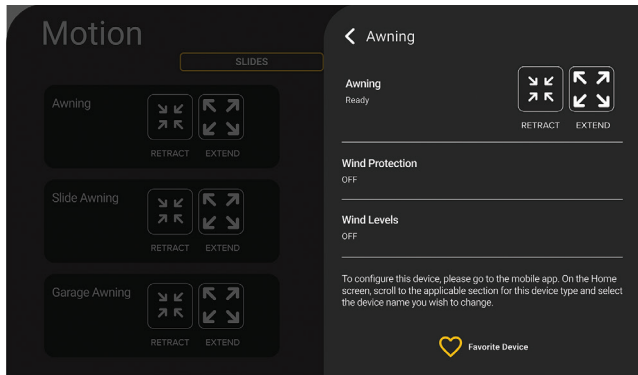

## 8. Wind Sensor Operation

Wind Sensors enable awnings to behave differently than other Momentary switches.

When equipped with a wind sensor, and provided the sensor's wind detection setting is ON, the sensor will automatically retract the awning if it senses gusts in excess of the detection setting. Retraction is accompanied by a warning chime and flashing light.

### + NOTICE

It is important to make sure there are no obstructions in the path of the awning or attached to the awning bar or mechanism, such as strings of lights, flags or other items.

In addition to automatic activation, wind sensors also enable automatic extension and retraction. This is achieved by double-tapping the switch.

### + NOTICE

Before activating automatic extension or retraction, make sure there are no obstructions in the path of the awning such as trees or items attached to the awning bar or mechanism, such as strings of lights.

Whether initiated by the user or from the detection of a wind gust, automatic extension and retraction may be canceled from the OCTP screen, any button on the Monitor Panel or from the App.

## 9. All Lighting

The "Lights" widget performs two functions.

Pressing it once turns all lights on the RV's OneControl system ON or OFF.

Pressing the arrow in the lower right corner opens a page featuring every light on the OneControl system. From this page, you can turn lights ON and OFF, and access premium controls like dimming.

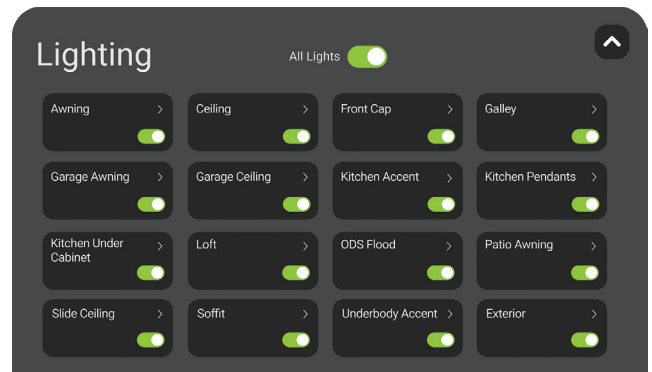

To turn lights ON or OFF, press the switch in the lower right corner. To access premium controls, press anywhere else on the button. Premium controls include dimming, color, sleep timer and behavior like pulsing and frequency. If your RV has more than 16 lights, you may swipe to the left to access them.

If a device has premium controls, they will open from the right:

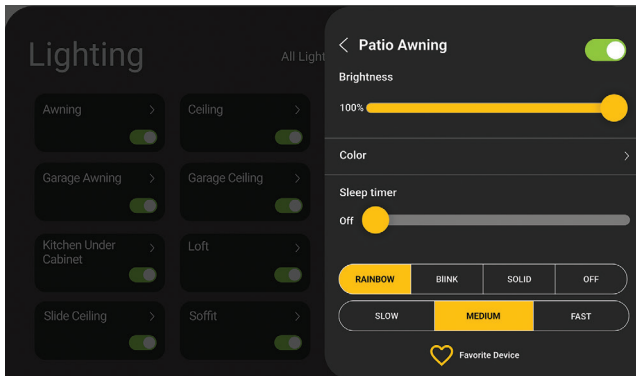

Press COLOR to change color values:

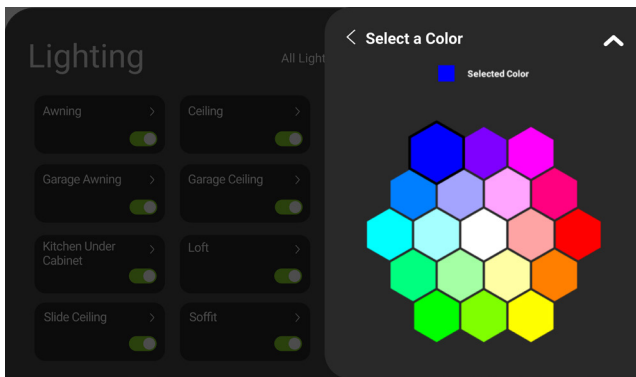

## 10. HVAC Zones

Pressing an HVAC zone widget opens a page showing the zone's options. You may adjust temperature, Mode, Fan speed and select a heat source.

Depending on your RV's build date, you may see one of two HVAC interfaces: Half- and Full-Screen.

The half-screen interface provides access to all HVAC zones and options in the right column:

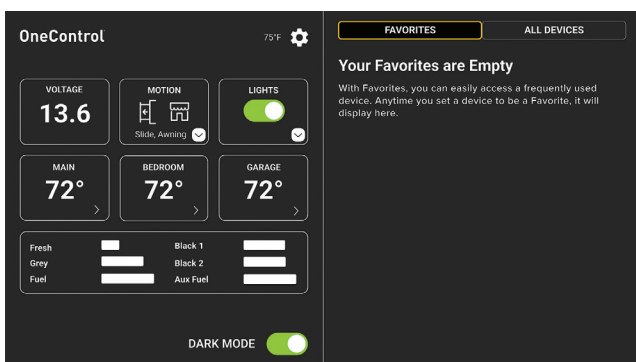

The full-screen interface launches a separate page with all zones and options.

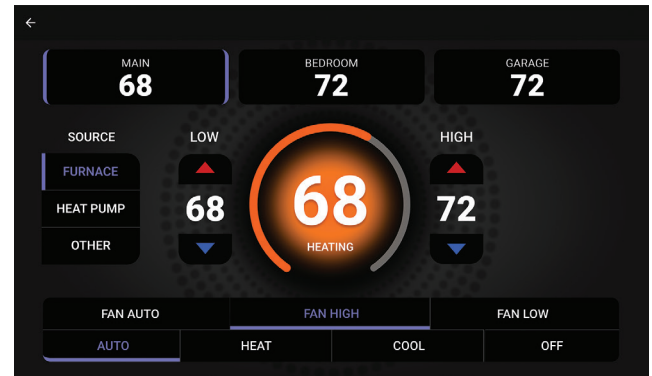

## 11. Modes

Your system includes 4 Modes:

- Heat.
- Cool.
- Auto.
- OFF.

If you select Heat, you will be offered a choice of sources:

- Furnace.
- Heat Pump.
- Other.

In Heat mode, you select a LOW temperature. If cabin temperature falls below this point, the system will activate your preferred heat source.

If you select COOL, you will be asked to select a HIGH temperature. If cabin temperature exceeds this point, the system will activate your air conditioner.

If you select AUTO, you will be asked to select HIGH and LOW temperatures. If cabin temperature exceeds either point, the system will activate your preferred heat source or air conditioner until the Zone's temperature falls within the desired range. The system automatically maintains a two-degree difference between high and low set points.

If you select OFF, the system will display temperature in each zone but will not activate any heating or cooling devices.



## 12. Fan

Your system provides 3 fan speeds:

- High.
- Low.
- Auto.

Even if you selected OFF in Modes, you may still circulate air with the fan by pressing Low or High.

## 13. Resources

Below HVAC zones is the tank status. The widget provides status of Fresh, Black and Grey water holding tanks, and the status of on-board fuel tanks (i.e. generator fuel).

Tank(s) status is reported in four increments:

- Full.
- 2/3.
- 1/3.
- Empty.

## 14. Favorites

The right side of the screen allows you to create a list of preferred devices.

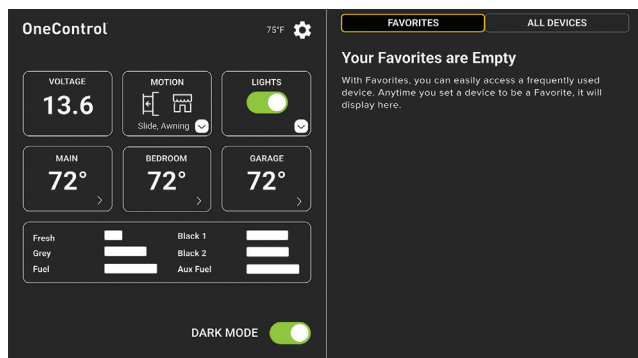

To favorite a device, go to its home page in the device library and select the heart icon at the bottom.

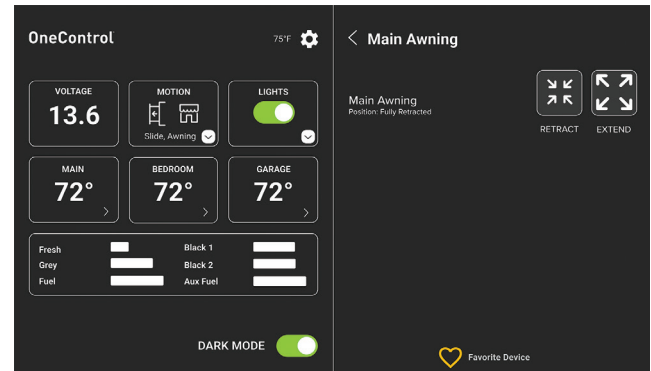

The device will be added to Favorites in the order in which it was selected.

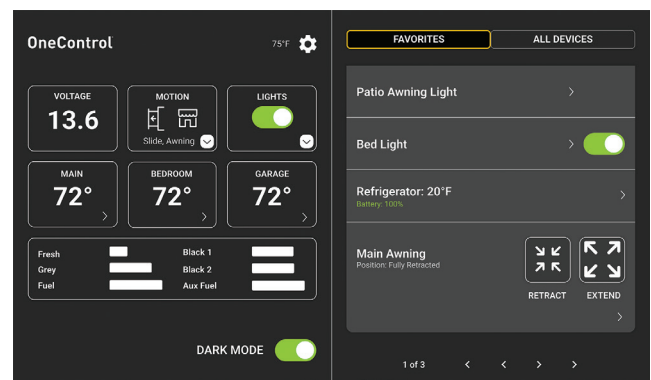

There is no limit to the number of favorites you may choose.

You may delete them by returning to the home page and deselecting their icon.

## D. DEVICE DETAILS

### 1. Generator

The OCTP provides access to customize your generator's behavior.

You may track uptime, set conditions under which the generator will automatically start and enable your generator to observe campground quiet hours.

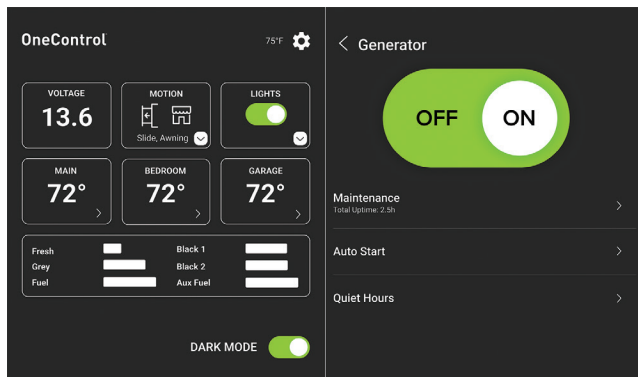

If you set the generator to start automatically, consider setting quiet hours. This will prevent the generator from turning on during a campground's observed quiet time.

To set quiet hours, you will need to input local time and day.

### 2. Leveling

To level your RV, you may operate Leveling controls from the OCTP. For more information about your leveling system, please See [Section 8](#).

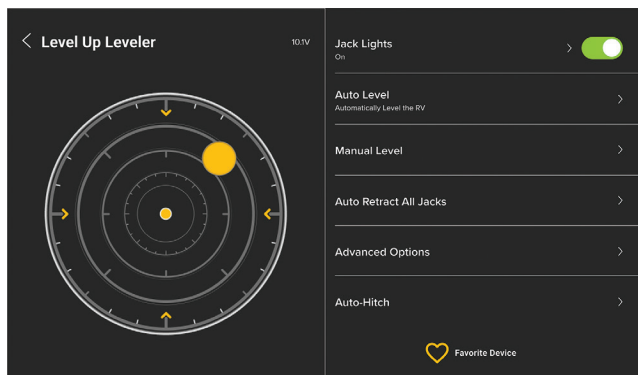

### 3. Accessories

If you add accessories, you'll pair them to the OneControl App first. Once in the App, follow the instructions to pair them to your RV. They will appear in the OCTP Device Library:

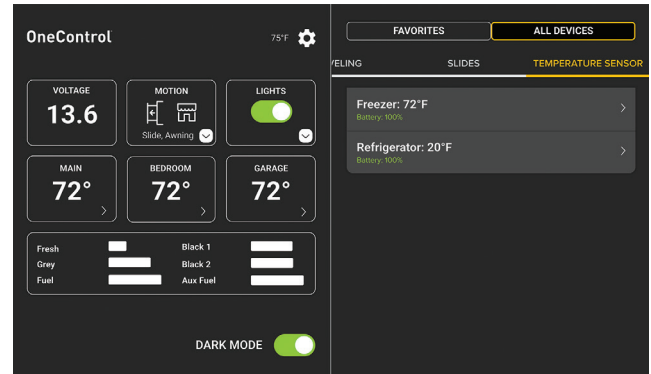

### 4. Camp Manager

Depending on your RV's build date, your OCTP may be equipped with Camp Manager™. Camp Manager provides an additional way to configure your OCTP's home screen.



# SEC.16 ONECONTROL

## E. MONITOR PANEL

For access to OneControl devices, you may also use the OneControl Monitor Panel. The Monitor Panel is mounted in the garage area of your RV.



### Resources

Along the top, you'll find holding tank levels and battery status. These match the tanks displayed on your OCTP and in the App.

Like OCTP, Fresh, Grey and Black tanks report four levels: Full, 2/3, 1/3 and Empty.

Fuel tanks are also displayed as four levels.

Battery status is displayed as Charged, Good, Fair and Poor. Levels correspond to specific voltage levels:

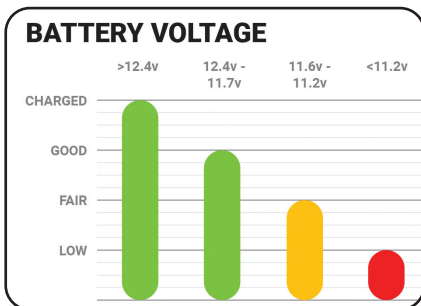

Located below holding tanks and battery status are buttons for RV devices. The top two rows provide access to latching devices like lights and water heater. These provide ON/OFF functionality only. When a device is turned 'ON', the button will change from white illumination to blue.

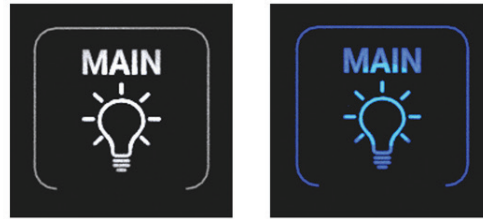

The lower two rows provide access to momentary devices like awnings and bed lifts.

At the center of the lower row is an infrared sensor. When the sensor detects something moving nearby, it will automatically illuminate the panel. After a few seconds, it will automatically turn off.

## F. ONECONTROL MOBILE APP

For greater convenience, all devices are available in the OneControl app.

The app is available in the Apple and Android app stores.



After downloading the app, you'll be asked to create an account. With an account, you can pair your app to your RV and operate RV devices.

### 1. App Pairing

To pair your RV, stand near the Monitor Panel with the RV powered ON.

In the app, locate the "+" icon. Press it to open the "Add and Manage" page.



Open the "RV Connection" page, select "Push to Pair" and follow the instructions in the app.



On the Monitor Panel, press the CONNECT button.

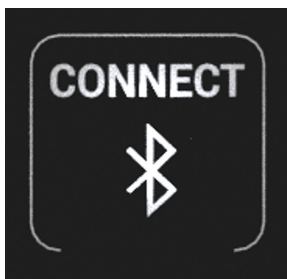

The RV's OneControl System and the app will sync, allowing access to RV devices on the OneControl system.

An unlimited number of users may pair to the RV.

At any time, as many as 3 people may use the app to operate RV devices.

### 2. App Access

The app and the RV communicate via Bluetooth.

Due to obstructions like walls, cabinets and frames, typical Bluetooth range is 40 feet (12 meters). Explore range by walking around the outside of your RV with the app open and connected to your RV.

### 3. App Functions

The app allows access to all devices available on the OneControl System.

### 4. Home Page

The Home page provides three options for accessing devices: ALL, MODES and FAVORITES.

The ALL page provides access to all devices and systems. Like the OCTP, the top includes widgets for battery voltage, lights, VHM, HVAC zones and water/fuel tanks.

Whenever an arrow is present in the lower right corner, the device includes additional functions. Tap the arrow to open the device's home page to see available functions.

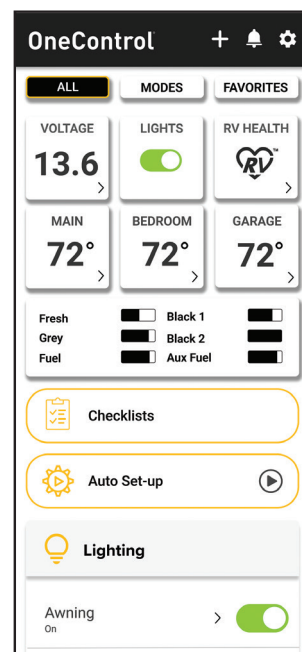

## 5. Modes

Modes allows you to customize device access based on where you are in your trip.

For example, the devices needed during set-up, like slides, are often different from the ones most needed while camping. Modes allows you to choose the devices you want at each part of your trip.

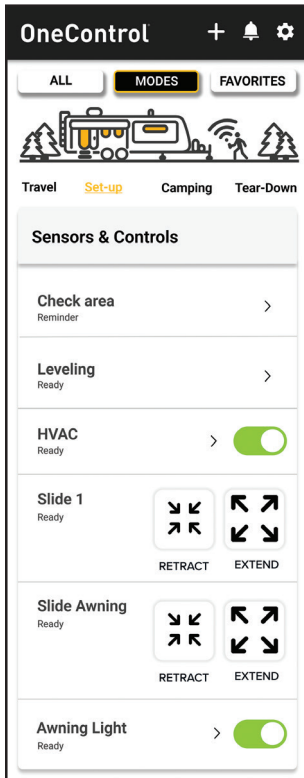

To personalize Modes, open the page and select one of the four options (Travel, Set-Up, Camping or Tear-Down).

Scroll down to see your RV's devices. Each Mode has been prepopulated with devices typically used during that activity. To change them, tap "Customize."

A short carousel will show you how to choose devices, change order and save:

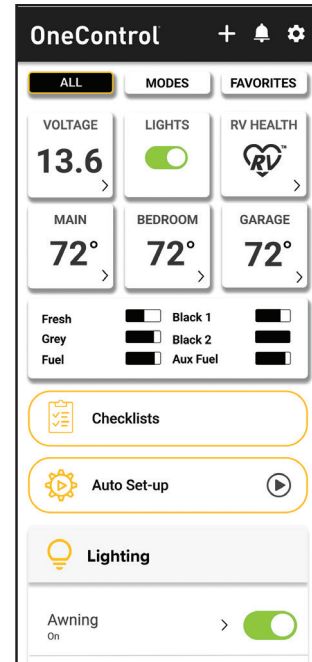

You can also add reminders to help with each activity.

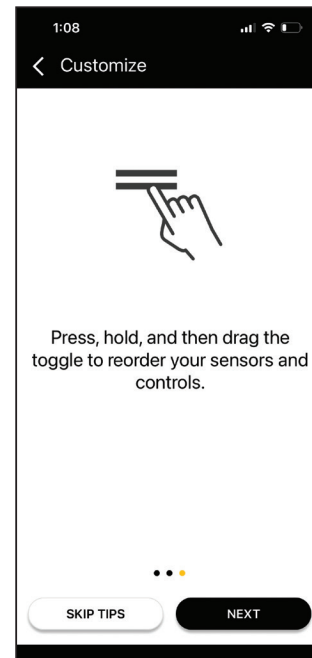



## 6. Favorites

FAVORITES is a blank canvas for you to customize. Press the Customize button to access all RV devices, then select devices and adjust order.

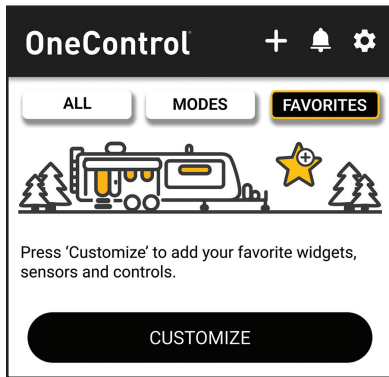

## 7. All Lights

This widget allows you to turn all lights ON or OFF simultaneously.

## 8. RV Health Monitor

RV Health Monitor™ is designed to quickly display the status of your RV's OneControl devices, provide tips on maintaining RV health and connect you with help when you need it.

RV Health Monitor communicates with the OneControl devices on your RV. When your phone is within range of your RV and has a cellular connection, open the OneControl mobile app. RV Health Monitor automatically scans information from OneControl devices and sends you a status update in the form of a webpage in a browser.

Depending on your RV's configuration, RV Health Monitor assesses the status of up to 23 RV systems like awnings, lights, slides and batteries.

Device status is reported with colors: red, yellow and green.

- If green, RV Health Monitor has assessed the device's electronic controls to be functioning within normal operating ranges. The device should be available for regular use.

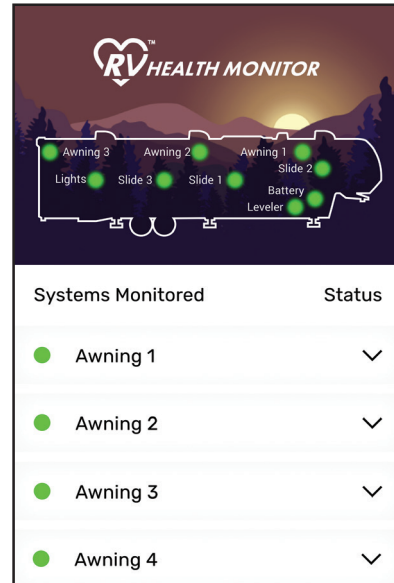

If yellow, RV Health Monitor has detected a variation in operating range that may benefit from close inspection or service. It may also mean a battery is severely depleted or is in poor health.

If red, RV Health Monitor has diagnosed a condition that requires immediate attention.

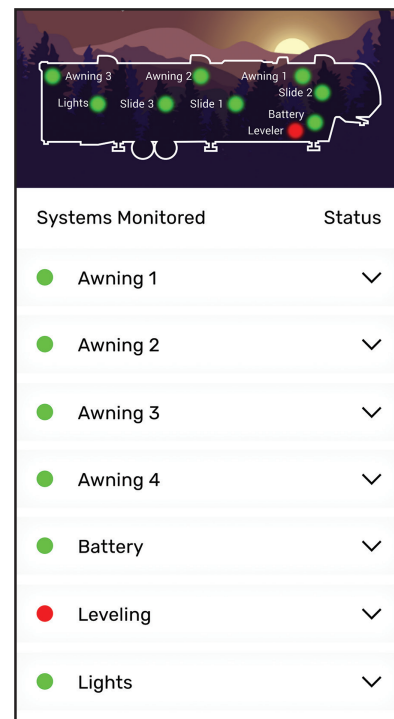

# SEC.16 ONECONTROL

In the event of yellow or red status, the RV Health Monitor includes recommendations for inspecting the device, then steps on how to resolve the issue.

Steps include tips, photos, videos and links to nearby dealers or service centers. You may also contact the Lippert Customer Care Center for assistance.

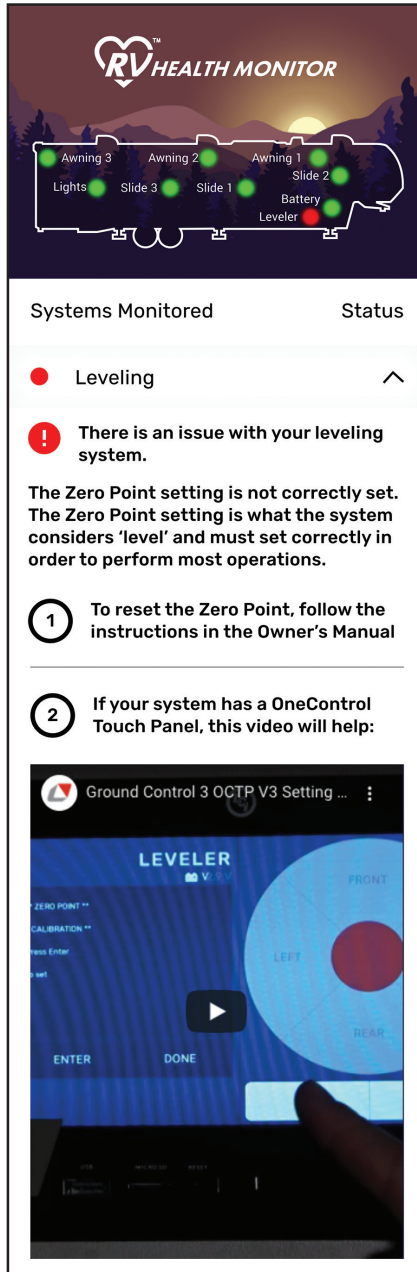

## + NOTICE

Even though RV Health Monitor can assess the performance of certain electronic controls inside a device, it's not able to see physical damage to the device or the RV.

Before taking a trip, inspect your RV and devices for excessive wear or damage. Always inspect devices according to manufacturer specifications or schedule an inspection with a qualified service center or technician.

## 9. Checklists

Below the tanks widget is the Checklist Builder.



This feature provides quick access to pre-populated RV checklists including Pre-Trip, Set-up and more. Scroll to the left to see each list.

The checklists are fully editable. You can make as many as you want.

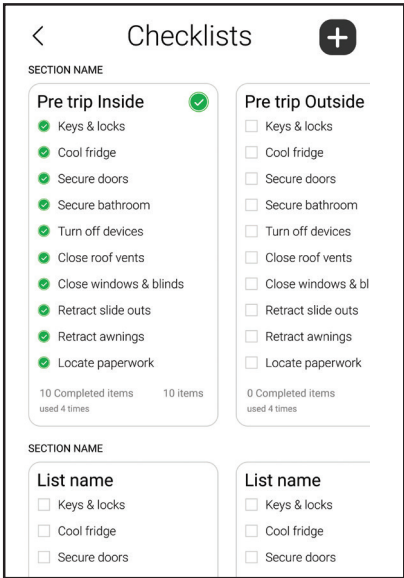

## 10. Auto Set-up

Your RV is equipped with Auto Set-up. Auto Set-up allows you to create an automated sequence of devices, like leveling, HVAC, lights and more.

- Auto Set-up is only available on the app.
- Only OneControl devices may be added to an Auto Set-up sequence.
- RV industry standards require slides to be activated manually.

To access the feature, press the Auto Set-up button below the widgets.



On first usage, you will be offered a brief video to help you create your sequence. It shows you how to select and change the order of devices, create reminders and save your sequence:

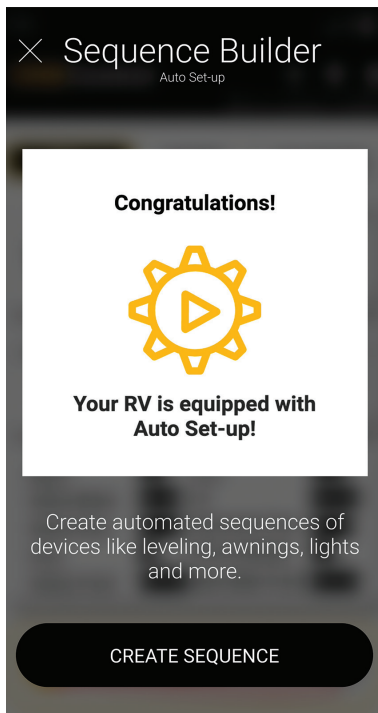

To design a sequence, open the Sequence Builder and give your sequence a name:

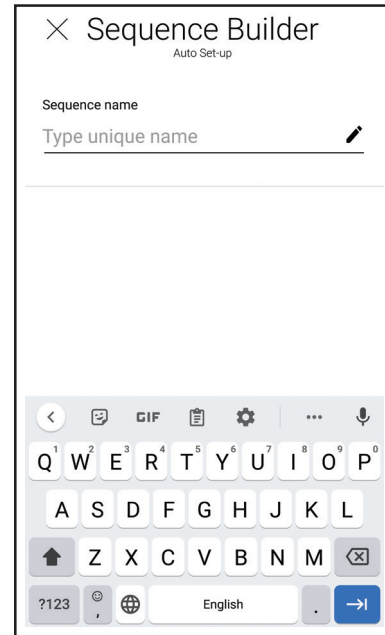

After saving your sequence name, choose the devices and order you want.

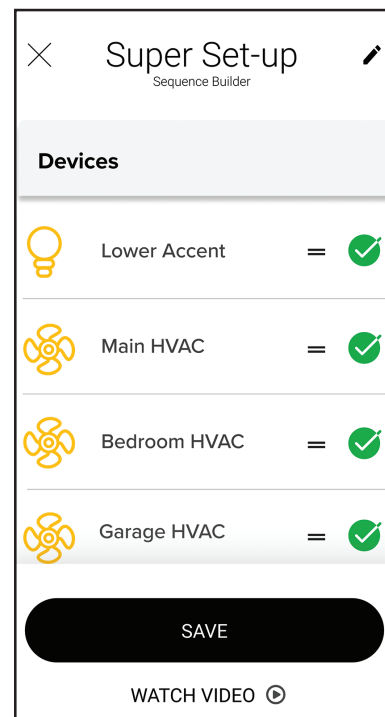

# SEC.16 ONECONTROL

When you're ready to run a sequence, return to the Home page. The name of your sequence will appear in the Auto Set-up button:



Pressing the button activates the sequence. All sequences start with tips for successful operation, including maintaining phone-to-RV communication and safety. As you grow more familiar with operation you may choose to skip these tips.

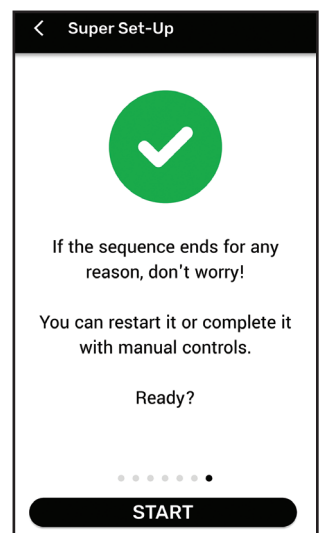
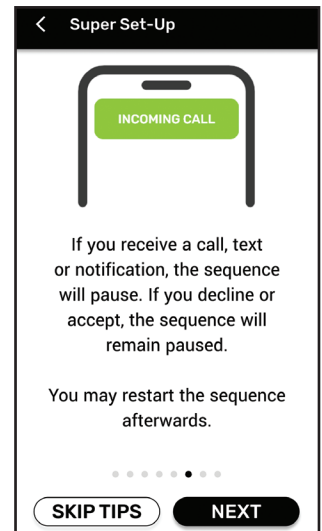
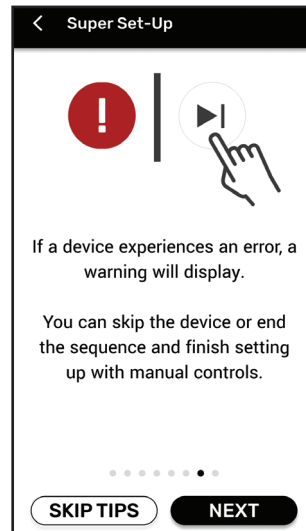
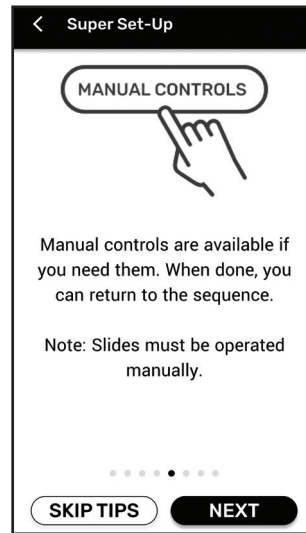
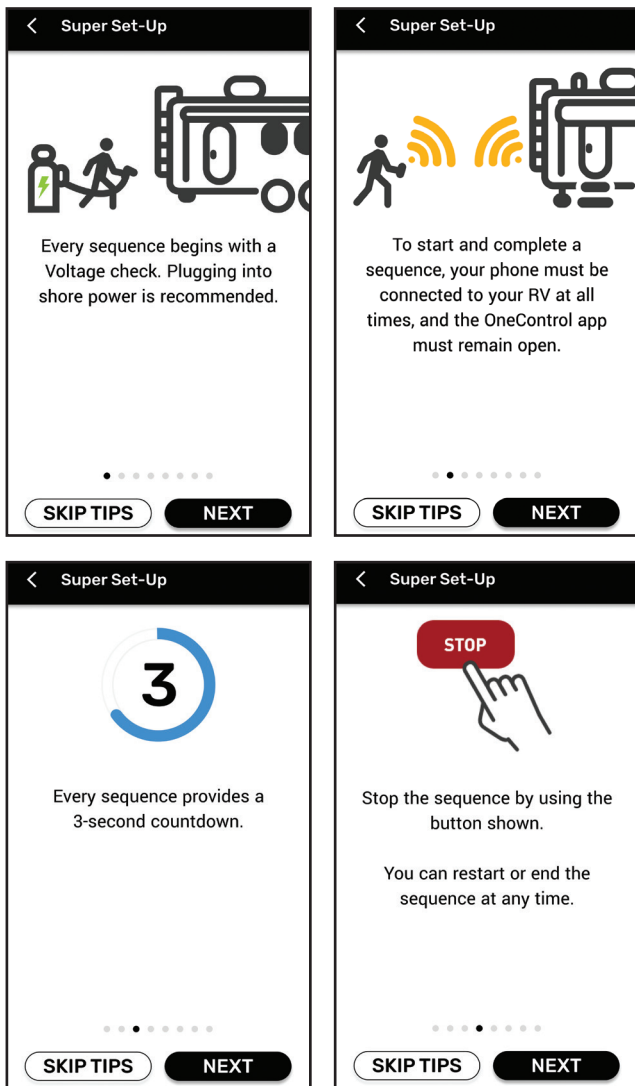

A sequence is like a music playlist – for your RV. The interface includes large STOP and PAUSE buttons. These show which device is active, the status of completion and the next device on the your list.

When a device is complete, you will see a confirmation. Most confirmations take less than a second.

You may also include custom reminders so you have time to perform manual tasks:

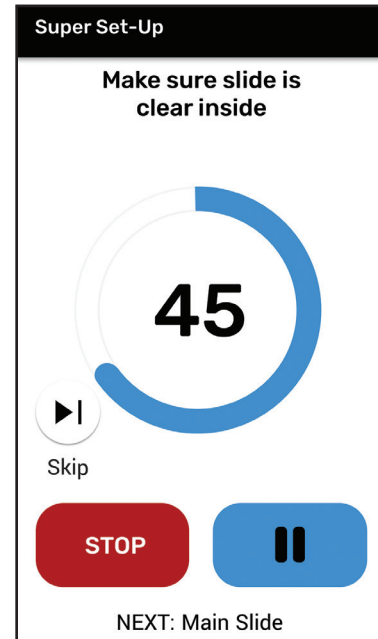
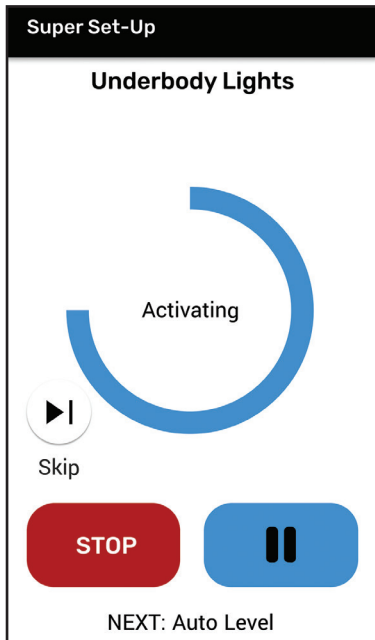

Some devices must be operated manually, like slides. To help access them quickly, you can add them to your sequence. The sequence will automatically present manual slide controls:

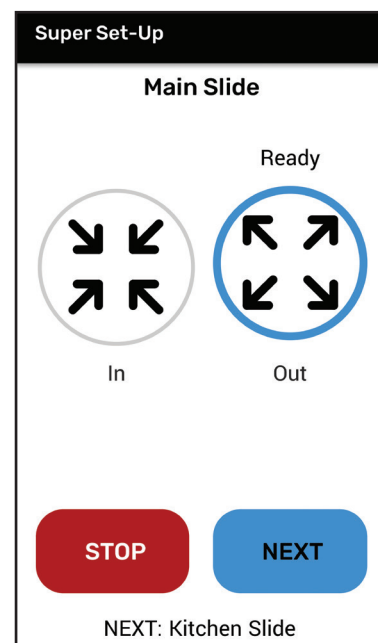



# SEC.16 ONECONTROL

Because more than one of your RV's awnings are equipped with OneControl Wind Sensors, you may add them to a sequence.

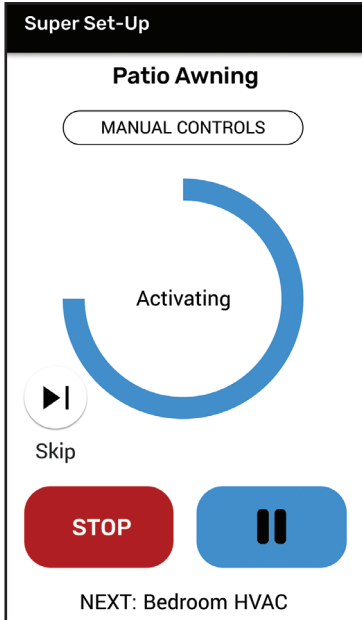

## + NOTICE

Before activating a sequence that automatically extends awnings, make sure there are no obstructions in the path of the awning such as trees or items attached to the awning bar or mechanism, such as strings of lights. At anytime you may use manual controls to operate the awning.

Should you receive a call or text during the sequence, the sequence shall pause and give you the option of answering the call. If you answer the call, you may restart the sequence afterwards.

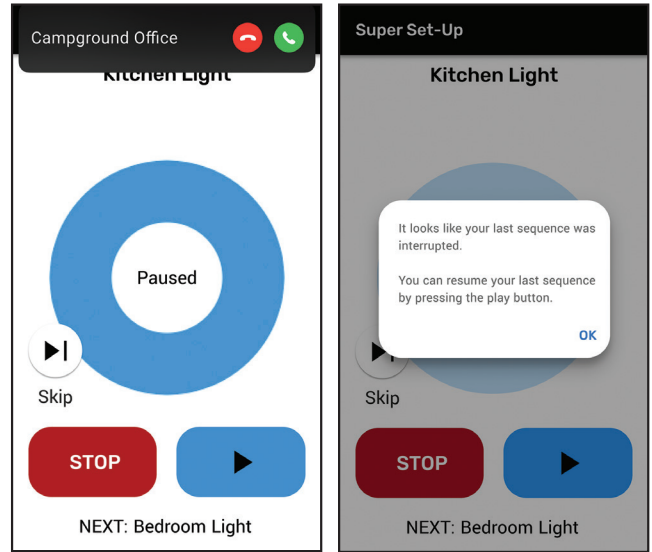

When your sequence is complete, you'll receive a notification. Following the notification, the Camping MODE will appear:



## 11. Device Library

Like the OCTP, the App's Device Library provides access to all OneControl devices. They are sorted into categories and displayed alphabetically, with the exception of Lights, which are listed first.

## + NOTICE

Only OneControl devices will be displayed in the OneControl app. Your RV may be equipped with devices not a part of the OneControl system. These will not show up in the app.

## 12. Wind Sensors

Two of your RV's awnings are equipped with Wind Sensors (Main Awning and Slide Awning). Wind sensors provide protection during wind events by automatically retracting the awning.

Wind Sensors are delivered in the OFF position. To turn them ON, use the interface in the OneControl App. The interface allows you to operate the awnings, set a threshold and select a warning light.

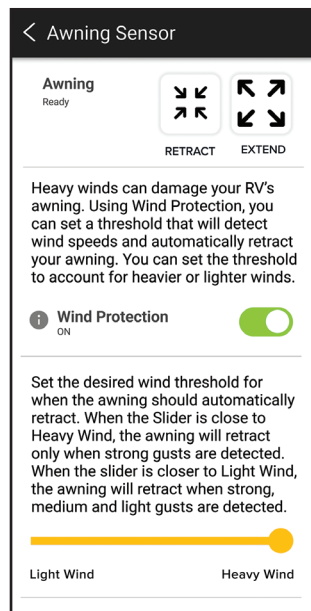
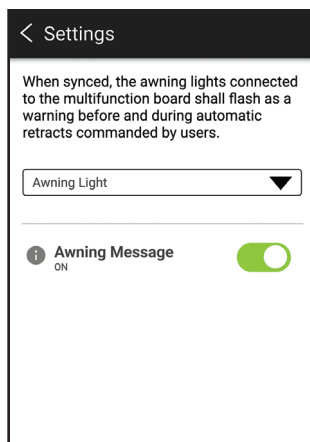

After turning Wind Sensors on in the App, they appear in the OCTP. Access them through the arrow in the upper right of the Awning's controls in the Motion page.

Access to Wind Sensor Settings depending on your RV's build date. In some RV's, you will be able to see status only, reflecting settings in the app. In later models, you will be able to access settings from the OCTP.

### Wind Sensor Operation

Wind Sensors enable awnings to behave differently than other Momentary switches.

When equipped with a wind sensor, and provided the sensor's wind detection setting is ON, the sensor will automatically retract the awning if it senses gusts in excess of the detection setting. Retraction is accompanied by a warning chime and flashing light.

It is important to make sure there are no obstructions in the path of the awning or attached to the awning bar or mechanism, such as strings of lights, flags or other items.

In addition to automatic activation, wind sensors also enable automatic extension and retraction. This is achieved by double-tapping the switch.

Before activating automatic extension or retraction, make sure there are no obstructions in the path of the awning such as trees or items attached to the awning bar or mechanism, such as strings of lights.

Whether initiated by the user or from the detection of a wind gust, automatic extension and retraction may be canceled by pressing anywhere on the OCTP screen, any button on the Monitor Panel or from the app.

## 13. Lights

Like the OCTP, certain lights include features like dimming and coloration. These controls are available.

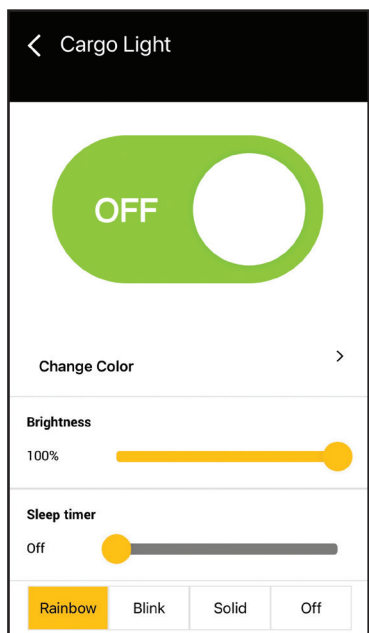

## 14. Generator

Like the OCTP, the Generator page allows you to customize generator operation. The page also includes an outside temperature display.

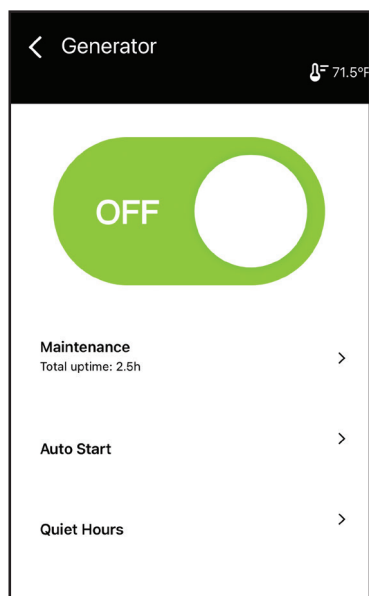

## 15. Leveling

The OneControl App supports the Level-Up® Leveling System on your RV.

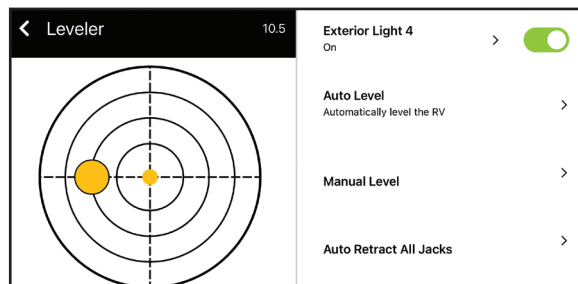

## 16. Bed Lifts

In addition to the Monitor Panel, you may use the App to operate Bed Lifts. Because this is a Momentary device, operation only occurs when you are pressing the buttons:

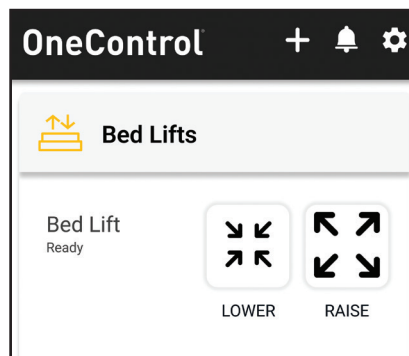

## G. CUSTOMIZATION

Upgrade your OneControl System with the latest smart devices and sensors.

### 1. Liquid Propane Sensors

Managing LP levels has never been easier. These sensors attach to the bottom of 20 lb (9.1kg), 30 lb (13.6kg), and 40lb (18.2kg) steel tanks with magnets, then communicate via Bluetooth to your phone and RV from the OneControl App. Find them here:



### 2. Temperature Sensors

Monitor food safety with fridge and freezer temperature sensors. They mount flush to the wall of your fridge, communicating via Bluetooth to your phone and RV from the OneControl App. Find them here:

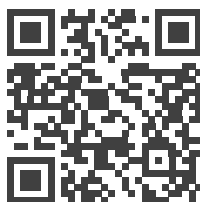

### 3. Keyless Bluetooth Door Locks

Lock and unlock your RV entry doors from your smartphone. This keyless RV door lock is an easy way to check lock status without leaving your bed or chair. Find them here:



## H. RESOURCES

The OneControl System and its components are supported by the Lippert Customer Care Center.

### Hours of Operation

Monday - Friday: 8AM - 7PM (ET)  
432-LIPPERT (432-547-7378)

### For Emergencies:

Press 1, to be connected to our after-hours emergency team.

*Products and graphic user interfaces depicted in this manual are subject to change.*

*Lippert™, Level-Up®, OneControl®, Auto Set-Up™, and Vehicle Health Monitor™ are trademarks of Lippert Components, Inc.*

*The OneControl app is available for free on Apple App Store® for iPhone® and iPad® and also on Google Play™ for Android™ users.*

*iPhone®, App Store® and iPad® are registered trademarks of Apple Inc.*

*Google Play™ and Android™ are trademarks of Google Inc.*

# SEC.17 HEATING & COOLING (HVAC)

## A. INTRODUCTION

Within this section you will find information on the original heating and cooling (HVAC) components installed in your RV by Brinkley RV. Please know that if any of these components were replaced after the RV left the factory as an aftermarket installation, this information does not apply to those aftermarket items. For additional information, please refer to the manufacturer's manuals found in Owner Information Package or visit their direct website. In the circumstance an aftermarket modification or installation has been performed on your RV, please contact the servicing Dealer who performed the work for additional information.

### + NOTICE

Sufficient power is vital for proper operation and efficiency of the A/C. Insufficient power may lead to damage to your A/C.

## B. AIR CONDITIONER WITH HEAT PUMP

The A/Cs within your RV are GE, ducted, 13.5 BTU air conditioners that contain heat pumps. Each A/C can be individually operated and controlled by the thermostat through your OneControl system. Please See [Section 16](#) for OneControl operation instructions.

### 1. Ducted A/C

A ducted RV A/C is similar in setup to an A/C in a residential home. It contains duct work that assists in the deliverance of chilled air to a designated location within the RV. In Model G, there are three A/C's installed in the RV; the front bedroom, the kitchen/living room area, and the garage.



### 2. Duct Work and Return Air

The adjustable registers and vents installed in the RV are designed and intended to **REDUCE** and adjust airflow, **NOT** to fully inhibit airflow. Registers must remain free and clear of any obstruction that may inhibit airflow from passing through the air return. Care should also be taken to ensure that debris and other small items do not pass into the air returns.

### ⚠ CAUTION

**Do not operate the air conditioner without the return air filter. Operation without this filter will allow debris to pass-through and accumulate on the cooling coils. Over time, this will lead to loss of efficiency in cooling, air volume loss, equipment damage, and professional cleaning expenses.**

### + NOTICE

Registers should NEVER be fully closed and NEVER fully obstruct the airflow.

### 3. Heat Pump

Each A/C within your RV contains a heat pump. This feature provides an additional heat source for the RV and is specifically designed to help remove the chill from the RV. Heat pumps can be operated independently or in conjunction with the furnace. In addition to being a heat source, the heat pump also ensure that any ice buildup on the heat exchanger is cleared by periodically cycling to Auto Defrost. For operation, utilize the thermostat found in OneControl system.

### + NOTICE

For best operation, it is advised not to use the heat pump system when temperatures drop below 28° F (-2.2° C).



#### 4. Cooling vs Heat Gain

The A/C on the RV is designed to cool intake air (outside air) by approximately 15° to 20° F (-9.4° to -6.7° C). Please know that environmental surroundings, the location of your RV, and other conditions may affect the efficiency in performance of the A/C. When located in hot climates with little to no protection to the RV (no trees or surrounding shade), the RV will absorb the heat from the sun and increase the temperature inside the RV. This process is referred to as “heat gain.”

Reducing the RV heat gain is important to obtain a comfortable temperature inside the RV. Following the below instructions will help to reduce heat gain within your RV.

##### REDUCING RV HEAT GAIN:

1. Park the RV in a shaded area with plenty of airflow.
2. Close all the blinds.
3. Keep all doors and windows closed.
4. Extend the awnings to provide additional shade.
5. Avoid the use of heat producing appliances such as the oven or stove top.
6. Set the A/C mode to high. When encountering high humidity or high temperatures, this will help provide maximum cooling efficiency.
7. Turn ON the A/C as early in the day as possible. This will allow the A/C to cool the RV prior the outdoor temperature rising throughout the day.

#### 5. Air Conditioner Gasket

Between the roof material and subframe of the A/C, there is a foam gasket that acts as a weather-proof seal. Because the A/C is subjected to wind pressures and motor vibrations, this seal should be inspected every six months. To inspect the gasket,

you must remove the air distribution box located in the interior ceiling in the location of the A/C unit. The photo below shows what the A/C distribution cover looks like for reference. Check for leaks and re-tighten any loose mounting bolts as needed. Be careful to not to over-tighten the mounting bolts. Doing so may result in the seal becoming damaged.



Over time, the A/C gasket will need to be replaced. To gain access to the mounting bolts, the A/C shroud and filter from inside the RV will need to be removed. From there you will be able to carefully remove the bolts and gain access to the seal itself.

Please see the manufacturer’s manual for more information and instructions.

#### C. FURNACE

The OneControl in the RV controls the function of the furnace. The OneControl tablet is located near the main entry door of the RV. A photo of the OneControl tablet is provided below. For full operation, the furnace requires both 12-volt power and propane gas. Sufficient power is required to properly function the furnace.



## SEC.17 HEATING & COOLING (HVAC)

The furnace itself is in the sidewall of the RV on the off door side of the RV and is beside the water heater. The photo below shows the location of the furnace. For additional information pertaining to the operation, maintenance, and troubleshooting of the furnace, please consult the manufacturer's manual.

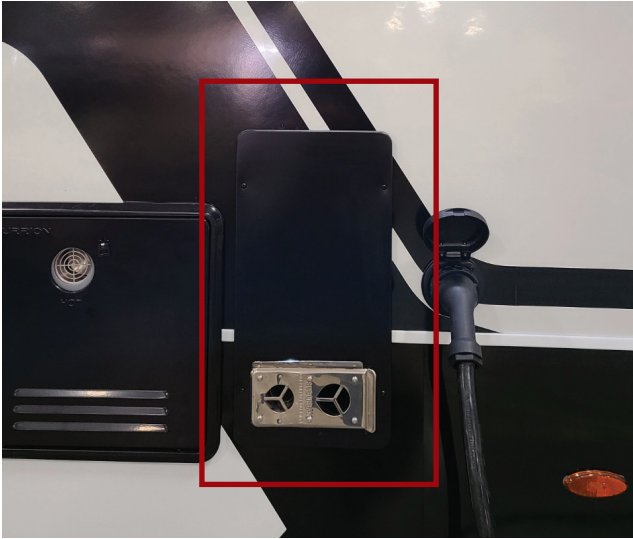

### + NOTICE

Never attempt to repair a furnace if it is not functioning properly. Furnace maintenance should always be completed by a qualified technician. Only OEM parts are to be used when parts are needed. Inspection and maintenance should be performed on an annual basis, or more frequently if heavily used. Please contact your Dealer with further questions, concerns, or to obtain service.

### ⚠ WARNING

**DO NOT** obstruct airflow going to or from the furnace for any reason and do not modify the installation. Doing so will cause unsafe furnace operation and ultimately can lead to damage to the furnace, personal injury, or fire.

### ⚠ WARNING

**DO NOT** operate the furnace while slide-out rooms are fully retracted in the closed position. This will prevent proper airflow from occurring and may cause the backup of exhaust and heat resulting in additional wear on the furnace.

## D. FIREPLACE

Your RV may have a fireplace (If Equipped) in the main living area. A picture of the fireplace is provided below. The control panel is located in the upper right hand of the fireplace as indicated by the red circle on the photo. These control buttons permit you to change the lighting, heat intensity, and to set a timer so that the fireplace shuts off automatically. The provided remote also provides control of all features.



### The Power Button

The power button turns the fireplace on and off. Once on, if the fireplace display is not illuminated, pressing the power button will light up the display. The power button has a built-in memory function that will retain the status of the fireplace when turned off. With the exception of the timer, the fireplace will restart in its previous status. If the fireplace is disconnected from the main power source, it will lose the memory and restart at the default settings.

### The Flame Button

Each time the flame button is pressed, the colors of the flame will change. There are four color settings: orange, blue, combination, and cycling (which included white, blue, and orange). The timer setting ranges from 30 minutes to 9 hours.

### The Coal Bed Button

Each time the coal bed button is pressed, the color of the rock bed will change. There are four color settings: orange, blue, white, and combination. The timer setting ranges from 30 minutes to 9 hours.

### The Heat Button

The heat button turns the heater on and off. When the heater is on, press the heat button until the desired setting is obtained. There are HI and LOW temperature settings that range between 62° - 84° F (17.8° - 28.9° C).

### The Timer Button

The TIMER has adjustable setting with range from 30 minutes to 9 hours and OFF. Once you have set the timer, and the timer is up, it will shut off all functions and enter standby mode. In this mode, you must touch the power icon to restart the fireplace.

## E. ROOF VENTS

There are three roof vents installed on the RV: one in the rear bath, one in the main living area, and the other in the front bath. These vents are electric and are intended to allow for additional airflow in the RV. Each vent can be operated via a wall mounted remote. This remote is shown below along with a photo of the vent. The location of each remote varies depending on floor plan, but will remain in close proximity of the vent itself.



### + NOTICE

Never leave a vent open while the RV is being stored or for long periods of time. High winds, rain, animals, or other obstructions may cause damage or a leak leading to damage to the RV that may not be warrantable.

# SEC.18 AWNINGS

## A. MAIN AWNING-SOLERA

The Solera® Power Awning installed on the RV is operated by an electric motor and can be controlled by the awning switch found on the command center, the OneControl app, or One Control Touch Panel found within the RV. These controls are shown below.



COMMAND CENTER



ONECONTROL TOUCH PANEL



ONECONTROL APP

The installed awning contains adjustable, friction joint arms rather than traditional locking pivot arms. This allows for easy adjustment and manipulation of pitch when needed. It also helps to prevent damage to the arms during wind events.

### 1. Awning Extension

a. Prior to operating the awning, make sure the battery is fully charged and the RV is connected to external shore power.

Ensure there are no obstructions preventing the awning from freely retracting.

b. Press and hold the **EXTEND** button found on the command center, the OneControl app, or OneControl tablet to fully extend the awning.

c. For partial extension, press and hold the **EXTEND** button until the awning reaches the desired position. The awning is fully extended when the valance on the awning is pointed downward towards the ground.

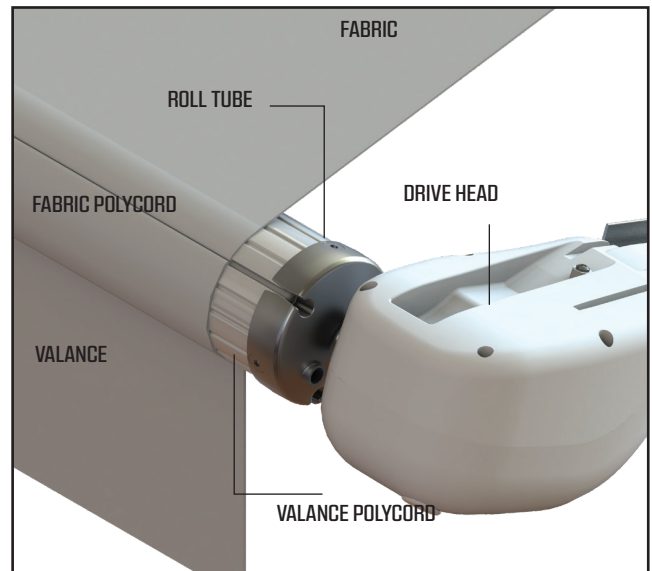



### + NOTICE

Maximum extension is met when the fabric is completely unrolled and taut. When fully extended, the valance seam and a section of the roll tube will be visible and pointing down towards the ground. As soon as this is seen, be sure to stop extension right away.

The awning canvas should always be on top of the roll tube rather than under. If the awning is over-extended the awning will begin to retract in reverse and will flip the canvas to the under portion of the roll tube. If this occurs, press the **RETRACT** button until the awning fully extends and then corrects to retraction.

### ⚠ WARNING

Keep clear of any and all moving parts while the awning is in operation. As the awning functions and closes against the unit, there is a risk of being pinched, cut, and crushed.

## 2. Retracting the Awning

- a. Prior to operating the awning, make sure the battery is fully charged and the RV is connected to a power source.  
  
Ensure there are no obstructions preventing the awning from freely retracting.
- b. Press and hold the **RETRACT** button found on the command center, the OneControl app, or OneControl tablet to fully retract the awning.
- c. For partial retraction, press and hold the **RETRACT** button until the awning reaches the desired position.

### ⚠ CAUTION

This manual is intended to provide operational instructions for the Solera® Power Awning installed on the RV. Operating the awning in any other manner other than what is described within this manual, or the manual provided by the manufacturer may result in damage to the awning or RV, the warranty, property damage, and/or personal injury.

### + NOTICE

The pitch of the awning does not need to be corrected to retract the awning.

### ⚠ CAUTION

While there is heavy wind, heavy rain, or during extended time away from the RV, the awning should be fully retracted. This will help to prevent damage to the awning and RV.

### ⚠ CAUTION

Do not tie down the roll tubes on the awning. This prevents the free floating, tension arms from functioning as designed. Doing so may result in damage to the awning or to the RV.

## 3. Pitch Adjustment—Solera Awnings

If water begins to collect on the awning, the pitch of the awning will automatically adjust to purge the excess water. The auto-dump feature of the awning prevents damage from occurring to the awning and may occur without notice.



## SEC.18 AWNINGS

Adjusting the pitch of an awning will allow water to runoff as it begins to collect on the canvas and can be done by adjusting one awning leg lower than the other.

### SETTING THE PITCH:

1. Begin by extending the awning to the desired position.
2. Select the side that is most convenient for water runoff.
3. Adjust the leg by pulling downward on the joint until the desired pitch is obtained to allow for proper water runoff to occur.
  - a. Major adjustments do not need to be made and should be performed on an as needed basis.
  - b. Never push the joints in an upward motion. Doing so may cause additional stress on the strut causing damage or failure.
  - c. The bolt and washer on the friction joint (**Fig. A**) allow the arm to remain in the set position.

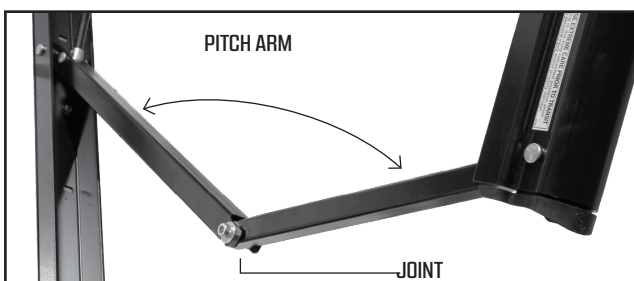

### + NOTICE

The pitch of the awning does not need to be corrected to retract the awning.

### + NOTICE

If the manipulated arm does not hold in position, tighten the bolt at the joint displayed in Figure A on the prior page.

### 4. Maintenance—Solera Awnings

Proper maintenance and usage can help to extend the life of the awning. If you must retract the awning while the canvas is wet, fully extend the awning, when conditions allow, so proper drying can occur. This should be done right away to help prevent mold and mildew from forming.

### CLEANING THE AWNING CANVAS:

1. Mix ¼ cup of dish soap with five gallons of warm water.
2. Apply the mixture to the canvas and fully retract the awning for five minutes. This will allow the mixture to encounter both sides of the canvas material.
3. After the allotted time, fully extend the awning and rinse the canvas with fresh water.
4. Repeat as many times as needed.

### + NOTICE

If mildew forms, it is not on the fabric itself, but on the accumulated dust and debris. If mildew is present, clean the canvas material immediately.

## 5. Troubleshooting—Manual Override

In the event that power is lost or the motor fails, the awning can be extended and retracted utilizing the manual override.

### FOR MANUAL OVERRIDE:

1. Open the hinged cover plate on the drive motor head (right awning head when facing the unit). The cover can be opened by pulling in an up and outward motion from the bottom of the awning head cover.
2. To expose the manual override nut, remove the rubber grommet from the drive head assembly. This is located on the top right section of the awning when looking at the RV.
3. Use a 7/16" socket on the head assembly to extend and retract the awning.
  - a. Clockwise will extend the awning.
  - b. Counterclockwise will retract the awning.
4. When the awning is completely retracted, remove socket or drive device and replace the rubber grommet in the drive head assembly. Replace the cover.

### CAUTION

A step stool or ladder may be required when manually operating the awning. Use these tools with caution. Improper use may lead to damage to the RV or personal injury.

### + NOTICE

It is recommended for a power tool to be utilized while manually extending or retracting the awning. The use of a manual ratchet will take a significant amount of time to fully extend or retract the awning.

### + NOTICE

Manual override, or manual operation may be used to extend or retract the awning while dry camping without a battery or power.

For additional information on awnings, you can also refer to the owner's manual at [lci-support-doc.s3.amazonaws.com/manuals/master-owners-manual/ccd-0001573-01.pdf](https://lci-support-doc.s3.amazonaws.com/manuals/master-owners-manual/ccd-0001573-01.pdf).

## B. SLIDE TOPPER AWNINGS—DOMETIC

### CAUTION

**PINCH HAZARD.** Do not operate the RV slide-out room or Slide Topper if people or objects are in the travel path of the RV slide-out room. Failure to obey this caution could result in minor or moderate injury.

### + NOTICE

Do not close the RV slide-out room or the Slide Topper with leaves, sticks, or other debris on the awning fabric. Damage to the fabric or Slide Topper can occur.

### + NOTICE

If the RV slide-out room is left open during rainy conditions, water may collect on the Slide Topper. This will cause water to spill over the sides as the RV slide-out room closes and the Slide Topper closes.

# SEC.18 AWNINGS

## 1. Operation

The Slide Topper automatically opens and closes as the RV slide-out room opens and closes. See [Section 09](#) for information on how to operate the slideouts on your Brinkley RV.

## 2. Maintenance

### **⚠ WARNING**

**Fire, Impact or Crush Hazard: Frequently examine the product for imbalance (uneven fit/sagging/loose parts), signs of wear or damage to wiring (if applicable), and other critical parts. Critical parts include awning fabric, brackets, and arm assemblies, etc. Do not use product if adjustments or repairs are necessary. Failure to obey the following warnings could result in death or serious injury.**

### **+ NOTICE**

Please refer to the following precautions to ensure product damage or deterioration does not occur:

- Do not use insecticides or other sprays near the awning fabric. These could cause stains and adversely affect the fabric's ability to repel water.
- Do not expose the Slide Topper to adverse environmental conditions, corrosive agents, or other harmful conditions.
- Never close the Slide Topper for storage when it is wet. The combination of moisture and dirt could result in mildew, discoloration, and stains.
- If it is necessary to temporarily roll up the slide Topper while it is wet, make sure you roll it out and let it dry (as soon as conditions allow) before rolling it up again.
- Never close the Slide Topper if you have applied a vinyl liquid patch (VLP) and it is

wet. Damage to other parts of the awning fabric will occur.

- Do not use strong chemicals or abrasives to clean parts as their protective surfaces will be damaged.
- Do not use silicone sprays near labels. The labels adhesive bond to the product surfaces could weaken.
- Do not use abrasive or corrosive cleaners, mildew removers, or hard bristle brushes on the awning fabric.
- Do not allow dirt, leaves, or other debris to accumulate on the Slide Topper. This could cause abrasions and stains. Mildew could grow on the dirt and organic debris causing permanent discoloration, stains, and odors on the awning fabric.

The Slide Topper fabric and hardware require regular maintenance. Refer to these sections for maintenance instructions.

### **a. Maintaining the Hardware**

Perform the following maintenance checks on the Slide Topper hardware regularly:

- Clean the Slide Topper hardware as needed with a mild surface cleaner.
- Apply silicone spray lubricant as needed to keep the FRTA's moving parts operating smoothly.

### **b. Maintaining the Fabric**

Vinyl fabric offers the advantage of durability and water resistance.

Wrinkling is a normal characteristic of vinyl. Wrinkling may be more noticeable when retracted, and after prolonged periods of stowage.

Leave the Slide Topper open during warm weather to minimize the wrinkling over a period of time.

### c. Cleaning the Fabric

Perform the following actions to clean the awning fabric.

#### CLEANING THE AWNING FABRIC:

1. Mix one quarter of a cup of dish soap and one quarter of a cup of bleach with five gallons of fresh water to use as cleaning solution.
2. Drench the open awning fabric with the cleaning solution.
3. Close the awning and let it soak for five minutes.
4. Open the awning.
5. Thoroughly rinse off the top and bottom of the awning fabric with clean water. Completely remove the cleaning solution from the awning fabric. Bleach will degrade the awning fabric if it is not completely removed from the awning fabric.
6. Repeat step five as necessary to completely remove the cleaning solution from the awning fabric.
7. Allow the Slide Topper to thoroughly dry before stowing.

### d. Repairing the Fabric

To repair a pinhole or a spot where the coating has flaked off the top layer of the vinyl fabric, perform the following actions:

1. Apply a small dab of VLP (vinyl liquid patch) onto the tip of a cotton swab. VLP is available from Dometic. Reference part number 3314216.000 for ordering.
2. Gently roll the cotton swab around the pinhole. The VLP will melt the coating and quickly fill the pinhole blending with all colored vinyls.
3. Allow the VLP to thoroughly dry before stowing.

## C. REAR PATIO AWNING—THULE

Your Model G is also equipped with a Thule rear patio awning located above the ramp door.

The Thule rear patio awning is operated by a 12V electric motor and can be controlled by the awning switch found on the command center located in the garage. A picture of the command center is shown below:



# SEC.18 AWNINGS

## 1. General Safety

### ⚠️ WARNING

Do NOT modify this product in any way. Modification can be extremely hazardous.

### ⚠️ WARNING

**IMPACT OR CRUSH HAZARD. NEVER** leave an open awning unattended. Keep awning stowed (closed) when snow, heavy rain, wind, and severe weather conditions are expected. Failure to obey this warning could result in death or serious injury.

### ⚠️ WARNING

**IMPACT OR CRUSH HAZARD. Do NOT** allow water to pool, snow to accumulate, or heavy debris on awning fabric. Do NOT hang or place anything on awning. The awning will become unstable, and could bend or collapse. Failure to obey this warning could result in death or serious injury.

### ⚠️ CAUTION

**PINCH HAZARD.** Maintain a horizontal distance of at least 16" between fully open awning and any permanent object. Failure to obey this caution could result in injury.

## 2. Operating the Awning

- a. Press and hold the extend button for the awning from the command center located in the garage of the RV. Note that the awning will automatically stop when the extend button is released. This permits you to either fully extend the awning or leave it partially extended.
- b. To close the awning, press and hold the retract button for the awning from the command center located in the garage of the RV. Prior to transit, the awning must be fully retracted.

## 3. Manually Overriding the Awning

In the event that you lose power to the RV or the awning motor on the rear patio awning does not function, you can manually override the awning.

When facing the rear of the unit, the manual override is located on the left side of the awning. There is a rubber plug that must be removed to access the override. A picture of the override locations is shown below:

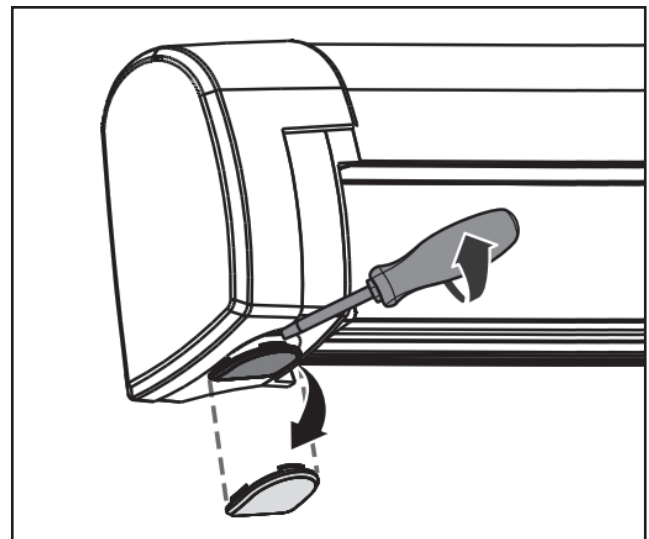



1. Remove the rubber override plug utilizing a flat head screwdriver.
2. Locate the provide manual override crank handle.
3. Insert the crank handle into the manual override on the awning.
4. Rotate the crank handle counter-clockwise to retract the awning and clockwise to extend the awning.
5. Remove the crank handle and replace the rubber override plug when completed.

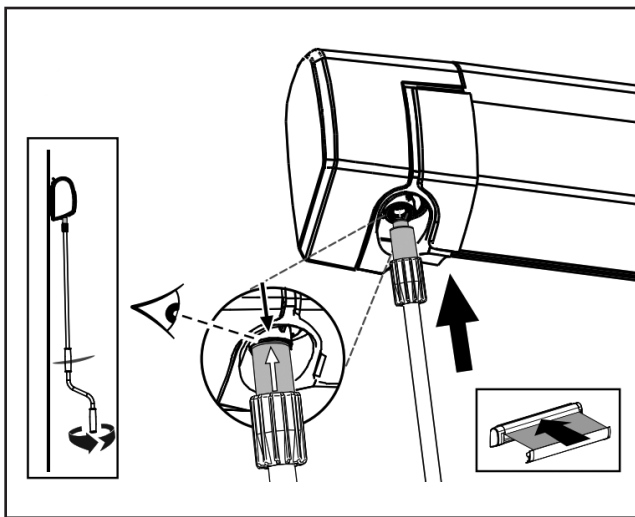

6. Contact your Dealer or an approved service facility to inspect the awning and resolve any issues if the awning failed to operate and the unit still had power.

#### **4. Maintenance of the Awning**

The Thule Owner's Manual does not call out maintenance instructions. That said, the awning fabric and components are comprised of similar materials to that of the Dometic main awnings and slide topper.

Please refer to the maintenance instructions for the main awnings or slide toppers for maintenance guidance.



---

---

---

---

---

---

---

---

---

---

---

---

---

---

---

---

---

---

---

---

---

---

---

---

---







# SEC.19 APPLIANCES

## A. GENERAL INFORMATION

Before using any appliance in the RV, it is best to read and understand all instructions, warning, and safety alerts provided within the manufacturer's manual of each appliance. These manuals can be found within your Owner Information Package.

If you happen to have additional questions or concerns, please do not hesitate to contact your Dealer or Brinkley RV Customer Care.

In the circumstance where aftermarket modifications have taken place within the RV, the provided instructions within this manual may not apply. In this occurrence, please contact the service center who performed the aftermarket installation for additional information and assistance.

## B. MICROWAVE

To utilize the microwave, sufficient 120-volt power **MUST** be available or the inverter must be used. To prevent damage, ensure the glass turntable within the microwave is properly secured before traveling. In RV's that do not have a range hood, the microwave vent is utilized in place of the range hood.



For additional information, please refer to the manufacturer's manual.

## C. 120-VOLT REFRIGERATOR

The refrigerator installed within your RV is 18.6 cubic feet (0.53 cubic meter), 120-volt refrigerator. For best cooling results, it is best to stock the freezer with already frozen foods and cold items within the main compartment.



- Stock the freezer with already frozen foods.
- Place chilled items in the cooling compartment.
- Arrange food so air can still circulate.
- Never cover the shelves with materials (i.e., cloth, paper, plastic, etc.).
- Keep the back section of the refrigerator clean and free of clutter, spills, and debris.
- Regularly have the refrigerator inspected and repaired as needed.
- At a minimum, the refrigerator should be inspected bi-annually.
- Repairs should always be performed by a certified or authorized service provider.

## REFRIGERATOR SECUREMENT

It is important to remember to always secure the refrigerator doors with the supplied velcro straps prior to travel. Failing to do so may result in damage to the refrigerator doors, loss of temperature and spoilage of food, and/or damage to the interior of the RV.



To utilize the travel securement, you will need to first wrap the velcro strap around the french door handles and ensure the grip on each end of the strap is secured to one another. Then, insert the second strap through the grommet on the first strap, around the freezer handle, and loop the receiving end of the second strap around the knob. Please see the photos below demonstrating how this is performed.



## D. COOKING WITH PROPANE

For LP safety instructions, please See [Section 20G](#) and the component manufacturer's manual.

### **⚠ DANGER**

**Never use portable fuel operated cooking equipment inside the RV (i.e., portable grills, stove tops, etc.). Use may lead to the build-up of carbon monoxide, inability to properly breathe, damage, personal injury, and fire.**

#### **IF YOU SMELL PROPANE:**

1. Extinguish all open flames, pilot lights, smoking materials, etc.
2. Refrain from touching any electrical switches.
3. Shut off the propane supply to the LP bottles.
4. Ventilate the RV by opening all doors, windows, and vents.
5. Remain at a safe distance from the RV until all odor clears.
6. Have the propane system inspected and repaired as needed before continuing use.

Failure to comply with these instructions may result in explosion of the RV leading to serious injury or death.

#### **Grease Fires**

Grease is highly flammable. Always clean the burners on your cooktop so grease does not collect on the surface or around the burner. If grease is spilled, clean it up immediately before continuing to cook. If a fire ignites, the instructions on the following page should be followed.

## IF THERE IS A GREASE FIRE:

1. Evacuate the RV immediately and make sure everyone is accounted for. Have everyone remain at a safe distance until the fire is extinguished.
2. Once everyone is at a safe distance, safely attempt to extinguish the fire.
  - a. First eliminate the fuel source by shutting off the oven or burner.
  - b. Attempt to smother the fire with a cooking lid.
  - c. Extinguish with baking soda or a multipurpose dry chemical extinguisher.
3. Never pick up a flaming pan. This can cause the fire to quickly spread if the pan is dropped or if the grease is spilled.
4. If the fire cannot be easily extinguished, your safety is priority. Immediately return to a safe location that is clear of the RV and call 911 to have the Fire Department handle the emergency.

## E. OUTDOOR COOKTOP (IF EQUIPPED)

The outdoor cooktop will only be found on select models, typically those with a bunk house.

### WHEN USING THE OUTDOOR COOKTOP:

- **NEVER** leave the cooktop unattended.
- Small children and pets should **ALWAYS** remain at a safe distance.
- **NEVER** store or place flammable materials or liquids near the lit cooktop.

After use: Allow the cooktop to fully cool prior to storing in the closed, travel position.

### ⚠ WARNING

**Never cover the vent openings on the oven while the cooktop is in operation. Restricting airflow will create an asphyxiation hazard.**

### ⚠ WARNING

**During and after use, while the burners are still hot, DO NOT touch or allow flammable materials to come in contact with the top burners, the burner grates, or any other surface that may be hot. Failure to do so may result in personal injury, damage, or fire.**

### ⚠ WARNING

**Before using the outdoor cooktop, the vehicle MUST be level and stabilized. All instructions and warnings within the manufacturer's manual must be followed at all times. Do not store the cooktop until it is fully cooled. Failure to follow these guidelines may lead to damage to the RV, fire, or explosion resulting in personal injury or death.**

## F. OVEN

The oven utilizes propane gas. Never store items in the oven, even when it is not in use. For additional information and warnings, please see the manufacturer's manual. Also See [Section 19H](#) below.

## G. RANGE HOOD (IF EQUIPPED)

The range hood has both a light and fan control switch on the front panel. The 8" x 8" (20.32 cm x 20.32 cm) aluminum mesh grease filter (located on the underside of the range hood) can be gently hand-washed using mild soap and water. In cases where there is no range hood, the microwave vent acts as the range hood.

### ⚠ WARNING

**NEVER leave cooking food unattended. Turn pan handles inward, but not over the tops of the other range burners. Ensure that pans used are large enough to contain the food and avoid boil-overs. Heavy splattering or spills left on the cooktop can ignite and cause burns.**



## H. RANGE TOP WITH OVEN

When selecting pan sizes, please refer to the manufacturer's recommendation. By following the recommended pot and pan sizes, you will improve cooking efficiency, lessen the risk of injury, and lessen the risk of damage. The pan should be large enough to cover the burner range, but no more than one inch larger than the burner grate itself.



### **⚠ DANGER**

**NEVER USE GAS OPERATED COOKING APPLIANCES IN ATTEMPT TO OBTAIN HEAT FOR COMFORT.** This form of use may lead to carbon monoxide poisoning, resulting in sickness, serious injury, or death.

### **⚠ WARNING**

Undersized pots and pans can cause a portion of the heating element to come in direct contact with the operator which may result in injury or ignition of clothing. Also, do not use cooking utensils that cover more than one burner at a time. Doing so will cause an accumulation of excess heat and may cause melting, soot buildup, and/or discoloration. There are specific utensils designed for the use on a top burner. Before cooking with ceramic, glass, or other glazed cooking utensils, verify they are safe for use.

## I. WASHER/DRYER PREP

Your RV is prepped for an aftermarket RV-rated washer/dryer (Customer Supplied) in two separate locations: the master bedroom and in the garage of the RV. A residential washer and dryer should never be used in a Brinkley RV.

Both washer/dryer prep locations are designed specifically for the stackable Splendide branded washer/dryer that is 23-1/2" (59.69 cm) wide. The ventless version is required for the garage prep.

### 1. Master Bedroom Prep

The first prep station is in the front cabinet just to the right of the closet in the master bedroom. Please know that this space is specifically designed for the installation of an aftermarket RV-rated washer/dryer. Please see the below photo.



## SEC.19 APPLIANCES

The clothes hanging rods and the shelves in this cabinet are removable to permit installation of the washer/dryer. Upon installation both will need to be fully removed. Below is a photo of the water connections in the master bedroom.

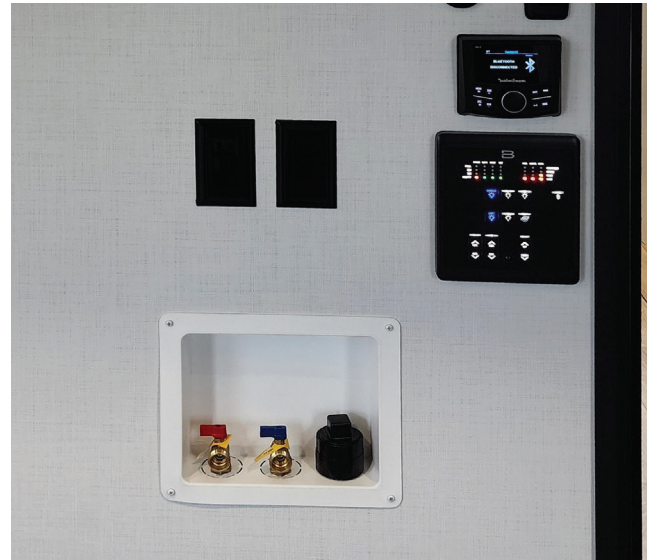

Because there is no exhaust for the dryer in the garage, if installed in this location, a ventless dryer **MUST** be used.

Please contact your Dealer or appliance manufacturer for additional information and installation assistance.

### 2. Garage Prep

The second prep station is in the rear portion of the RV in the garage. The water inlet is located near the garage monitor panel. This space is designed for an aftermarket RV-rated washer and a ventless RV-rated dryer. Please see the photo top right.



## A. GENERAL INFORMATION

The propane system within the RV includes all gas related appliances, propane cylinder(s), propane regulator, and all plumbing going to and from the LP cylinders to the appliances. Please see all the related manufacturer's manuals for additional information, instructions, and safety precautions.

### **⚠ DANGER**

**STOP IMMEDIATELY if you smell propane! Quickly and carefully perform the 6 steps provided in [Section 20C](#).**

## B. MAINTENANCE

Although the propane system is carefully inspected by both Brinkley RV and your selling Dealer, the propane system should continuously be inspected and repaired as needed. While in transit, fittings can loosen due to the vibration of the RV being towed or moved.

As a safety precaution, the RV's propane system should be inspected immediately upon purchase, after LP tanks are initially filled, and after the first 5,000 miles (8,046.72 km) traveled. Continuous LP inspections are part your normal RV maintenance and should be completed on an annual basis by your Dealer or a qualified service technician.

**DO NOT REMOVE THE FOLLOWING LABEL FROM YOUR RV:**

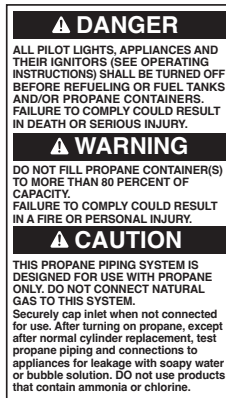

## C. PROPANE GAS

Propane (also referred to as LP) is widely used within your RV by appliances including, but not limited to, the stove, cooktop, furnace, and water heater.

Ethyl Mercaptan, an unpleasant chemical with the odor of "sulfur or rotten egg," is added to propane as a warning agent. Upon smelling this odor, it should alert you that LP is present and there is a possible leak creating a safety hazard.

When an LP tank is low in fuel, you will notice a different odor, one more like onion or garlic. As soon as the tank is refilled, this smell will dissipate. Commonly, this odor is mistaken as a gas leak. Be cautious of this and try to be aware of the different smells present with LP.

If you notice the odor persists, turn OFF all the gas operated appliances, shut the LP tank valves, and contact your Dealer or a qualified service facility to inspect the LP system.

### **⚠ DANGER**

#### **IF YOU SMELL PROPANE:**

- 1. Extinguish all open flames, pilot lights, smoking materials, etc.**
- 2. Refrain from touching any electrical switches.**
- 3. Shut off the propane supply at the LP bottles.**
- 4. Ventilate the RV by opening all doors, windows, and vents.**
- 5. Remain at a safe distance from the RV until all odor clears.**
- 6. Have the propane system inspected and repaired as needed before continuing use.**

**Failure to comply with these instructions may result in explosion of the RV leading to serious injury or death.**

# SEC.20 PROPANE (LP) SYSTEMS

## D. PROPANE GAS CYLINDERS

### 1. General Information

Propane cylinders, commonly referred to as LP bottles, are utilized for the storage and delivery of propane gas (LP) to the LP operated appliances within the RV. It is required for all propane cylinders to be filled at a qualified propane fill station and are filled by weight. While under pressure in the LP cylinder, the LP is in liquid form. As propane is released from the LP cylinder, it immediately transforms back into a gaseous state before reaching an appliance. The state of the LP is managed by an LP regulator found within 24 inches (60.96 cm) of the LP cylinder.

#### **⚠ DANGER**

**Propane EXPANDS 1.5% for every 10° F (5.56° C) increase in temperature.**

**Sufficient space within the LP cylinder must be left to allow for the expansion of gas during warmer weather. Failure to leave sufficient space may result in the cylinder exploding leading to property damage, RV damage, personal injury, or death.**

While the propane system is not in use, the propane cylinder valves MUST be closed to keep LP from being released. To fully shut off the LP, turn the valve found at the top of the propane cylinder clockwise. To open the LP valve, turn the valve counterclockwise. LP cylinder valves should always be hand tightened. Tools should never be used when opening or closing the LP cylinder valves. Over-tightening this valve may lead to damage of the internal seal which will cause them to improperly seat. If the seals are incapable of seating correctly, the valve will not be able to properly close and as a result will allow LP to bypass.

The LP cylinders provided with the RV are DOT (Department of Transportation) Cylinders. Every DOT cylinder is equipped with an overfill

protection device (OPD) and Acme Type 1 propane connector. Also, the valve can easily be identified by its triangular knob shape. Before traveling with or storing the RV, ensure this valve is fully closed on the tank.



LP VALVE



ACME TYPE 1  
PROPANE CONNECTOR

When removing the cylinders to fill, always reinstall them in the proper orientation. Typically, DOT cylinders have an arrow and label signifying “top” to indicate the correct orientation of how the cylinder(s) should be installed.

#### **+ NOTICE**

LP cylinders should always be mounted, stored, and transported in the correct specified position. They should be securely fastened using the straps provided by Brinkley RV.

Each LP cylinder is connected by a thermal Type 1 Acme Pigtail. You will also find a two-stage regulator to monitor the pressure of LP released. The pigtail assembly is a wrenchless system and should only be hand tightened when needed.



TYPE 1 ACME PIGTAIL

**⚠ WARNING**

Because propane can quickly expand, a pressure release valve is installed on the cylinder so that gas can discharge as pressure builds. If gas is discharged, it will be released into the surrounding environment. Propane cylinders should never be stored indoors or inside the RV.

**2. Servicing or Filling**

Upon purchasing the RV and as the tanks are filled, the propane system should be inspected for leaks.

**⚠ WARNING**

**When filling tanks, only the qualified service representative should be near the RV. Make sure all parties are at a safe distance and not within the RV.**

When an LP cylinder is being filled for the first time, make sure a qualified representative purges the cylinder of any trapped air. If the cylinder is not purged, an imbalanced mixture of air and gas may occur making it impossible for propane appliances to light.

**⚠ WARNING**

**PRIOR TO arriving at a propane fill station, be sure all pilot lights are fully extinguished and all LP appliances are shut off. Always turn off the engine of the tow vehicle before fueling. Never smoke or operate other ignition sources while fueling.**

**3. LP Gas Container Overfill****⚠ WARNING**

If you suspect an LP Cylinder has been over-filled, remain at a safe distance and contact your Dealer or a qualified propane technician immediately for assistance. Never attempt to service an over-filled LP cylinder.

**4. Propane Leak Test**

Test for leaks with a water and soap solution

**TESTING FOR LP LEAKS:**

- Mix the solution and spray all joints and fittings of the gas line.
- When a leak is present, the soapy solution will bubble.
- Small bubbles tend to indicate smaller leaks and larger bubbles indicate larger leaks. Neither should be ignored.

If a leak is present and is not corrected by tightening the connection, shut off all LP and LP appliances and contact your Dealer immediately.

**+ NOTICE**

Never use an ammonia or chlorine-based solution. Both can cause corrosive damage to the gas lines and fittings.

**⚠ WARNING**

**Never use an open flame to test for leaks. Doing so may result in fire or explosion leading to serious damage, injury, or death.**

# SEC.20 PROPANE (LP) SYSTEMS

## 5. Propane Gas Alarm

Each RV is equipped with a Propane Gas Alarm. Please See [Section 4G](#) for additional details. Please also refer to the manufacturer's manual.

## 6. Installing the Propane Cylinders

Correct positioning of the LP cylinder(s) and all related hoses and fittings is vital for the proper operation and flow of propane.

### INSTALLING LP CYLINDERS:

1. **ENSURE** all fuel fed appliances are shut **OFF**.
2. **ENSURE** the LP cylinder valve is **CLOSED**.
3. **CONNECT** the 3/8" low-pressure hose to the inlet of the two-stage regulator.
4. **PLACE** the LP cylinder on the LP bracket in the designated compartment and secure the tank in place using the provided straps.
5. **MOUNT** the regulator on the back wall centered to the compartment so the vent is pointing downward.
6. **ATTACH** the Type-1 pigtail hose to the regulator and hand tighten.
7. **ATTACH** the main supply hose from the regulator to the brass manifold fitting in the frame of the RV. The swivel brass nut on the main hose will be your final attachment.

### **⚠ DANGER**

The Propane Gas Alarm should be tested before every use of the RV and at least once a week throughout the trip.

### **⚠ WARNING**

Never remove power from the alarms to silence them.

### **⚠ WARNING**

To prevent tension and strain, a 12-18" (30.48-45.72 cm) Type 1 Acme Pigtail must be installed. Keep the pigtail hose free and clear from sharp edges and objects.

### REINSTALLING AN LP CYLINDER:

- Inspect and tighten fittings as needed. Use the soap and water solution to test.
- Slowly open the main shut-off valve on the LP cylinder to prevent the propane from freezing up.
- If the propane freezes up, immediately close the main LP valve and wait at least fifteen (15) minutes before attempting a second time. For more information, please refer to the regulator manufacturer's manual.
- Listen for a hissing sound as the main valve is opened. If this sound last longer than a second, quickly shut the valve. This is an indication that there may be a leak. If you suspect a leak and it cannot be found, contact your Dealer or a certified service location for assistance.
- **REINSTALL** all protective covers and caps that were removed from the LP system.

### **⚠ WARNING**

Ensure that all fasteners and safety straps are secured before traveling.

## E. PROPANE REGULATOR

Installed within the LP compartment on the off door side, or driver side, is a dual two-stage automatic regulator. The purpose of this regulator is to reduce the pressure of the LP coming from the LP cylinders to a consistent and safe pressure as well as allow the convenience of switching from one LP cylinder to the reserve LP cylinder when empty.

The first stage of the regulator reduces the LP pressure down to 5-10 psi (34.5-68.9 kPa). The second stage of the regulator further reduces the pressure to an operating pressure of 11" (27.94 cm)W.C. (water column).

For efficient performance, the second stage of the regulator should be adjusted by your Dealer or qualified service representative using a calibrated manometer.

- When the pressure is too high, safety and performance will be affected within the LP system.
- When pressure is too low, the operation of the LP appliances will be affected and may not operate or operate correctly.

If your RV contains an automatic two-stage regulator and both LP cylinders are full, turn the lever found on the regulator towards the LP cylinder you would like to use first. The chosen LP cylinder will be the primary tank utilized and the other will be the reserve.

Once the primary LP cylinder is determined with the regulator lever, slowly open the LP cylinder valve. The indicator found at the top of the regulator will change to green as the LP makes its way to the regulator. Once the primary LP cylinder becomes empty, as long as the reserve cylinder valve is open, the regulator will slowly begin to pull from the reserve tank. At this point, the indicator will show red signaling that the cylinder the lever is facing, is empty. At this time, the regulator lever should be switched over to the

reserve LP cylinder. The indicator will turn green as the LP supply increases in pressure. At this point, the empty LP cylinder can be removed and filled without interrupting the flow of LP from the reserve cylinder.



After the LP cylinder is refilled, remember to reconnect the pigtail line and secure the LP cylinder with the provided straps. If you would like notice before the regulator begins to pull from this cylinder, leave the valve closed. This will prevent the regulator from switching to the opposing LP cylinder without notice.

### + NOTICE

When the indicator on the LP regulator is RED, the LP tank is empty. If the indicator is BLACK, LP is still being supplied.

### ⚠ WARNING

**Vibration from travel can cause fittings to loosen over time. Frequently inspect the LP system for leaks and loose fittings. Failure to inspect the LP system may lead to gas leak resulting in fire or explosion.**



### **⚠ WARNING**

When a two-stage propane regulator is installed, it must be installed with the regulator vent facing down. Regulators found outside of the storage compartment are equipped with a protective cover. These regulators must also be installed with the vent facing down and the cover must remain in place to help minimize the possibility of the vent becoming blocked. If these instructions are not followed, vents may lose their efficiency or become obstructed leading to the buildup of excessive gas pressure and may cause fire or explosion.

### F. PROPANE SYSTEM HOSES, TUBES, PIPES, AND FITTINGS

The hoses, pipes, tubes, and fittings that comprise the propane system are designed to handle pressures exceeding what the overall propane system is designed and intended to handle. The purpose of this is to provide additional safety within the overall LP system.

Because components will deteriorate over time, particularly when exposed to the elements, all components should be continuously inspected for wear and tear as suggested. LP hoses should be inspected prior to every use for cracks, durability, and flexibility. If cracks are present or durability and flexibility has been lost on the line, refrain from using the LP system until the line can be replaced.

When replacing an LP line or component, do so with components of the same nature, type, and rating. Never replace components with substitutions not suitable for the LP system. Always verify components with your Dealer if you are not sure.

The fittings utilized within the LP system connect all the various components found within the system. The fitting found at the end of the propane supply hose is made of brass and is known as a POL fitting. The threads within the fitting are

left-handed threads which means you would turn counterclockwise to tighten, and clockwise to loosen. The nature of this fitting allows it to prevent leaks from occurring without the use of pipe sealant and is designed to reduce the flow of LP in the event the regulator fails or hose malfunctions.

### G. COOKING WITH PROPANE

Because an RV is much smaller than a typical house, oxygen within the RV is limited. Any time a LP appliance is used within the RV, such as a cooking appliance, the RV should be properly ventilated to avoid the danger of asphyxiation. For additional safety instructions and information please See [Section 19](#).

### H. TRAVELING WITH PROPANE

#### **PRIOR TO TOWING THE RV:**

1. **ENSURE** the propane cylinders are properly seated and fastened with the supplied straps.
2. **SHUT OFF** all LP fueled appliances.
3. **CLOSE** the valve found at the top of the LP cylinder.

Make sure you know the local laws regarding LP systems and transportation. State laws vary depending on location (i.e., tunnel and bridge laws when traveling with LP). Know this information before traveling in that given state.

### **⚠ WARNING**

**NEVER** operate the propane system while the RV is in motion. Unpredictable weather conditions may pose great threat to the LP system if the provided instructions are not followed. For example, wind currents may cause flame reversal in the water heater or cooking appliance which could lead to fire or explosion.

## I. OPERATING THE PROPANE SYSTEM

Once the RV is fully set up and prepared for camping, please refer to the following steps for proper operation of the LP system.

### OPERATING THE LP SYSTEM:

1. **ENSURE** all burners, controls, and pilot lights are shut off.
2. **OPEN** the main valve on the LP cylinder **SLOWLY** to prevent an LP freeze-up from occurring. If a propane freeze-up occurs, immediately close the valve and wait at least 15 minutes and then try again.
3. **LISTEN** carefully as you open the valve and as propane begins to flow. If the hissing sound of LP rushing through the lines lasts more than a second or two, quickly shut the main valve and contact your Dealer. In this occurrence, most likely there is a leak.
4. **OPERATE** the LP appliances **ONLY** as directed in the appropriate manufacturer's manual.

### + NOTICE

**About LP Freeze Ups:** As the liquid propane expands to a gas form and reaches its boiling point, it commonly freezes the available humidity around the regulator. This form of freezing isn't cause for concern. However, in extremely rare cases, the propane can "freeze" and remain in a liquid state as it passes through the regulator.

Prior to operating the propane system, please read and understand all instructions, safety requirements, warnings, and labels found within

this document and the provided manufacturer's manuals found within the Owner Information Package.

If you have additional questions or concerns, please contact your Dealer, the component manufacturer, or Brinkley RV Customer Care.

## J. CALCULATING PROPANE USE

To determine how long the propane supply will last on your RV, use the BTU rating for each LP appliance. Propane consumption will vary depending on the length of use and the BTU used by the component. To calculate supply, take the BTU remaining in the LP cylinder divided by the BTU of the given appliance.

As reference, each gallon of propane (3.79 liters) produces roughly 91,500 BTUs of heat energy. If the furnace uses 16,400 BTU/Hr. and the LP cylinder has one gallon of propane, the calculation would be as follows: (91,500 BTU)/(16,400 BTU) = approximately 5-½ hours of use.

$$\text{(Gallons of Propane x 91,500 BTU) / Appliance BTU = Supply of BTU in Hours.}$$

Many of the LP appliances operate intermittently to prevent over-consumption of fuel. For example, unless the water heater is heavily used, the consumption of LP by the water heater is minimal. Be aware that cold weather and high winds can increase LP consumption of the gas appliances.

| APPLIANCE            | AVERAGE BTU CONSUMPTION/HR.          |
|----------------------|--------------------------------------|
| WATER HEATER         | 60,000 (RUNNING WATER THE WHOLE HR.) |
| FURNACE              | 35,000                               |
| RANGE W/OVEN         | 7,100                                |
| RANGE – REAR BURNER  | 6,500                                |
| RANGE – FRONT BURNER | 9,000                                |

# SEC.21 PLUMBING SYSTEMS

## A. INTRODUCTION

There are two water systems provided in the RV:

1. The Fresh Water System.
2. The Wastewater System.

### The Fresh Water System

includes the freshwater holding tank(s), freshwater PEX lines and fittings, water heater, water pump, exterior spray ports, faucets, and water purification system (If Equipped).

### The Wastewater System

consists of the gray and black water holding tanks, drains, drain lines, and toilet.

Prior to each trip and before the RV is stored, the following items should be inspected for leaks:

- All fresh and wastewater system lines and fittings.
- All faucet connections and its draining system.
- The water pump and water heater plumbing and connections.

At the end of each trip, the fresh tank should be drained and the waste tanks, both gray and black, should be properly emptied.

DO NOT REMOVE THE FOLLOWING LABEL FROM YOUR RV:

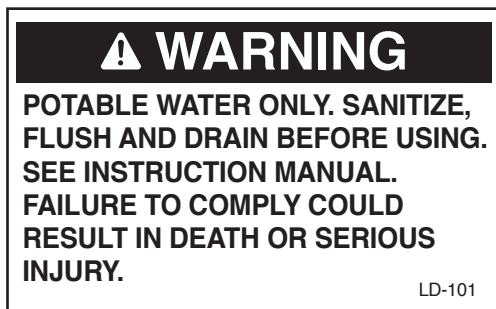

## ⚠ WARNING

**Do not drink or consume water of unknown quality or that is deemed unsanitary or unsafe.**

## B. FIRST USE OF THE FRESH WATER SYSTEM

If your RV has been winterized from the factory, there will be a label placed on the entry door signifying **“This Unit Has Been Winterized.”**

WINTERIZATION LABEL:



Even if the RV has not been winterized, the water system should be sanitized prior to the first use. Sanitizing the water system in the RV will kill unwanted bacteria and organisms that may contaminate the water supply.

Please know that small amounts of contaminants and minerals are found in all water supplies. Even small amounts of contaminants can cause the freshwater to have an odor over time.

Please See [Section 21N](#) on how to sanitize the Fresh Water system.

## C. TANK MONITORING

There are three ways to monitor the fill levels of the black, grey, and fresh water holding tanks:

1. The Monitor Panel.
2. OneControl Touch Panel (OCTP).
3. The OneControl App.

## The Monitor Panel

can be located in the garage area of the RV. This monitor panel contains many controls for the garage lights, water pump, awning, bed lift, and will display the fill levels of the fresh, gray, and black water holding tanks.



The red circled portion of the monitor panel shown above indicates the holding tank level information. In addition, it also will display voltage of the auxiliary battery. The battery charge information is shown on the portion of the panel circled in blue.

The monitor panel operates on 12-volt power that can be either supplied by the auxiliary battery or by the converter. No power is drawn from the battery unless a button is pushed to wake up the panel. Fuses for the monitor panel are in the load center.

## The OneControl Touch Panel (OCTP)

is located just inside the main entry door in the hallway leading to the bedroom and bathroom. This system provides control to many of the functions within the RV such as your slides, heating, cooling, lights, fuel, battery voltage, etc., while also providing fill levels of all holding tanks on your RV. The tank monitoring screen looks similar to the photo above right.



Circled in red, you will see the portion of the screen displaying the monitoring section for the tanks. The OCTP is hard wired into the RV and is powered by the 12-volt system. If the OCTP goes into sleep mode, you can wake it by pressing the button located just to the bottom of the panel. Please See [Section 16](#) for more detail on OneControl.

## The OneControl App

is very similar to the functionality of the One Control Touch Panel but can be downloaded and used on your cellular device. Please see [Section 16](#) for more detail on OneControl app.

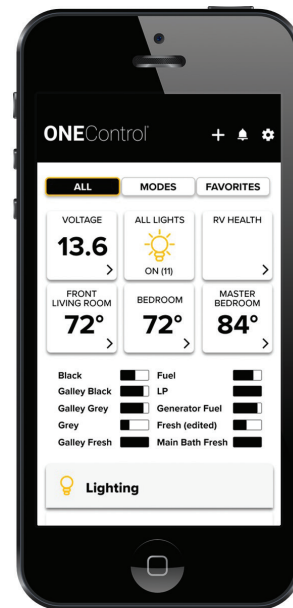

## SEC.21 PLUMBING SYSTEMS

### D. WATER PRESSURE REGULATOR (CUSTOMER SUPPLIED)

Some RV parks, especially those in mountainous regions, have excessive water pressures that exceed the pressure limits of what the RV water system is capable of handling. If the RV is not properly protected, the water system can be compromised and/or damaged. To prevent damages, it is recommended you purchase a water pressure regulator. This is a Customer Supplied item and can be purchased through your Dealer.

#### + NOTICE

Excessive water pressures may cause the O-rings within the water system to fail if a water pressure regulator is not used. It is recommended for a water pressure regulator rated at 45 psi (310.3 kPa) be utilized when filling with or otherwise utilizing city water. This is a Customer Supplied item and is not supplied with the RV.

### E. WATER PUMP SWITCH

The water pump can be turned on by the monitor panel, the OCTP, or through the OneControl app. Once the water pump is turned ON, it will run until there is 45 psi (310.3 kPa) within the waterlines. Once the pump achieves a pressure of 45 psi (310.3 kPa) it will automatically shut off. The water pump is an on-demand pump and will run anytime the pressure in drops below 45 psi (310.3 kPa).

### F. 12-VOLT WATER PUMP

The water pump is located in the pass-through storage compartment behind the access panel and behind the filtration system. Once the on-demand water pump is activated, it will self-prime and provide water. It will continue to run even after the water is shut off until it builds approximately 45 psi (310.3 kPa) of pressure within the waterlines. The water pump contains a built-in check valve that will not allow water to back flow and will automatically

restart if pressures drop within the water lines. The water pump filter (If Equipped) is a reusable screen-type filter that is located on the inlet side of the fill. This filter should be periodically cleaned as needed.

#### + NOTICE

When filling the fresh holding tank, do so with caution and DO NOT leave the tank unattended while filling. It is important to never overfill the tank. When a tank is overfilled, it causes excess pressure to build within the tank that may lead to leaks and water damage. Such damages are not warrantable and can be costly.

### G. WATER FILTRATION SYSTEM

Just before the water reaches the 12-volt water pump, the water is filtered through a triple stage filtration system. The purpose of this filtration system is to remove unwanted containments such as iron and sulfur while also removing possible smells from the harsh water found at many campgrounds. This filtration system is located in the pass-through storage compartment, behind the collapsible access panel, near the water pump. Below, is a photo showing the system and its location.





The maximum flow rate for the for triple stage filtration system is 2.5 gallons per minute (9.46 liters per minute) at 60 psi (413.7 kPa). Because the rating for the water pump is 45 psi (310.3 kPa) and less than the available rating of the filtration system, only 45 psi (310.3 kPa) should be used.

## H. FRESH WATER HOLDING TANK

To fill the freshwater tank, do so using the freshwater inlet referred to as the city water inlet. The picture (below) shows the city water inlet.



Under the RV, you will notice plastic overflow tubes that are directly plumbed into the freshwater tank. See picture, below.



The purpose of these lines is to alleviate pressure as it is built within the tank, or to prevent the tank from overflowing when being filled. On occasion, you may see water being expelled from these lines if the tank is overfilled, the RV is parked on an incline, or when from stopping and starting while traveling. This is normal and should not pose a concern.

- **NEVER** block, cap, or modify the overflow tubes in any way.
- When the overflow tubes become obstructed, water pressure can build while filling and can cause damage to the plumbing system.

### + NOTICE

Freshwater supply should be disconnected when the RV is left unattended for extended periods of time. This will limit the damages if there are leaks within the water system.

# SEC.21 PLUMBING SYSTEMS

## I. WATER HEATER—TANKLESS

### 1. General

Before using the hot water heater, please read all safety and operating instructions, information, and warnings provided within this manual and the manufacturer's manual. The tankless hot water heater installed within the RV is an on-demand water heater. As hot water is used, the tankless water heater will heat incoming cold water through a coil system. This temperature is regulated by an internal sensor over a large heat exchanger. This design allows the hot water heater to operate with energy efficiency unlike most conventional tank water heaters that require constant energy during the re-heat cycles. Following is a photo of the front cover plate of the water heater.



### 2. Controller Operation



Before normal operation of the appliance, perform a basic functional test each time the RV and water system is set up for use. Refer to “Initial Startup” of the component manufacturer’s manual for instruction. After the functional test is completed, the appliance can be operated from the controller located under the main bathroom sink. A photo is shown above right.



- Touch the power button to turn the power **ON/OFF**. Upon pressing the power button, the panel and screen will illuminate and display the current temperature setting.

#### + NOTICE

The microprocessor is always on. It draws approximately 0.25 amps.

- Touch button marked “F/°C” to transform the temperature display in °F or °C, the related LED would be lighted on the controller.
- Touch the  or  button to adjust the temperature to your desired settings. The wall controller settings range from 95° F (35° C) to 123° F (51° C).

### 3. Safe Operation

#### **⚠ WARNING**

Gas combustion consumes a large amount of air and generates hot exhaust gases including carbon monoxide as the appliance works. Harm or even death may be caused by inhalation of excessive carbon monoxide.

---

Consider the following points for safe use of the appliance:

- Install an RV water regulator to the inlet of the RV and operate no higher than 45 psi (310.3 kPa).
- The factory default water temperature setting is 115° F (46° C) but can operate between the temperature range of 95° F to 123° F (35° C to 51° C).
- There may be a variation between the temperature delivered from the appliance and the temperature at the faucet due to variance in local ground water, ambient temperatures, or the length of pipe from the appliance.
- **NEVER** use this appliance in enclosed spaces or tents.
- **ALWAYS** turn the appliance off, and shut off fuel supply while parking the RV in an enclosed space, such as a garage or repair shop.
- **NEVER** place seating, picnic tables, awnings, or canopies in a direct path of the exhaust outlet.
- **DO NOT** use this water heater without a working carbon monoxide detector installed in the RV.
- **ALWAYS** keep the air inlet and exhaust outlet free of obstructions in order to ensure clean combustion.
- **DO NOT** place articles on or against the appliance.
- **DO NOT** lean any objects against the water heater's access door or place any foreign objects within 24" (610 mm) of the access door.

- **DO NOT** use or store flammable materials near the appliance.
- **DO NOT** spray aerosols in the vicinity of the appliance while it is in operation.
- **DO NOT** modify the appliance.

#### **⚠ WARNING**

**SCALD HAZARD: Never allow infants or children to adjust the water temperature or be left unsupervised when using hot water. Tankless water heaters adjust quickly and may lead to serious injury if not properly used.**

---

#### **⚠ WARNING**

**Never store gasoline or other fuel sources near this appliance.**

---

#### **⚠ WARNING**

**The hot water heater must be operated in the manner intended and with the instruction provided by the manufacturer. Failure to follow these instructions may lead to serious injury, fire, or explosion, property damage or death.**

---

### 4. Water Control

The CPU chip of the system automatically sets the optimal operation parameters for the appliance according to the bathing environment data such as water volume, ambient water temperature, gas pressure, and the desired hot water temperature.

### 5. High Altitude Use

This appliance can be used at high altitude and has been tested up to 4500 feet (1371.6 m). For prolonged use at higher altitudes please contact the support team at RVMP at (855) HAPPYRV for recommendation and assistance.

## 6. Storage and Transit

Anytime the RV is not intended to be used, it is considered to be in storage or transit.

To prepare the water heater, follow the below steps:

- a. Turn off gas supply.
- b. Turn off the electric power supply.
- c. If freezing conditions occur (ambient temperature less than 39° F (4° C)):
  1. Remove all water from the water heater and optionally install RV non-toxic antifreeze, or
  2. Utilize the water heater's automated warming system by leaving the gas supply on as well as the electric power switch located on the heater unit. This should only be done if the RV is being stored and is not left unattended. This should not be done when the RV is in transit.

### + NOTICE

The power and the gas supply **MUST** remain ON for the automated warming feature to be used. If this option is used, the RV should not be left unattended.

## 7. Operating in Freezing Temperatures

This water heater is equipped with an automated warming system for use in cold weather conditions. The purpose of this system is to keep the water heater from freezing when the RV is used in conditions where the ambient air is near the freezing temperature of water, and thus prevents water in the unit from freezing.

There is a bi-metallic cold weather thermostat located on the hot water line. This cold weather thermostat is designed to turn on the burner at 35° F (1.6° C) and turn off the burner at 48° F (8.88° C). The control board will keep the burner on until the thermostat turns off when the temperature on the water line reaches 48° F (8.88° C).

At this point the flame should turn off immediately and the fan will turn off 30 seconds later. When the system operates with the warming system an "Fd" code will show on the UCP. Fd: Warming cold weather thermostat has engaged and turned on the burner of the water heater.

## 8. Routine Inspection

Routine inspection is critical for maintaining proper operation of your appliance. Unless specified, review the following items annually or before each season:

- a. Inspect for cracks, separation, and peeling between the main shroud of the water heater and the RV wall. Remove and re-seal as necessary (Brinkley RV uses automotive grade tape) between the side wall and the door of the water heater and ensure that the unit is solidly mounted to the vehicle.
- b. Verify that the air inlet openings (louvers) are completely open and clear of any debris including mud, leaves, twigs, insects, etc.
- c. Insects, including wasps and spiders, can build nests in the exhaust tube outlet which will affect the performance of the unit. Inspect the flue outlet tube to make sure that it is unobstructed and that the screen is clean. If debris or insects are present, clean, and vacuum to remove any remaining debris. The use of any type of after-market screen to cover the vent is not permitted and will void the warranty.



- d. Open the door and verify that no debris or extraneous combustible materials are present anywhere (especially in the burner and the gas controls). Remove any item present and wipe clean the bottom of the housing.
- e. Inspect the interior surface of the housing for any cracks or corroded areas that could allow penetration of gases into or out of the interior of the vehicle. Check especially around the hot water, cold water, gas and electrical connections.

#### + NOTICE

If damage is found, please contact a technician to repair or contact RVMP Customer Service.

- f. Check that all wire connections are firmly in place and there are no signs of chafing or cracks on the insulation. Verify that the spark ignition cable between the Control Board and the igniter is securely in place and not shorted to any metal component.
- g. Inspect/clean/replace the water inlet filter as necessary.

#### ⚠ WARNING

##### **BURN OR SCALD HAZARD:**

- **NEVER** drain the hot water heater while hot.
- **NEVER** perform work on the water heater while it is operating.
- **NEVER** perform work unless the Electrical and LP gas supply is shut off.
- **NEVER** perform work while the appliance is hot.
- **NEVER** actuate the pressure relief valve if the appliance is still hot.

## 9. Hard Water Treatment

Prolonged usage with hard inlet water can result in buildup in the appliance and eventual damage or failure. When exposed to higher water hardness concentrations, it is advised to provide a proper water treatment device for the incoming water to the RV. Hard water may lead to performance reduction of your appliance over time.

Contact RVMP for decalcification instructions [support@rvmp.com](mailto:support@rvmp.com).

#### + NOTICE

**Hard Water and Decalcification:**  
 For prolonged usage, when exposed to higher water hardness concentrations, it is advised to provide a water softening device for the incoming water to the RV. Hard water may lead to performance reduction of your appliance over time. Contact RVMP for decalcification instructions.



# SEC.21 PLUMBING SYSTEMS

## J. BATHROOM SHOWER

### 1. General

Unlike a household, the RV does not contain a water pressure balance valve. Refrain from running other water sources while the shower is in use. Air may need to be purged from the lines before a steady stream can flow.

- Always be aware of the holding tank capacities. Water that is used will drain directly into the gray holding tank and can back up when full.
- Turn the water heater **ON** and allow the coils to heat.
- If dry camping, the water pump will need to be turned **ON**.
- Adjust the hot and cold temperatures with the faucet knob. Make sure the desired temperature is achieved **BEFORE** entering the shower.
- To conserve water, wet down and turn **OFF** the water supply while washing. Then, turn **ON** to rinse.
- When finished, shut **OFF** the knobs to the hot and cold water.

### + NOTICE

There is no shut-off valve at the shower head. Water must be shut OFF using the knobs on the faucet. Once water is shut OFF, water may slightly drip from the shower head. This is normal and is NOT an indication of a leak.

### 2. Maintenance

The shower walls within the RV are made of fiberglass and should be cleaned with a mild dish soap and water solution only. **DO NOT** use abrasive or harsh chemicals, compounds, or soaps when cleaning the shower.

### 3. Shower Door

Your RV is equipped with a glass shower door. The door has three (3) individual panes of glass that make up the door. These 3 panes of glass slide side to side in the shower door extrusions to permit ingress and egress into the shower. It is important to ensure that the travel latch on the shower door is properly latched prior to travel. Depending on the bathroom layout, the latch could be located on the interior or exterior of the door. In the picture provided below, the travel latch is located on the interior of the shower door.



### OPERATING THE SHOWER LATCH:

1. To open, rotate the latch upward to release the door from its travel latched position.



2. To close, rotate the latch down until it is fully seated around the knob. You should feel it snap into place when it is properly seated.



### ⚠ CAUTION

It is very important that you properly stow the shower door for travel as indicated by the above-provided instructions. Failure to latch the shower door in its travel position will likely lead to the shower door glass shattering in transit. This is a common occurrence as people tend to forget this step before towing the RV. A shower door with shattered glass is not covered by either the Brinkley RV or the shower door manufacturer's warranties.

### K. FAUCETS

The faucets installed within the RV operate much like those in your home.

- Make sure there is a sufficient water supply.
- Turn **ON** the water pump if dry camping.
- Turn **ON** the water supply at the faucet and adjust temperature.
- Turn off when finished.

### L. EXTERIOR SPRAY PORTS

There are two (2) exterior sprays parts on your Brinkley RV.

The first spray port is located on the convenience center found within the pass-through storage compartment on the off door (driver) side of the RV. The below photo shows the convenience center and the location of this spray port.



## SEC.21 PLUMBING SYSTEMS

The second spray port is located on the wall of the pass-through storage on the door (passenger) side of the RV. The below photo shows the spray port and its location.



### OPERATING THE SPRAY PORTS:

1. **ATTACH** the supplied quick-connect hose and sprayer to the spray port found at the convenience center.
2. Ensure the tankless hot water heater is turned **ON** if you desire hot water at the external spray ports.
3. When dry camping, turn **ON** the water pump.
4. Turn **ON** the hot and cold water using the knobs and adjust the temperature accordingly.

### WHEN FINISHED:

1. Turn **OFF** the hot and cold water using the knobs.
2. **DISCONNECT** the quick-connect sprayer and allow excess water to drain.

## M. UNIVERSAL DOCKING CONVENIENCE CENTER—THE NAUTILUS P4-3 PANEL

### 1. General

Your Brinkley RV is equipped with a Universal Docking Convenience Center (referred to as “convenience center” throughout this manual). It is called the Nautilus P4-3 Handle system. The instructions on how to utilize the convenience center is covered in detail in the paragraphs that follow.



### + NOTICE

**IMPORTANT – NEVER** push the check valve on the “CITY WATER” connection with pressure in line. This will cause irreparable damage to the check valve function. See the picture below for location of the check valve on the city water connection.





**THE NAUTILUS P4 PANEL SYSTEM WILL ALLOW YOU TO PERFORM THE FOLLOWING FUNCTIONS:**

1. Power fill your fresh water tank for remote or dry camping.
2. Use your water pump to supply water to fixtures from the freshwater tank.
3. Use your water pump to siphon fill or sanitize your freshwater tank from a bucket.
4. Connect to city water at the camping site to supply water to the fixtures.
5. Winterize your plumbing lines and fixtures.
6. Rinse the black tank to help control odors and prevent sewage buildup.
7. Rinse off items outside the unit with a hot or cold faucet.
8. Connect coax lines with satellite, cable, and auxiliary.

**2. Handle Position and Valve Routing Information**

**WHITE HANDLE:**

Receives water from water inlet on front of panel.

**Sideways**—water goes to pump inlet.



**Down**—water goes into blue handle.



**BLUE HANDLE:**

Receives water from the white handle valve/water inlet on front of panel.

**Sideways**—water goes to fixtures (cold).

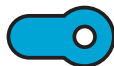

**Down**—water will go to or come from fresh water tank.



**GREEN HANDLE:**

Is an on/off through valve that feeds the pump from the fresh water tank.

**Sideways**—water will not flow through valve.



**Up**—water will go to or come from fresh water tank.



**3. Fresh Water Tank PowerFILL**

1. Connect garden hose to inlet labeled "**CITY WATER**".
2. Turn handles to "**PowerFILL Tank**" position as shown.
  - **BLUE** diverter handle should be facing down.
  - **WHITE** diverter handle should be facing down.
  - **GREEN** diverter handle should be facing left.



3. Connect other end of hose to water supply source.

## SEC.21 PLUMBING SYSTEMS



4. Turn water supply on at source.  
Fresh water tank should begin to fill.

### + NOTICE

Consult the specifications of your specific RV for tank capacities. Do not overfill tank.



5. When desired level in fresh water tank is reached, turn water off at source.
6. Disconnect garden hose from inlet on Nautilus panel.

### 4. Sanitizing the Fresh Water Tank—"Sanitize"

1. Connect garden hose to inlet labeled "CITY WATER".
2. Turn handles to "SIPHON" position as shown.
  - **BLUE** diverter handle should be facing down.
  - **WHITE** diverter handle should be facing right.
  - **GREEN** diverter handle should be facing left.



3. Place other end of hose in container holding water or sanitizing solution.





4. Push **"PUMP"** switch to turn on pump.



**+ NOTICE**

LED indicator light below the pump switch will be lit if pump has power.

5. Pump should be running and fresh water tank should begin to fill.

**+ NOTICE**

Consult the specifications of your specific RV for tank capacities. Do not overfill tank.

6. When desired level in fresh water tank is reached, push **"PUMP"** switch to turn pump off.

**+ NOTICE**

LED indicator light below the pump switch will not be lit.



7. Disconnect garden hose from inlet on Nautilus panel.

**5. Fresh Tank Supply—"Dry Camping"**

1. Make sure fresh water tank has necessary supply of water.

2 Turn handles to **"DRY CAMPING"** position as shown.

- **BLUE** diverter handle should be facing left.
- **WHITE** diverter handle should be facing down.
- **GREEN** diverter handle should be facing up.



# SEC.21 PLUMBING SYSTEMS

3. Flip "PUMP" switch to turn pump on.

### + NOTICE

LED indicator light below the pump switch will be lit if pump has power.

4. Water should be available to all fixtures.

### + NOTICE

The pump will run when a plumbing fixture is open.

5. Make sure pump is turned off when not in use.

## 6. Utilizing a Pressurized Water Source— "City Water"

1. Connect garden hose to inlet "CITY WATER"
2. Turn handles to "CITY WATER" position.
  - **BLUE** diverter handle should be facing left.
  - **WHITE** diverter handle should be facing down.
  - **GREEN** diverter handle should be facing left.



3. Connect other end of hose to water supply.



4. Open faucet at water supply source.  
Water should be available to all fixtures.

### + NOTICE

Water pressures should remain under 45 psi (310.3 kPa)

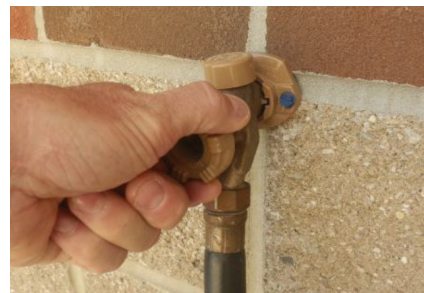

Over pressurizing water lines may cause damage to plumbing lines and fixtures.

## 7. Rinsing the Waste Tank—"Tank Flush"

1. Connect flexible sewer hose to 4" (10.16 cm) dump outlet on unit.



2. Open black waste holding tank and leave open to allow black tank to drain.



3. Attach a garden hose to inlet labeled **“TANK FLUSH”**.



**+ NOTICE**

The diverter handle does not need to be in a specific sequence during this operation/process.

4. Connect other end of hose to water supply source.



5. Fully open faucet at water supply source (40 psi minimum, 275.8 kPa). Flush tank until water appears clear in 4" (10.16 cm) discharge hose.



6. Completely close faucet at water supply source.

7. Disconnect garden hose from water source.

8. Disconnect garden hose from **“TANK FLUSH”** inlet.

9. Close black waste holding tank valve.

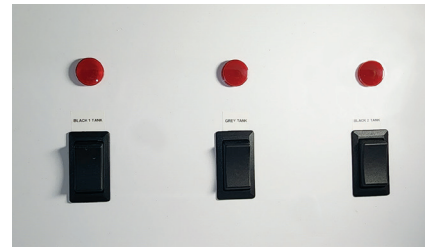

**+ NOTICE**

The images provided pertaining to the convenience center panel are provided for illustrative purposes only. They do not necessarily reflect the way that your Brinkley RV is equipped. By way of example, the termination valve handles shown in the pictures do not exist on your Brinkley RV as we provide electric termination valves.

**+ NOTICE**

To help ensure debris does not clog tank sprayer orifices, use **“TANK FLUSH”** every time waste holding tank is emptied.



## SEC.21 PLUMBING SYSTEMS

### 8. Integrated Fresh Water Retractable Hose Reel

Your RV is equipped with an integrated fresh water retractable hose reel. The hose reel is mounted behind the convenience center and is located on a drainage pan that permits any water to run out through the bottom of the RV. Each end of the hose reel protrudes out of the front of the convenience center panel as shown below. The total length of the hose is 65 feet (19.8 m). You should have 55-60 feet (16.7-18.3) of available hose to utilize. The hose end on the left in the convenience center is the end that can be extended and retracted. Simply pull on the hose to extend. To retract, lightly tug on the hose and keep any tension off of the hose as it retracts.

The hose end on the right in the convenience center is used to connect to either the **CITY FILL** or the **TANK FLUSH** connections.



### N. DRAINING THE FRESH WATER SYSTEM

Before storing the RV throughout winter months, the water system should be drained and winterized. This should be completed for all components of the water system including the hot and cold-water lines, water heater, faucets, and P-traps. Under your RV, you will notice red and blue water lines with shut OFF valves. These release the water within the supply lines and are referred to as the low point drains. To drain all water from the supply lines and fresh tank, follow the instructions (top right).

### DRAINING THE FRESH WATER SYSTEM:

1. **OPEN** all faucets, including the outside shower (If Equipped) and external spray down ports.
2. **OPEN** the Fresh Water Holding Gate Valve. This valve is a white T-handle valve that is located under the RV and close to the axle. See photo below.



3. **OPEN** both low point drain. See photo below.



4. **DRAIN** all sinks.
5. Turn **ON** the water pump to ensure all water is purged from the RV.
6. **After draining the Fresh Water System, REVERSE these steps to ensure the system is closed back up.** It is common for a small amount of water to remain in the system.

## O. SANITIZING THE FRESH WATER SYSTEM

The Fresh Water System should be sanitized after purchase of the RV, anytime contamination may have occurred, and after extended periods of no use. Please follow the below instructions to sanitize the Fresh Water System.

- Mix one (1) gallon water (3.78 liters) with a ¼ cup (59.14 ml) of household bleach (5% sodium hypochlorite solution).
- You will need approximately one (1) gallon (3.78 liters) of solution for every fifteen (15) gallons (56.78 liters) of tank capacity.

### + NOTICE

If you choose to buy an aftermarket solution, please refer to the supplied instructions and follow as directed.

### SANITIZING THE FRESHWATER TANK AND SYSTEM:

1. **ENSURE** the RV is level.
2. **EMPTY** the fresh tank by opening the fresh water holding gate valve.
3. **CLOSE** the fresh water holding gate valve. See picture below.

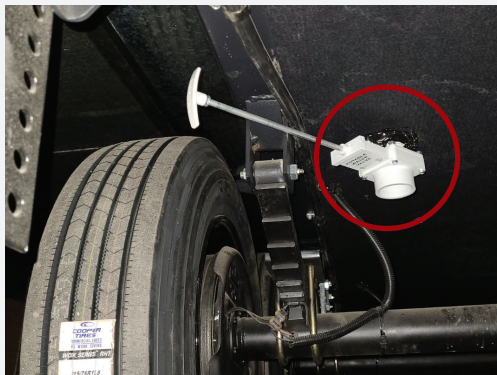

4. **ENSURE** the low point drains are closed. See picture, top right.

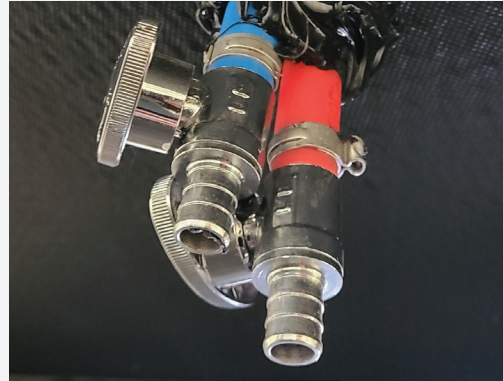

5. **CONNECT** a garden hose to the City Water port and the other end into the sanitizing solution. **DO NOT** use your portable freshwater hose. See picture below.



6. Turn **ON** the water pump and run it until the solution is empty.
7. **PROCEED** by filling the freshwater holding tank.
8. **PURGE** all waterlines by turning on the faucets. You must purge both the hot and cold lines of each faucet. Once completed, turn **OFF** the water pump.
9. **ALLOW** the sanitization solution to stand for at least three (3) hours.
10. **DRAIN** and **FLUSH** the Fresh Water System with fresh water.
11. To remove excess chlorine odor, mix one (1) quart (.94 liters) vinegar to five (5) gallons (18.9 liters) water and repeat steps 3-9 above.



## SEC.21 PLUMBING SYSTEMS

### P. WINTERIZING THE PLUMBING SYSTEM

Preparing for storage is vital step for the protection of your RV. Anytime temperatures are likely to drop near or below 32° F (0° C), the RV should be winterized. This is to prevent the waterlines, tanks, and the water heater from freezing and becoming damaged. The plumbing system should only be winterized with RV antifreeze and no other solutions.

#### + NOTICE

Always clean RV antifreeze from all surfaces to prevent staining in the sinks, tub, or toilet.

#### ⚠ WARNING

**NEVER use automotive antifreeze or windshield washer anti-freeze as they are poisonous. They are harmful when consumed and may be fatal if swallowed.**

#### + NOTICE

Winterizing the RV may be more efficient and easier if another person is able to assist you. Please contact your Dealer for assistance if needed.

#### BEFORE YOU START:

Here are the items that you will need:

1. 3 gallons (11.35 liters) of non-toxic RV/Marine antifreeze (Customer Supplied).
2. Air compressor with pressure regulator capable of producing 30-40 psi (206.8-275.8 kPa) of pressure.
3. Standard Air Compressor Quick Connect Fitting. Picture shown above right (Customer Supplied).

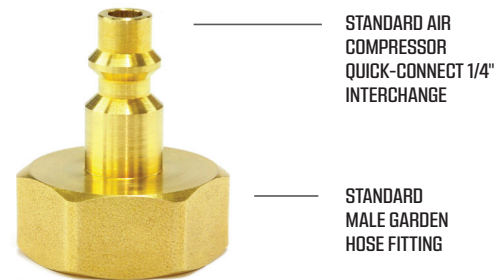

4. A short length of garden hose that has a male fitting on one end.
5. A full-length garden hose or the supplied retractable hose reel to flush the black and gray tanks.

#### + NOTICE

The black and gray tanks should already be emptied of wastewater before commencing the winterization process.

#### FOLLOW THESE STEPS TO WINTERIZE:

1. **LEVEL** the RV. See [Section 8](#).
2. **CONNECT** the provided hose from the retractable hose reel (See [Section 21L\(8\)](#)) or a full-length garden hose to the tank flush inlet and to a water supply source (i.e., an outside water spicket). See picture below for the hose attachment location.



3. **FLUSH** the black holding tank(s) utilizing the tank flush line. See [Section 21L\(7\)](#) for instructions on how to flush the black tank(s).

4. **DRAIN** all black, gray, and freshwater holding tanks.

- a. See [Section 21S\(3\)](#) for instructions on how to empty the black and gray holding tanks.
- b. See [Section 21M](#) for instructions on how to drain the freshwater tank(s).

5. **CLOSE** the black, gray, and freshwater valves after they have all drained.

6. **SET** the convenience center panel to **POWERFILL** by setting the valves on the convenience center as indicated in the picture below. The blue and white valves should be pointed downward. The green valve should point left.



7. Turn **OFF** the water heater (See [Section 21I](#)) from the water heater controller in the bathroom cabinet. Use compressed air to blow out the remaining water in the water heater. This can be performed by opening the low point drains, all hot handles on the faucets, and connecting air to the water inlet. Make sure you do not exceed 30 psi (206.8 kPa) when blowing compressed air into the waterlines. The picture above right shows the location of the water heater on the exterior of the unit on the off door side.

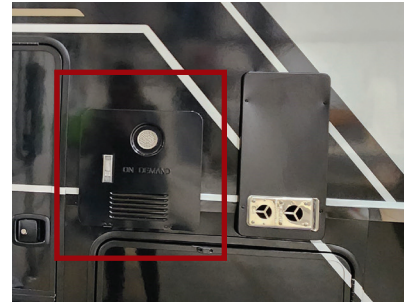

8. Turn **OFF** the water pump. You can turn the water pump off at the Convenience Center (picture below left) or the OneControl Touch Panel (picture below right).



OR



9. **OPEN** the low point drains. They are located underneath the RV on the off door side of the RV and protrude through the underbelly. Allow all water to drain.



10. **FLUSH** the toilet to remove all water from the toilet bowl. You will need to keep the toilet flush foot pedal depressed on the toilet until all water is drained from the toilet.

## SEC.21 PLUMBING SYSTEMS

11. **OPEN** all interior faucets and turn **ON** the interior shower(s). You should complete these steps at each faucet one at a time. At each location:
  - a. Start by opening the hot water valve. Leave the valve open until all water is drained. Then close the hot water valve.
  - b. Then, open the cold-water valve. Leave the valve open until all water is drained. Then close the cold-water valve.
  - c. **NOTE:** If the faucet does not have separate hot and cold-water valves, you must first open the valve with the handle set all the way to hot. Then move the handle all the way to cold.
12. **CONNECT** using the supplied quick connect hose (see picture in 'c' below) to the exterior faucets (one at a time).
  - a. Start by opening the hot water valve. Leave the valve open until all water is drained. Then close the hot water valve.
  - b. Then, open the cold-water valve. Leave the valve open until all water is drained. Then close the cold-water valve.
  - c. Repeat at the other exterior faucet location. The two locations are shown in the photos immediately below:



13. **SET** the Convenience Center Panel valves as indicated in the picture at the top right:



14. Using the **CITY WATER INLET** (located at the red circle shown in the picture above) on the convenience center panel:
  - a. **ATTACH** the air compressor quick connect fitting to the city water inlet;
  - b. **ATTACH** the air compressor hose to the quick connect fitting;
  - c. **SET** the air compressor regulator to 30-40 psi (206.8-275.8 kPa).
  - d. **TURN** the air compressor on.
15. **CLOSE** the low point drains after allowing all water to drain.
16. **REPLACE** the drain plug in the water heater after allowing all water to drain.
17. **REPEAT** steps 10, 11 and 12 above while the air compressor is still attached and on.
18. **TURN OFF** the air compressor and disconnect the air hose and fitting from the **CITY WATER** inlet on the convenience center.

19. **SET** the valve handles on the convenience center panel to **WINTERIZE** as shown in the photo below:



20. **CONNECT** a short section of garden hose to the inlet labeled “**CITY WATER**” on the convenience center panel and as shown in the picture immediately above.
21. **PLACE** the other end of the garden hose into the RV antifreeze jug.
22. **TURN ON** the water pump. See step 8 for the water pump switch locations.
23. The pump should be running, and the RV antifreeze should begin to flow through the pump into the plumbing lines and fixtures.
24. **REPEAT** steps 10, 11 and 12 until antifreeze is present at each location. You should permit RV antifreeze to flow from each fixture. You must perform this at each location one at a time.
25. **TURN OFF** the water pump once antifreeze is present at all fixtures.
26. **DISCONNECT** the garden hose from the convenience center panel.

27. **POUR** RV 1/2 cup (118.3 ml) of RV antifreeze down each sink drain and 1 cup (236.6 ml) of RV antifreeze down toilet drain.

28. **COMPLETE!** Your plumbing system is now prepped for winter storage.

## Q. DE-WINTERIZING THE PLUMBING SYSTEM

### BEFORE YOU START:

You will need the following items before you start the winterization process:

1. A 5-gallon (18.9 liters) bucket.
2. Household bleach.
3. 8-12 ounces (236.6-354.8 ml) of fresh water in a small bottle.
4. A liquid measuring cup.
5. A garden hose (or utilize the supplied hose of the retractable hose reel (See [Section 21L\(8\)](#)).

The Fresh Water System should be sanitized after purchase of the RV, anytime contamination may have occurred, and after winterization or extended periods of no use. Please follow the below instructions to sanitize the freshwater system:

- Mix one (1) gallon (3.78 liters) water with a ¼ cup (59.14 ml) of household bleach (5% sodium hypochlorite solution).
- You will need approximately one (1) gallon (3.78 liters) of solution for every fifteen (15) gallons (56.78 liters) of freshwater holding tank capacity. You should place this mixture in the 5-gallon (18.9 liters) bucket.

Please consult your Dealer if you have questions regarding the size of your fresh water holding tank or contact Brinkley RV Customer Care.



# SEC.21 PLUMBING SYSTEMS

To De-Winterize, follow the following steps:

1. Ensure the RV is level (See [Section 8](#)).
2. **ENSURE** the low point drain is closed. They are located underneath the RV on the off door side of the RV and protrude through the underbelly. See the picture above right for an example of the low point drains.



3. **CONNECT** the provided hose of the integrated hose reel or a garden hose to the **CITY WATER** port on the convenience center. See picture, right. Place the other end of the garden hose in the 5-gallon (18.9 liters) bucket that contains your sanitizing solution.
4. **SET** the convenience center valves to **SIPHON** (white valve pointing right, blue valve pointing down, green valve pointing left). See picture, below.



5. **TURN ON** the water pump and fill the fresh tank with the full amount of sanitizing solution. You can turn the water pump on at the Convenience Center (picture below left) or the OneControl Panel (picture below right):



OR



6. **FLUSH** the toilet and keep the foot pedal depressed on the toilet until all the RV antifreeze is purged from the toilet and the sanitizing solution is flowing into the toilet bowl.
7. **ADD** 8-12 ounces (236.6-354.8 ml) of fresh water into the toilet bowl to dilute the sanitizing solution at the toilet seal.
8. **OPEN** all interior faucets and turn **ON** the interior shower(s). You should complete these steps at each faucet one at a time. At each location:
  - a. Start by opening the hot water valve. Leave the valve open until all the RV antifreeze is purged and the sanitizing solution is present and flowing from the faucet. Then close the hot water valve.
  - b. Then, open the cold-water valve. Leave the valve open until all the RV antifreeze is purged and the sanitizing solution is present and flowing from the faucet. Then close the cold-water valve.

## + NOTICE

If the faucet does not have separate hot and cold-water valves, you must first open the valve with the handle set all the way to hot. Then move the handle all the way to cold.



9. **CONNECT** using the supplied quick connect hose to the exterior faucets (one at a time).
  - a. Start by opening the hot water valve. Leave the valve open until all the RV antifreeze is purged and the sanitizing solution is present and flowing from the faucet. Then close the hot water valve.
  - b. Then, open the cold-water valve. Leave the valve open until all the RV antifreeze is purged and the sanitizing solution is present and flowing from the faucet. Then close the cold-water valve.
  - c. Repeat at the other exterior faucet location. The two locations are shown in the photos immediately below:



10. **ALLOW** the sanitation solution to stand in the water lines for at least three (3) hours.
11. **DRAIN** all black, gray, and freshwater holding tanks.
  - a. See [Section 21T\(3\)](#) for instructions on how to empty the black and gray holding tanks.
  - b. See [Section 21N](#) for instructions on how to drain the freshwater tank(s).
12. **FILL** the freshwater holding tank with fresh water only. Repeat step 7 through 11 above to purge the system of the sanitizing solution. Note that each fixture should be run for approximately 20 seconds each to flush the lines of the sanitizing solution.

13. **REPEAT** step 12 in its entirety a second time to ensure the sanitizing solution is completely removed from the plumbing system.

14. **COMPLETE!** You are now ready to go RV'ing!

## R. BLACK WATER AND GRAY WATER SYSTEMS

The toilet in the RV drains to the black water holding tank. The shower and sinks within the RV drain to the gray water holding tank.

- Before towing the RV, the gray and black holding tanks should be emptied to avoid carrying unnecessary weight.
- If you are unable to empty the tanks while dry camping, reduce your towing speed until these tanks can be emptied at the next dump station.

### + NOTICE

The cargo carrying capacity of the RV is based on ALL holding tanks being empty. If the tanks are full, this weight must be deducted from the cargo carrying capacity unless in Canada.

### ⚠ WARNING

Traveling with full holding tank(s) may result in:

- Limiting available cargo carrying capacity
- Exceeding the GAWR or GVWR
- Damage to suspension components i.e., as springs, tires, and axles)
- Fluctuating hitch weight, depending on the location of the holding tanks and which tanks are filled
- Unwanted towing characteristics such as trailer sway and other handling difficulty.

# SEC.21 PLUMBING SYSTEMS

## S. TOILET

### 1. General

The toilet in the RV uses roughly three (3) quarts (2.84 liters) of water per flush. This amount is about ten times less than that of a residential toilet. When flushing solids, additional water may be needed to fully remove waste from the lines.

#### + NOTICE

When flushing, **ALWAYS** continue to run water for an extra 10-15 seconds after flushing. If enough water is not used, pipes and tanks may become clogged.

#### ⚠ WARNING

**NEVER use automotive antifreeze, windshield washer anti-freeze, laundry detergents, or other caustic chemicals as they are poisonous. Although these products may have deodorizing capabilities, they are damaging to the components within the plumbing system and are toxic if ingested.**

### 2. Preventing Toilet Blockage

- Before using the toilet, ensure there is sufficient water in the toilet, approximately 4-6 inches (10.16-15.24 cm). This can be accomplished by flushing the toilet several times until water is present.
- Use RV grade, single-ply toilet paper.
- Never flush baby wipes, disposable wipes, or any other foreign objects down the RV toilet (i.e., hygiene products, feminine products, cleaning wipes, paper towels, diapers).

### 3. Cleaning and Maintenance

- Clean the toilet on a regular basis.
- Use tank treatments to clean the black tank when needed.

- Applying petroleum jelly when needed to the toilet ball valve to provide waterproof lubrication without damaging other seals.

#### + NOTICE

Never use chlorine or other abrasive solutions in the RV toilet (i.e., laundry bleach, chemical drain openers). These products will **DAMAGE** the seals in the toilet and dump valves.

#### + NOTICE

It is vital to prevent solid buildup in the drain lines and black tank. Follow the toilet manufacturer's manual for instructions and maintenance information.

## T. BLACK AND GRAY WATER HOLDING TANKS

### 1. Black Water Tank Preparation

To help break down solid contents within the tank and to minimize odors, a deodorizer treatment (Customer Supplied) should be used. Please see the following instructions.

#### **AFTER DUMPING THE HOLDING TANKS, AND BEFORE THE FIRST USE:**

1. **RELEASE** roughly one to two quarts (1-2 liters) of water into the toilet bowl.
2. **ADD** the suggested amount of tank deodorizer (Customer Supplied) by inserting the content into the toilet.
3. **FLUSH** the toilet and allow an additional two (2) gallons (7.57 liters) of water flow into the holding tank.

## 2. Gray Water Tank Preparation

No preparation is needed for the gray tanks. To help control odors, add a small amount of baking soda or RV tank deodorizer down the drains as needed.

## 3. Emptying Black and Gray Water Tanks

At the top of the convenient center, you will find the black and gray tank drain valve switches, also referred to as dump valve switches. When dumping the black and gray tanks, it is important to dump the black holding tank first, then the gray tank. This will help to remove any solids left behind from dumping the black tank.

### EMPTYING BLACK AND GRAY TANKS:

1. Generally, accumulated solid waste will loosen within the black holding tanks as the RV is transported to a disposal location.
2. Always level the RV before dumping to make the process more efficient. See [Section 8](#).
3. **LOCATE** the Sewer Outlet on the off door side. See picture, bottom right. See [Section 21T\(4\)](#).
  - a. **REMOVE** the housing cap on the outlet.
  - b. **ATTACH** a sewer hose to the outlet (Customer Supplied).
4. **PLACE** the opposing end of the sewer hose in the designated dump location.
5. **OPEN** the Black Tank Dump Valve by pressing the black dump switch to the **OPEN** position. The indication light will then turn on signifying the dump valve is open.

6. **CLOSE** the tank valve by pressing the dump valve switch to the **CLOSED** position. The indication light on the black dump valve switch will turn off signifying the dump valve is closed.
7. **EMPTY** the gray tanks by pressing the gray dump valve switch to the **OPEN** position. The indication light will then turn on signifying the dump valve is open.
8. **REMOVE** the sewer hose once all tanks are emptied, clean them, and store for the next use.
9. **ENSURE** the cap on the sewer outlet is reinstalled.

### When Connected at the Campsite Sewer Drain:

Keep the dump valve switches closed until the tanks are  $\frac{3}{4}$  full to prevent solids from building in the drain lines. Never keep the black dump valve switch open.

### 4. Gray and Black Tank Valve Switches, Sewer Outlet, and Sewer Hose Storage Tube

The picture below shows the black and gray tank valve switches. They are located at the top of the convenience center panel.



## SEC.21 PLUMBING SYSTEMS

The picture below shows the sewer outlet on the off door (driver) side of the RV. The sewer outlet cap on your RV is clear so that you can make sure there is not wastewater behind the cap prior to taking the cap off.



The picture below shows the sewer hose storage tube. The tube is capable of storing two sections of hose. The valve ends of the hose have to be removed prior to storage.



### 5. Manually overriding the Gray and Black Power Tank Valves

In the event that you lose power to your RV or the electric tank valves are not functioning, you can utilize the manual override to open and close the tank valves.

You have three override valves within your RV. Two are located centered behind the front pass-through storage just under the underbelly of the RV, and the other is located towards the off door (driver) side of the RV just behind the rear axle, under the underbelly.

For general location of the tank valves, please see the photo shown top right.



### TO MANUALLY OVERRIDE THE FRONT TANK VALVES:

1. Locate and open the compartment door on the off door (driver) side right of the pass-through compartment.

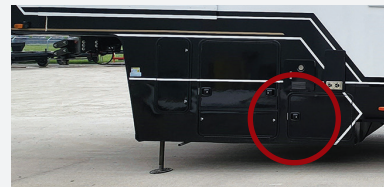

2. Fully extend the MORryde cargo tray so that it is out of the way.
3. Once the cargo tray is extended, drop the lower underbelly by removing the securement screws along the perimeter of the underbelly. This will reveal an access door into the upper underbelly.
4. Open the underbelly access door to reveal the tanks and the plumbing components.
5. Locate the U-shaped bracket shown below and carefully pull the bracket and rod outward to open the valve. Push the bracket inward to close the valve.



6. Reverse steps 1 through 4 to reassemble your RV once the valve is back into its closed position.



**TO MANUALLY OVERRIDE THE REAR TANK VALVES:**

1. Locate and open the underbelly access door found just behind the rear axle. This will reveal the rear tank and its plumbing components.
2. Locate the term valve and the U-shaped bracket at the end of the term valve motor.
3. Carefully pull the U-bracket and rod outward to open the valve. Push the bracket inward to close the valve.

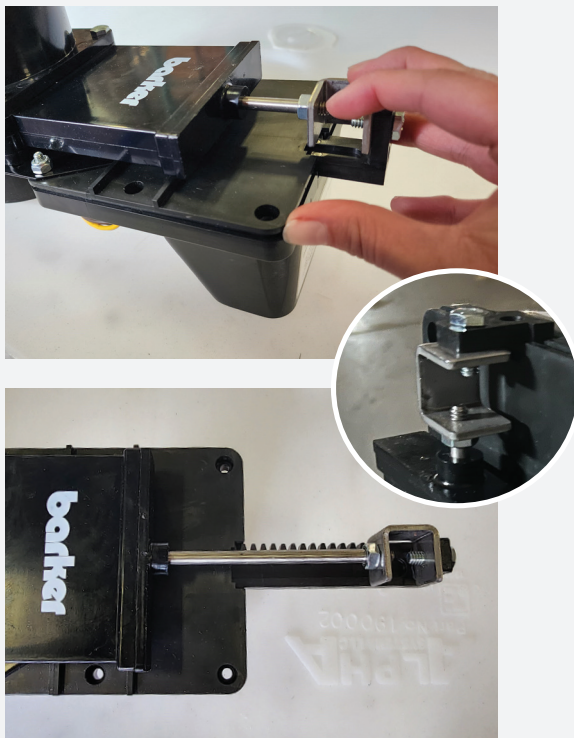

4. Reverse steps 1 through 4 to reassemble your RV once the valve is back into its closed position.

For further assistance, please contact your Dealer or Brinkley RV Customer Care.

**6. Dump Station Locations**

Dump station location can be found on many websites, campground ground offices, and publications including Good Sam Camp Guide, KOA campgrounds Camp Guide, Woodall's Campground Magazine, Rand McNally Camp Guide, etc. Dump stations can also sometimes be found at local gas stations.

The sewer hose and its components are the Customer's responsibility to purchase. If you need assistance, please contact your Dealer or Brinkley RV Customer Care.

**7. Vents and Vent Pipes**

It is vital to keep all exterior plumbing vents clear and free of any possible obstructions. If these vents become clogged or obstructed, the tanks will not be able to properly drain. Inspect these vents on a frequent basis and clean as needed.

**8. Drainpipes With Dry Sealing Valve**

A waterless P-trap is used on the drain system of the RV. This form of P-trap will help to prevent odors from escaping the waste system and eliminates the need of a traditional P-trap. In the circumstance the drain becomes clogged with this installation, a mechanical clean-out tool will need to be used to clear the obstruction.

**+ NOTICE**

The dry waterless P-trap **MUST** be removed before using a mechanical clean-out tool. If the dry valve is not removed, the seal will become damaged and will not operate as designed. This will become evident as you will begin to smell odors from the drainage.



# SEC.21 PLUMBING SYSTEMS

## 9. Black Tank Flusher

Your RV is equipped with a black tank flusher. This feature is designed to rinse the interior portion of the black tank through a separate water connection port. To prevent water from backflowing, there is a check valve installed in-line. See [Section 21M\(7\)](#), Rinsing the Waste Tank—“Tank Flush.”



### FLUSHING THE TANK AFTER DUMPING:

1. After draining the tanks, leave the sewer hose connected to the drain outlet and the dump location.
2. Connect the external water source to the black tank flusher inlet.



3. Open the black tank valve.
4. Turn on the water source to flush the tank.
5. When the drainage begins to run clear from the sewer hose, turn off the water source and disconnect it from the RV.
6. Disconnect the sewer hose **AFTER** all water is drained from the system.

### ⚠ WARNING

When the tank is being flushed, the black tank gate valve must be open. Failure to open the valve will result in damage to the system and may lead to unsanitary conditions that may further result in illness or personal injury.

### + NOTICE

DO NOT add any check valves to this system or leave any hose connected when not in use.

**A. ENTERTAINMENT RECLINER SOFA**

The sofa found within the main living quarters of the RV is an entertainment recliner sofa. Each section of the sofa is capable of being reclined via the pull handles displayed in the below photo.



To engage the recline position, simply pull the handle in an upward position until you feel the foot rest release.

At each end of the sofa, you will notice a round control recessed in the arms of the sofa. This control contains a USB-A charge port along with controls for the heat and massage features of the sofa. To turn the heat feature on, press the button with the red heat waves. When the button is illuminated, the heat feature is on. Depending on the temperature of the RV, it may take a couple minutes for the seat to warm.

To operate the massaging feature, press the button with the blue massage icon. The button will illuminate when the massage feature is activated. Upon engaging the massager, you will immediately feel the vibration in the back rest of the sofa.



**B. ENTERTAINMENT STANDS**

On either side of the recliner sofa, there are two entertainment stands. When looking at the surface of the table, you will notice that the top is divided into two sections roughly 3/4 of the way back. The front portion of the entertainment table top covers a hidden storage compartment, and the rear portion provides access to a hidden power supply.

**Hidden Storage**

To gain access to the hidden storage compartment, gently pull up on the front edge of the storage lid. This is demonstrated in the photos below.





## SEC.22 FURNITURE

### Hidden Power Supply

On the rear portion of the entertainment stand, there is a hidden compartment housing a 120-volt outlet, USB-C, and USB-A power supply. To gain access to this power supply, firmly press down on the front portion of the rear section of the top. When you hear a click, release the pressure. The rear portion will then open and provide access to its power supply. Please see the photos below.



PRESS FIRMLY DOWN UNTIL A CLICK IS HEARD



2 120-V OUTLETS, 1 USB-C, 1 USB-A

### G. DINETTE TABLE (IF EQUIPPED)

The dinette table is stored on the Happijac bunk in the rear garage area of the RV.



The dinette table is a folding table capable of seating four to six people comfortably and can be utilized outdoors, on the patio, or in the garage area. It can be used as a table, or a desk. Once the table is removed from the bunk location, you will need to fold out the legs and lock them into place prior to use. See the below photo.



To store, return the legs into the storing position, place the table on the bunk, and secure it into place with the supplied securement strap. The table must be secured prior to travel to prevent damage occurring to the RV.

### D. BEDROOM DRESSER

The dresser located in the main bedroom also has hidden storage located underneath the dresser top. To access the storage, simply pull the dresser top forward, as it is attached to a set of drawer glides. The picture below shows the dresser top in the closed position.





The picture below shows the dresser top in the open position providing access to the upper storage area of the dresser.



## E. HAPPIJAC SOFA

Under the Happijac bunk in the garage there are two Happijac sofas. These particular sofas can be used either as sofas or as an additional bunk bed. Below is a photo showing the sofa in the “sofa mode.”



To place the sofa into its bunk bed configuration,, the following instructions will need to be followed.

### HAPPIJAC SOFA TO BED:

1. Pull the top of the back rest towards the center of the garage.
2. Pivot the back rest of the sofa forward and then fully rotate the back rest until it is in the bunk position.



3. Locate the support legs under the sofa backrest. Rotate the legs 90 degrees and extend them until they make contact with the garage floor. Prior to applying weight to the bed, make sure the detention lock circled in red is fully engaged. For additional information on the Happijac system, please See [Section 10](#).



## SEC.23 ENTRY DOOR & STEP SYSTEM

Your RV has three primary entry points: the main entry door in the main living area, the secondary entry door in the garage area, and the 3-Seasons door in between the garage and patio. Each door contains its own unique purpose and features which are outlined and explained below.

### A. MAIN ENTRY DOOR

#### 1. Integrated Window Shade

The picture below has a red rectangle around the entry door window. This is the location of the pleated integrated window shade. To operate, you must be outside the unit and separate the screen door from the main entry door. This will give you access to the shade. Simply pull up or down on the shade to extend or retract the shade.

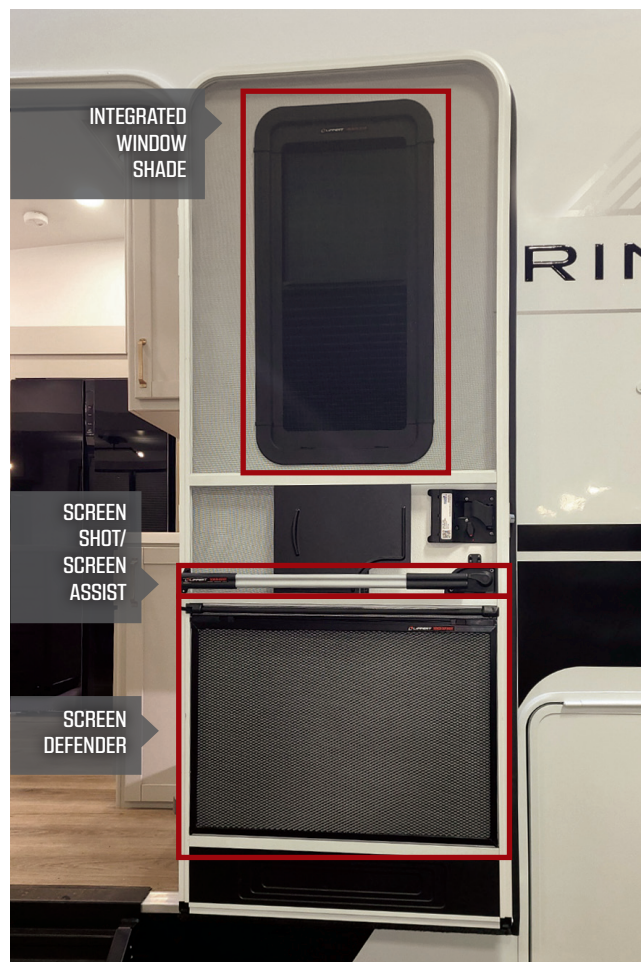

#### 2. Lippert Screen Shot

The middle red rectangle highlights two features of the entry door. The first is the Lippert Screen Shot. This is the black tube that runs parallel to the ground below the door latch. It has a spring-loaded strap that automatically shuts the screen door after it has been opened.

#### 3. Lippert Screen Assist

The second feature indicated by the middle red rectangle in the picture to the right is the Lippert Screen Assist. This item is connected to the screen door latch and allows you to press down on the Lippert Screen Assist to open the screen door.

#### 4. Lippert Screen Defender

The last feature on the interior of the entry door is the Lippert Screen Defender. This item is a removable screen that protects the lower portion from the screen door against pets and small children damaging the screen or pushing through the screen to the exterior of the unit.

#### 5. Keyless Entry

Your entry door comes equipped with a 5-touch button, programmable deadbolt lock, that utilizes a 4-digit code. This will allow keyless entry into the RV. It is activated by touch and does not require depressing the button. Four of the buttons are labeled "1/2", "3/4", "5/6", and "7/8". The fifth button is the command/enter key that tells the lock to lock or unlock after the pass code is entered.





### USING THE ENTRY DOOR KEYPAD:

1. Touch any number to “Wake Up” the lock.
2. You will notice the buttons light up when the lock is “awake”.
3. The default code is 3, 7, 1, 5, followed by the enter button. The enter button is below the “7/8” button shown with the key on it (see picture on previous page).
4. Touch and hold the “3/4” button, and the enter button simultaneously for 2 seconds. You will hear 3 beeps. The lock is now ready to accept a new code. Now enter a 4-digit code followed by the enter button. The lock will beep 4 times indicating that your new code has been accepted.

### + NOTICE

Losing battery power will not reset the code. Once a new code is programmed, the programmed code will be the code used in step 3 when reprogramming.

For bluetooth connectivity, visit <https://www.brinkleyrv.com/owners-hub/>. For further information, please refer to the manufacturer’s manual.

### + NOTICE

The keyless touch pad only locks and unlocks the entry door deadbolt. The paddle or handle lock is keyed. If you intend to lock the RV without taking your keys, make sure the paddle lock is unlocked and only the deadbolt is locked.

### ⚠ CAUTION

**Do not powerwash the keyless entry door lock or use abrasive cleaners on the lock and keypad. Doing so can permanently damage the lock and keyless entry feature.**

## 6. Telescoping Handrail

Your RV is equipped with a telescoping handrail to facilitate safe ingress and egress into and out of the RV. The picture below shows the location of the handrail. It is held in place for transit utilizing a magnet and travel pin

### DEPLOYING THE HANDRAIL:

1. Remove the travel pin and grab the handrail at the bottom. Pull outward as shown in the picture below.



2. There is an inner and outer channel that comprises the handrail. Once the handrail is extended in step (1), firmly grab the inner channel located at the bottom of the handrail and pull it down and outward until the inner channel is fully extended. When complete, your handrail should look like the photo below.



3. Reverse steps (2) and (1) above to stow the handrail for travel. Be sure to fully seat the handrail so that the magnet engages to the side wall of the RV and insert the travel pin.

# SEC.23 ENTRY DOOR & STEP SYSTEM

## 7. Main Entry Door Step System

Your main entry door step stows inside of the entry door.

### DEPLOYING THE MAIN STEPS:

1. Open the entry door fully.



2. While holding on to the step, pull the blue lever to release the step from the door jamb. See the picture below displaying the blue handled latch.



### ⚠ WARNING

It is important that you have a good grasp on the step as you are lowering the step system. A failure to hold on to the step firmly could result in the step system dropping suddenly and hitting you on the head, neck, shoulder, or face resulting in injury.

3. Slowly walk backwards and allow the step to lower to the ground. The step should look like the photo below.



4. Grab the top of one of the step treads and pull towards you until the steps are fully seated in the down position. The steps should look like as shown in the picture below.



5. Adjust the extension legs of the step on both sides by pulling the provided pins and adjusting the leg lengths so that the step treads are parallel to the ground. Please see the picture below for the location of the adjustment pins.



6. Reverse the steps to stow your step system for travel. Note that the steps can be cleaned and allow any water to run off prior to stowing the step by flipping the treads into the up position. Clean as needed.

**⚠ WARNING**

When putting the step away for travel, it is important that you ensure the blue latching mechanism is properly latched to the entry door jamb. Failing to do so could result in the step system detaching from the door jamb in transit resulting in damage to the step, entry door, and potentially other interior components of the RV.

**⚠ WARNING**

Make sure you hold onto the steps the entire time while lowering and lifting them into position. If you feel you are unable to handle the weight of the stairs, ask for help prior to attempting to operate on your own. Failure to do so may result in personal injury or harm.



## SEC.23 ENTRY DOOR & STEP SYSTEM

### B. GARAGE ENTRY DOOR

The garage entry door contains many similar features as the main living entry door but does vary slightly. The features are outlined below.



#### 1. Lippert Screen Shot

Found at the center of the screen door, you will find two features of the entry door. The first is the Lippert Screen Shot. This is the black tube that runs parallel to the ground below the door latch. It has a spring-loaded strap that automatically shuts the screen door after it has been opened.

#### 2. Lippert Screen Assist

The second feature you will find at the center of the screen door is the Lippert Screen Assist. This item is connected to the screen door latch and allows you to press down on the Lippert Screen Assist to open the screen door.

#### 3. Lippert Screen Defender

The last feature on the interior of the entry door is the Lippert Screen Defender. This item is a removable screen that protects the lower portion from the screen door against pets and small children damaging the screen or pushing through the screen to the exterior of the unit.

#### 4. Keyed Lock

Your garage entry door comes equipped with a keyed deadbolt lock. The keys will be supplied with your RV at the time of purchase. A picture of the lock can be found below.



### 5. Grab Handle

The garage entry door comes equipped with a grab handle. This grab handle is directly attached to the sidewall of the RV and looks like the below picture.



### 6. Garage Entry Door Steps

The garage door is equipped with folding steps that store directly under the entry door itself. The step location is shown in the picture below.



To safely deploy the garage stairs, follow the provided instructions.

### DEPLOYING THE GARAGE STEPS:

1. Grab the center handle shown in the below photo and pull forward as you rotate in a downward motion.
2. Stepping backward carefully to allow the step to fold forward and out toward the ground.
3. Grab the support bar on the backside of the second to last step. Pull the handle up, rotate forward, and down to get the step into position. This will expose the last step.
4. Repeat step 3 to deploy the last step.
5. Repeat steps 1 through 4 in reverse to properly close the garage steps.





# SEC.23 ENTRY DOOR & STEP SYSTEM

## C. 3-SEASONS DOOR

Your RV comes equipped with the Lippert 3-Seasons Door. This door includes a four panel assembly, screens, blackout shades, and a lock assembly. This door assembly can be operated as both a sliding door or as two pivot doors. This door separates the garage area from the patio and rear exterior of the RV.

### + NOTICE

To fully operate the 3-Seasons door, the ramp door must be opened and the patio rails will either need to be in rail position or opened for loading.

#### 1. Interior Lock

From the inside of the unit, a lock assembly is visible on the 3-Seasons door. It looks like the below photo.



This lock provides some security and also acts as a securement for the door assembly when transporting the RV.

### ⚠ CAUTION

**This lock must be properly engaged prior traveling with the RV. Failure to do so may result in serious damage to the RV.**

#### OPERATING THE LOCK:

1. Lift the lock from the latch.

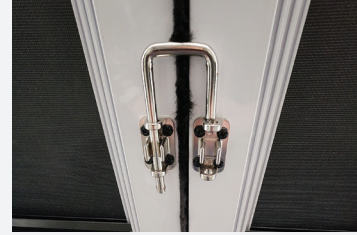

2. Rotate the lock and allow it to fall.

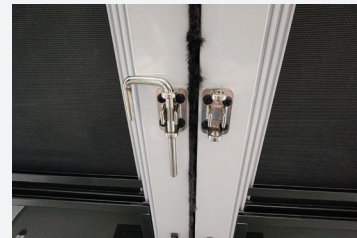

3. To lock the doors, ensure the doors are fully closed and repeat steps one and two in reverse order.

#### 2. Exterior Handles

The 3-Seasons door comes equipped with two grab handles. These are located on the both outside and inside of the RV on the inner two panels of the 3-Seasons door. These handles will allow you to open and close the 3-Seasons door.



#### 3. LED Lighting

The 3-Seasons door comes equipped with accent LED lighting. This lighting is located around the perimeter of the 3-Seasons door. These lights will turn on as the garage lights are operated.

#### 4. Screens

Each panel of the 3 seasons door is equipped with screens to provide fresh air into the RV while deterring insects.

## 5. Sliding Panels

The inner two panels of the 3-Seasons door are installed on a recessed track that allows the doors to slide open and closed. Prior to operating, the door must be unlatched and the ramp door should be opened.

### OPERATING THE SLIDING PANELS:

1. Unlatch the 3-Season door.

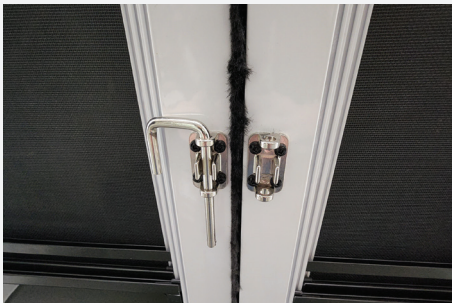

2. Grab the handles and slide the doors open along the track.
3. As the panel meets the outer panel, stop sliding. Use care when opening and closing the doors to prevent the doors from jumping out of their tracks.
4. Repeat step two and three to open the other inner panel.



5. To close the inner panels repeat all steps in reverse.

## 6. Pivot Panels

Once the inner two panels are fully open, the outer two panels are capable of pivoting open. This is to allow for a greater opening when loading the garage area. The instructions to operate this function are outlined below.

### PIVOTING THE OUTER PANELS:

1. Make sure the inner panels are fully slid open.
2. Locate and grab the release cable found on the inside of the outer panel. For location, please see the photo to the right. The pull cable is circled in red.
3. Pull the cable towards you.



4. As you feel the latch release, carefully begin to pivot the door outward.
5. Repeat steps three and four to open the opposing outer panel.



## SEC.23 ENTRY DOOR & STEP SYSTEM

### CLOSING THE PIVOTING PANELS:

1. Pivot the outer panel back into its closed position.
2. Ensure you hear the latch re-engage.
3. Repeat steps one and two for the opposing panel.
4. Slide the inner panels closed.
5. Latch the lock assembly.

### 7. Removable Panels

The panels of the 3-Seasons door can also be fully removed. This feature has been added to provide additional clearance if larger desired items are to be loaded. Instructions to fully remove these panels can be found below.

### REMOVING THE DOOR PANELS

1. Locate the label that says, “Removable Door Feature.” This can be found on the inside of the inner panel on the side closest to the wall. A photo of the label is shown below.



2. Just above this label, you will find a silver plate on the door bracket with two screws. Using a phillips bit, remove the two screws, fully exposing the opening on the upper bracket



3. Pivot the inner panel so it aligns with the circled groove on the upper bracket shown in the below photo.

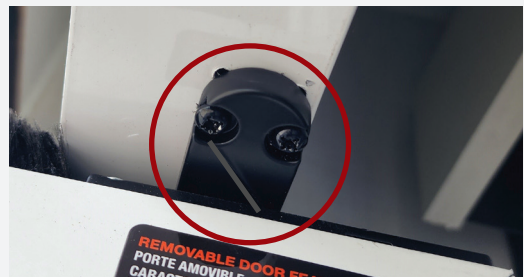

4. Once aligned, carefully tilt the panel back towards the RV. As the panel is released from the upper bracket, the full weight of the panel set will be in your hands. If assistance is needed, be sure to ask for assistance before releasing the panel from the bracket.





- As the panel is released from the upper bracket, the panel will need to be guided inwards toward the center of the unit. This will allow the bottom of the door to be released from the lower securement. This can be seen below.



- Repeat steps one through seven to remove the opposing panel set.
- To reassemble, place the inner panel back on the lower securement and repeat steps three through seven in reverse.

**⚠ WARNING**

A firm grasp of the door panels should be maintained at all times during the removal process. If you feel you are unable to handle the weight of the door panel, ask for help prior to attempting to operate on your own. Failure to do so may result in personal injury or harm.

**8. Storm Windows**

Each panel on the Lippert 3-Seasons door is equipped with adjustable storm windows to provide a barrier against the exterior elements. To operate, please follow the provided instructions (next column).

**OPERATING THE WINDOWS:**

- Locate the pinch release locks at each side of the glass pane.



- Pinch both release locks together at the same time.
- Once the locks release, raise or lower the window to the desired location. Be sure the pinch release locks are fully engaged once the desired position is achieved. Failure to do so may result in damage to the storm window.
- To close, reverse steps one through three.

**⚠ WARNING**

All glass panes must be in down position prior to travel. Failure to do so may result in the glass panels shattering during travel, damage to the RV and, or personal injury.

**D. COMPARTMENT AND ENTRY DOOR KEYS**

All entry doors and main compartment doors on the RV utilize the Keyed Alike system. One key will open any lock on the RV with the exception of the dead bolt found on the main entry and the garage entry doors. The deadbolt on the main entry door and the garage entry door have a separate key that can operate both locks.

If additional keys are needed, please contact your Dealer or Brinkley Customer Care.

## SEC.24 RAMP DOOR & PATIO

Your Brinkley RV is equipped with a MORryde ZERO-G ramp door system and patio assembly. The MORryde ZERO-G ramp door system is a gravity resistant, hingless assembly that is specially designed to be hassle-free when operating.

### + NOTICE

Your MORryde ZERO-G patio door is rated for 3000lbs when in “ramp mode” and 1500 lbs. in “patio mode.” Both ratings are calculated assuming an even weight distribution across the ramp door. These weights are static weights and are to never be exceeded.

The ramp door is also equipped with an anti-slip interior surface to aid loading and unloading vehicles from the garage area.

Within this section, you will find the instructions on how to operate the ramp door, set-up the patio assembly, and how to utilize their features.

### A. RAMP DOOR OPERATION

The ramp door can be opened from outside or inside the RV. The ramp door can be opened and rotated parallel to the ground, so it can be used as the patio floor. This position is known as the “patio position.” The ramp door can also be lowered all the way to the ground and used as a ramp. This position is known as the “ramp position.”

#### 1. Exterior Operation

To unlock your ZERO-G ramp door from outside the unit, you will need to insert the provided key into the ramp door release lock located on the lower right side of the ramp door jamb. Once the key is inserted, rotate the key counter clockwise. This motion will disengage the electronic latching system at the top of the door. Once you hear the locking mechanism release this means the electronic actuators have opened and the door will begin to open from its previously closed position.

For quick guide instructions, please see below.

#### OUTSIDE RAMP DOOR OPERATION:

1. Locate the provided ramp key and ramp door release lock. The photo below will show the location of the key insert relative to the ramp door. The ramp door release lock is covered by a black rubber protective cap. This cap must be removed to expose the



2. With one hand on the ramp door, insert the key and rotate counter-clockwise to release,





3. Guide the ramp door down to the desired position. If the support cables are connected to the ramp door, the door will only open to the patio mode position. To allow the door to fully rotate down to the ground, you must first disconnect the support cables from the ramp door on each side. Both positions are shown below.

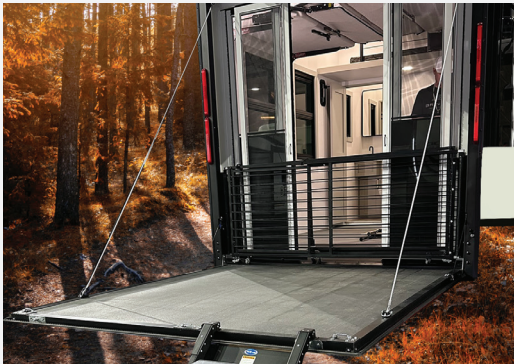

4. To close the ramp door, ensure the garage entry door is open. This will allow air to escape the garage as the ramp door closes.
5. Lift the ramp door back up into the closed position.
6. Forcefully push the ramp door firmly against the RV until a latching sound is heard.
7. Verify the door latched by pulling hard on the grab handle of the ramp door. If the door moves, reopen the door and repeat steps 4 through 6 until the ramp door securely closed.

### **⚠ WARNING**

The ramp door may start to fall open once the ramp door release lock is released with the supplied key. Be prepared to brace the door and gently guide the door to its desired position to avoid potentially damaging the door framing. Failure to do so may result in damage to the RV, personal injury, or death.

### **+ NOTICE**

To operate the ZERO-G ramp door system from outside the unit with the provided key, the unit must have power to operate the electronic actuators inside the ramp door jamb.

### **⚠ WARNING**

The garage entry door must be open for the ramp door to be properly closed. If this door is not opened, too much pressure will build in the garage area and in return, the ramp door will not securely close. As a result, damage to your RV, to other vehicles, personal injury, or death may occur.

## **2. Interior Ramp Door Operation**

If no power is available to the RV or if the ramp door lock is jammed, the ZERO-G ramp door will need to be operated from inside the RV. To do so, the yellow strap between the 3-Seasons door and ramp door must be located and pulled. For quick guide instructions, please see next page.

### **⚠ WARNING**

The ramp door may start to fall open once the actuation is initiated with the yellow pull strap. It is recommended to have someone capable of bracing the ramp door outside the coach to gently guide the ramp door to its desired position and avoid potentially damaging the door framing. Failure to do so may result in damage to your RV or personal injury.

## SEC.24 RAMP DOOR & PATIO

### INTERIOR GARAGE RAMP DOOR OPERATION:

1. Open both inner panels of the 3-Seasons door.



2. Locate and grab the yellow strap hanging from the ZERO-G ramp jamb and pull down until you hear the latch release.

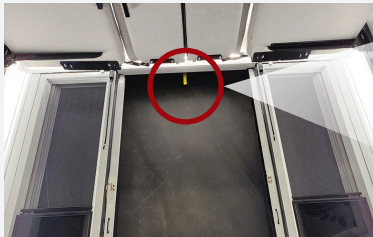

RELEASE STRAP

3. Once the latch releases, the door strikes will disengage and the door will slowly begin to open.
4. From the outside of the RV, guide the ramp door down to the desired position. Depending if the patio cables are connected, the ramp door may open to patio position or ramp position.
5. To close, ensure the garage entry door is fully open. This will allow pressure to be released as the ramp door closes.
6. Lift the ramp door back up into the closed position.
7. Push the ramp door firmly against the RV until a latching sound is heard.
8. Verify the door securely latched by pulling hard on the ramp door grab handle. If the door moves, open the door and repeat steps 4 through 6 until the ramp door properly closes.

### 3. Patio Position

When you would like to use the ramp door as a patio on the rear of the RV, the ramp door will need to be placed in the “patio position.” This position is where the ramp door is parallel to the ground with the supplied support cables attached to the ramp door. To place your ramp door into this position, the below instructions should be followed.

### PLACING THE RAMP INTO PATIO POSITION:

1. Open the garage door via the interior or exterior operation methods.
2. Locate and grab the patio cables that are connected to the gusset corners of the ramp door jamb. These are shown in the below photo.

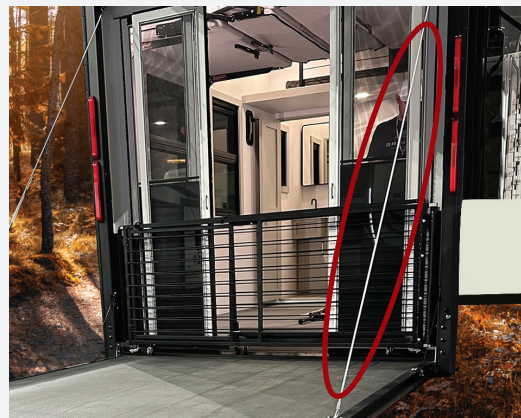

3. Once these cables have been located, gently guide the ramp door close to the parallel position to the ground.
4. The patio support cables can then be connected to the gussets circled in red below if they are not already attached. Generally these are never disconnected.



**⚠ WARNING**

Cables must be connected to the gusset plates on the jamb and the ramp door to hold the ramp door in the patio position.

5. Locate the patio connection plates found on either side of the ramp door.



6. Place the cable eyelet between the plate verticals and insert the provided D-ring in the correct orientation and ensure it is secured with the supplied cotter pin. Please see below.



7. Repeat steps 4 through 6 on the opposing side.

**⚠ WARNING**

Only use the ramp door in patio position if the suspension cables are properly connected at both previously mentioned locations. Failure to do so could result in injury, damage to the ramp door, ramp door system, or the RV itself. The patio rail kit is not designed to support the weight of the ramp door, occupants, or other items placed on the ramp door. The support cables are designed to carry the weight.

**4. Ramp Position**

When loading your RV with ATV's, golf carts, bikes, or any other equipment, the ramp door will need to be placed in the "ramp position." This position allows one end of the door to make contact with the ground, while the other remains connected to the RV. This displacement of the door creates the "ramp."

If the ramp door is closed and the cables are connected for patio position, the below steps will need to be followed to convert the placement to ramp position.

**PLACING THE RAMP INTO RAMP POSITION:**

1. Open the garage door via the interior or exterior operation methods.
2. Locate the patio connection plates found on either side of the ramp door. The plates connect the patio cables to the RV and will need to be released to place the ramp door into ramp position.



3. After locating these plates, remove the D-ring pin holding the cable in place.





## SEC.24 RAMP DOOR & PATIO

4. Repeat step 3 on the opposing side.
5. With both cables released, guide the ramp door down into ramp position. The ramp door is in ramp position when the leading or top edge of the ramp door engages the ground.



### B. PATIO KIT

Your Brinkley RV is equipped with a full patio assembly including stairs, a patio rail kit and integrated gate, led lighting, an awning, and a 3-Seasons door.

To fully assemble your patio, the below instructions should be followed.

#### SETTING-UP THE PATIO:

1. First begin by opening the ramp door into the patio position. See [Section 24A\(3\)](#).
2. Locate the patio steps. These steps are located in your off door (driver) side in the MORryde cargo tray. To mount the steps to the patio:
  - a. Press in the two push releases found on each side of the step rails and slide the rails over the connection posts (circled in red) located on the ramp door. As you release the push releases, you should hear the lock engage.

#### ⚠ CAUTION

Make sure you hear the latching mechanism of the steps engage prior to moving on to the next step. If you are questioning if the locks are engaged, try to lift up and pull the steps away from the ramp to see if they will release. The steps should not move if they are seated and locked correctly.

- b. Once in the locked position, adjust the leg height of the steps so that the step treads are parallel to the ground. To do this, locate and remove the leg pin. This is shown in the photo below.



c. The step treads will then need to be rotated in an upward and out motion to get them into position. Please see the photos below.



4. Now it is time to open and set up the rail kit. Carefully climb the steps onto the ramp door and locate the velcro (circled in red) on the patio rails and release the straps.



5. Starting with the first outermost section of the patio rail kit, carefully swing the rail towards the edge of the ramp door.



6. As the rail meets the edge of the ramp door, you will need extend the telescoping portion of the rail kit to the outermost corner of the ramp door. This is performed by grabbing the rail and guiding it towards the direction of the stairs.



7. Once the rail is fully extended, engage the latching mechanism at the end of the railing as shown in the picture below.

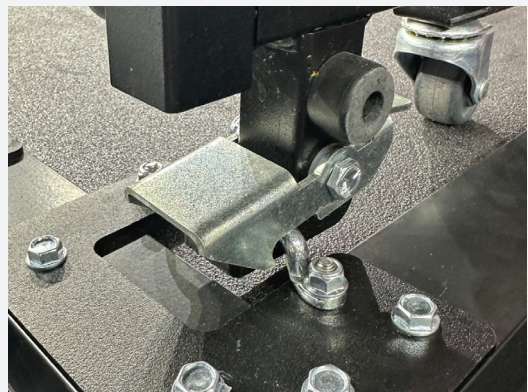



## SEC.24 RAMP DOOR & PATIO

8. Repeat steps 5 through 7 for the opposing rail. When complete, the rail should now be in the same position as what is displayed in the photo below.



9. The off door side rail also contains the rail kit portion for the front or top of the ramp door. Pivot the front rail into place and engage the latch as indicated in the below photo.

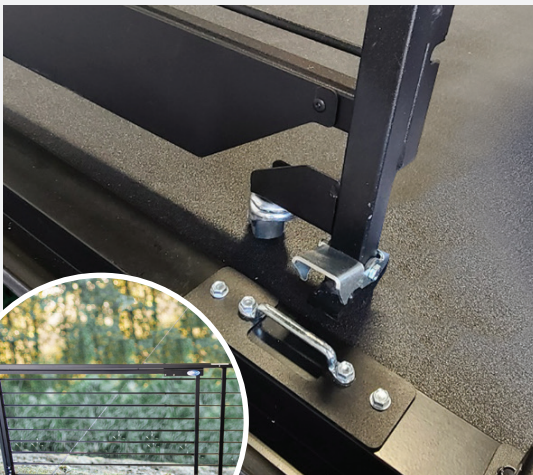

10. For safety, take a moment to check each rail. It is important to make sure each foot latch is properly seated over its designated floor securement before the patio is used.

11. Now that all rails are in place and secured via the foot latches, the gate can now be opened and closed. When the gate is in closed position, the gate latch should also remain in closed position. The latch is shown below.



### ⚠ WARNING

All components of the patio should be assembled in the manner in which the manufacturer describes. All moving parts should be verified that they are locked into place prior to using. Failure to follow these instructions may lead to damage to the RV, personal injury, or worse.

### ⚠ CAUTION

Patio components should only be used as intended by the supplier. For additional information, warnings, and instructions, please see the manufacturer's manual.

To stow the patio kit for transit, please follow the following steps.

**STORING THE PATIO:**

1. When closing the patio assembly, begin by making sure the Happijack bed is in travel mode. Please See [Section 10](#) for further details. The photo below shows this position.

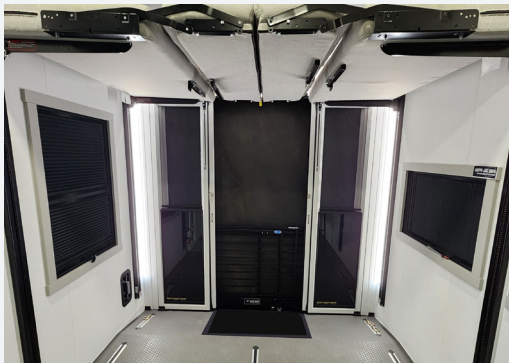

2. Close the inner 3-Seasons panels by sliding the inner panels together in the center of the opening.
3. Latch the doors together with the supplied latch to secure them for transport (see photo under step 4).
4. Make sure all 3-Seasons storm windows are in the down position. See [Section 23C\(8\)](#) for additional details.



5. Open the patio gate and pivot the gate until it reaches the main rail panel on the doorside of the RV. Once the gate meets the main rail panel, press the bottom portion of the gate rail against the outer patio rail until you hear the magnet make contact.

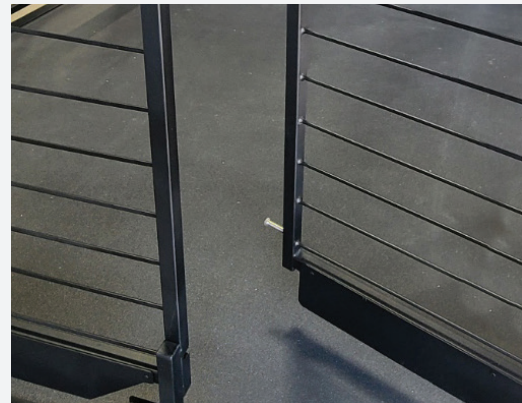

6. From there, start with the rail just left of the stairs (if you are facing the RV). Press downward on the foot latch to release the rail from the floor securement and pivot the rail panel until it meets the outer rail panel. You will need to press the bottom portion of the rail panel to ensure it makes contact with the securement magnet. You will hear once connection is made.

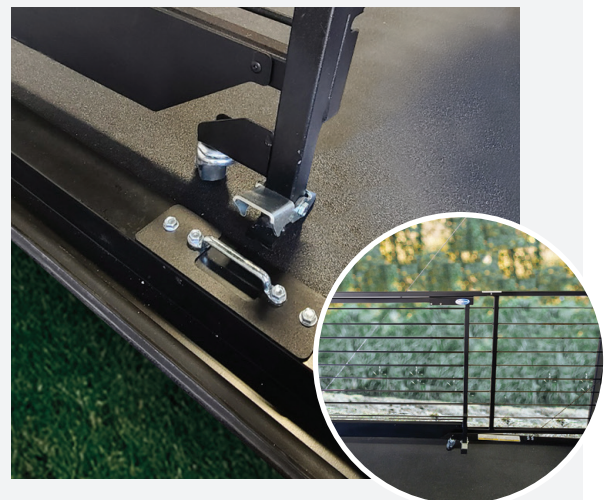



## SEC.24 RAMP DOOR & PATIO

7. On the off door (driver) side, press downward on the floor latch to release side rail from the floor securement. As the latch releases, pull the rail straight back toward the RV until you hear the detention pin engage.



8. Pivot the off door (driver) side rail towards the RV. You will need to gently lift the rail while moving it towards the RV until it lays flush with the 3-Seasons door.



9. Locate the next foot latch on the door (passenger) side rail and press the latch down to release while pulling the rail straight back towards the RV until you hear the detention pin engage.



10. Pivot the door side rail towards the RV until it meets the other rail. Once the off door (driver) side rail is close to the other, you will need to slightly lift the rail to set it into its proper closed position.



11. Prior to closing the ramp door, use the velcro strap to secure the two rails together.



12. Now that the rails are in the closed position, you will need to remove the steps.
- a. First fold the step treads into the upward position.



- b. Press the two push releases in, and lift the stair up.



- c. Before storing, the legs on the stairs will need to be fully retracted. This can be performed by removing the leg pins and sliding the legs to the last hole available and then reinserting the pin.



- d. Store the steps in the off door (driver) side MORryde cargo tray.
13. The last step is to close the ramp door. Prior to doing so, open the garage entry door. This will allow pressure to be released as the ramp door closes.
14. Lift the ramp door back up into the closed position.
15. Forcefully push the ramp door firmly against the RV until a latching sound is heard.
16. After the latching sound is heard, verify the door truly latched by giving it a tug. If the door moves, reopen the ramp door and repeat steps 4 through 6 until the ramp door properly closes.

**CAUTION**

Failure to lower the storm windows of the 3 seasons door may result in broken glass, damage to the RV, and/or personal injury



# SEC.25 ACCESSORIES

## A. INTERIOR ACCESSORIES

Within your RV, there are many features and accessories to improve your experience. These features include a pull-out pantry and spice rack, hidden dog dishes, an extendable island, silverware drawer, and much more.

### 1. Pantry

The design of the pantry was guided by weight limitations and not based on the volume of items. Please bear this in mind as you load and stock the pantry. To open the pantry, you will need to step on the release shown in the below photo and gently pull the handle to slide the pantry open.



This pantry can be used to store items you wish to take with you as you travel. The shelves within the cabinets were designed for common camping items such as paper plates, napkins, cookware, plastic cups, dry goods, etc. all of which are not heavy or bulky. Prior to traveling, it is best to make sure all loaded items are fully secure.

### TO ADJUST THE PANTRY SHELVES:

1. First determine the shelf you would like to adjust and its desired location.
2. Locate the push levers on the shelving track and apply pressure to them. This will allow you to move the shelf freely one side at a time.



3. Repeat this process on the opposing side.

### 2. Spice Rack

Next to the pantry, you will find a spice rack. To open the spice rack, grab the handle and pull towards you to open. Below is the spice rack in its opened position.



### 3. Silverware Drawer

Your RV is equipped with a hidden silverware drawer. This drop down silverware drawer is recessed in an overhead cabinet in the kitchen area. Circled in red, you will find the location of the silverware drawer in the G3500.



To operate, grab the handle and gently pull in a downward motion. This will allow the drawer to pivot open.



To close, simply push up on the handle until you feel the drawer seat into the closed position. Prior to traveling with your RV, it is important to make sure this drawer is properly closed.

### 4. Knife Drawer

Your RV is equipped with a hidden, magnetized knife drawer. This drop down drawer is located in an overhead cabinet within the kitchen. Circled in red, you will find the location of the silverware drawer in the G3500.



To operate, grab the handle and gently pull in a downward motion. This will allow the drop drawer to pivot open.

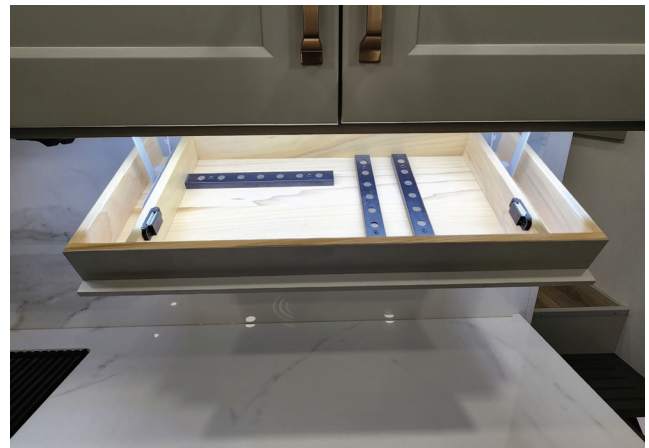

To close, simply push up on the handle until you feel the drawer seat into the closed position. Prior to traveling with your RV, it is important to make sure this drawer is properly closed.



## SEC.25 ACCESSORIES

### 5. Island Extension

Your RV is equipped with an extendable island feature. The island extension is located on one of the short ends of the island. Below you can see what the closed position looks like.



#### EXTENDING THE ISLAND:

1. Locate the extension found at one of the short ends of the island.
2. Grab the extension on both sides, near the top, and gently pull the top portion of the extension out. The extension will only slide-out about 2" (5.08 cm).



3. Pivot the extension top up so that it is parallel to the countertops.



4. Once the extension is in position, locate the support plate and gently pull it out.



5. To stow away, repeat these steps in reverse.

### 6. Cutting Board

Your RV is equipped with a cutting board that is stowed in the island on the side closest to the oven. As an example, the location of the cutting board in the G3500 is shown below.



To open, grab the handle and gently pull out.



To close, push inward on the drawer front attached to the cutting board.

### 7. Pet Food Bowls—Integrated into the Kitchen Island

Your RV is equipped with integrated pet water and food bowls. It is integrated into the steel base of the island.

Simply grab the front of the metal tray and pull it outward to reveal the pet bowls.



Push in on the front of the tray to close.

These bowls are removable for cleaning and collapsible for storage. The bowls need to be retracted and not contain food or water to retract the tray back into the island. Also be sure to remove all food and water from the bowls prior to travel to avoid spillage.

### 8. Bathroom Storage

Your RV is equipped sliding storage within the bathroom. The upper storage is very similar in operation and design as the pantry. The lower storage is a slide-out trash can.

To open either storage area, you will first need to locate the center lock shown below and rotate it 90 degrees. This will allow the doors to freely open. Prior to travel, both storage doors need to be closed and the lock needs to be engaged.

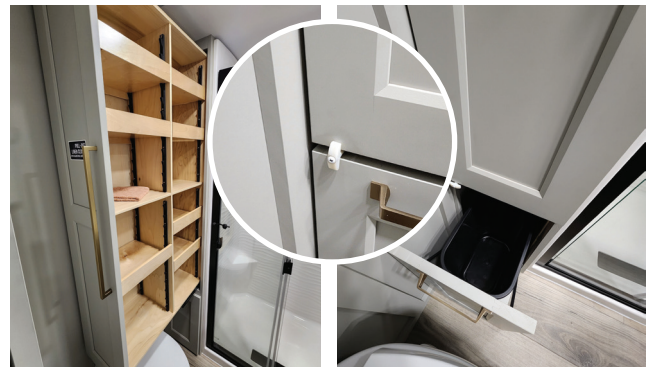

To adjust the shelving, please See [Section 25A\(1\)](#) for instructions.

### 9. Garage Hidden Storage

Within the garage area, there is an in floor storage compartment. This compartment is recessed within the floor and can be locked and unlocked with a key.

Below is the compartment and its location. In the close up, you can see the lock and the compression latch. To open the compartment, unlock the latch and press down on the latch to release the door.

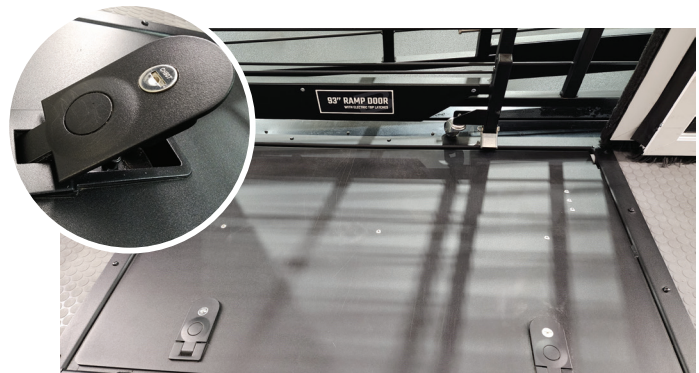



## SEC.25 ACCESSORIES

### 10. Recessed L-Track

Within the garage area of your RV, you will notice tracks in the floor. These tracks are known as L-tracks and are used to assist in securing your vehicles and equipment. L-track accessories can be moved along the track depending on the need.



## B. EXTERIOR ACCESSORIES

Just like the inside of your RV, the outside holds many features and accessories for your convenience. These features range from air hose reels, to a mini fridge, to exterior LED lighting, and much more.

### 1. Mini Refrigerator

Just to the right of your main entry step, you will see a small compartment door. Upon opening this door, you will reveal a 12-volt mini refrigerator. This mini refrigerator is great for canned beverages.



### 2. MORryde Cargo Tray

Underneath the pass-through storage compartment, you will find sliding storage trays. MORryde Cargo Trays are designed to create easy access to your camping gear and tools, while maximizing your storage space.

To open the cargo tray, you must unlatch the locking mechanism found at each end of the tray.



Prior to traveling with your RV, all stored items should be secured and trays must be placed back into the locked position.

### 3. Shore Cord Reel

On the off door (driver) side of your RV, just behind the full pass-through compartment, there is a smaller compartment door. Once opened, you will see the below electric cord reel. This reel is intended to assist in storing your shore cord effectively and cleanly.

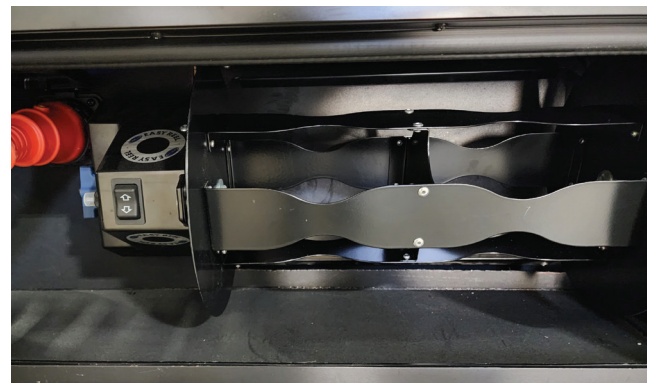

To operate this cord reel, make sure the shore cord is wrapped a minimum of one time around the reel to form tension. From there simply use the switch to wrap the reel.

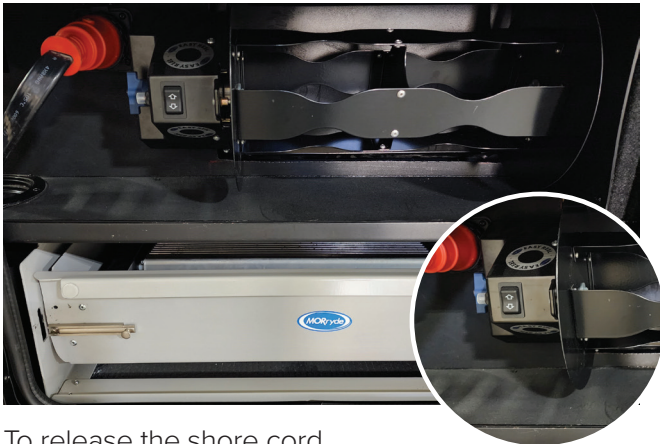

To release the shore cord, use the switch and guide the cord out until the full length of cord is freed from the reel.

**⚠ WARNING**

Do NOT utilize the 50 amp shore power cord while any portion of the cord remains wrapped around the cord reel. Utilizing the cord while it is coiled can result in overheating, melting the protective sheathing, or fire potentially resulting in damage to the cord, the RV, and could result in personal injury or death.

**4. Air Compressor**

On the off door (driver) side, near the rear of RV and just in front the fuel compartment, you will find an air compressor. This compressor is a one gallon (3.8 liter) air compressor capable of handling up to 135 psi (930.8 kPa). Below is a photo.



Please reference the manufacturer's manual for operating instructions and information.

**5. Air Hose Reel**

For convenience and ease, a retractable air hose has been installed on your RV. It is located on the off door (driver) side of the RV towards the rear of the unit.



To operate, open the locked accessory door and carefully pull the hose out. To retract the hose, lightly pull to disengage the lock and allow the reel to retract.

**6. Power Cord Reel**

For convenience and ease, a retractable power cord reel has been installed on your RV. It is located on the door (passenger) side of the RV towards the rear of the unit.



To operate, open the locked accessory door and carefully pull the extension out. To retract the extension, lightly pull to disengage the lock and allow the reel to retract.



## SEC.26 RV EXTERIOR CARE

### A. GENERAL

The exterior portion of the RV is composed of many materials including, but not limited to: Fiberglass, automotive paints, plastics, sealant, aluminum, and rubber.

The longer a foreign substance remains on the finish of the RV, the more likely it is to damage it. It is recommended that you keep the exterior of the RV cleaned and maintained on a continuous basis. This can be accomplished by frequently washing and waxing the RV with the recommendations outlined in the below sections.

The following materials may cause damage to the surface of the RV resulting in corrosion, staining, chemical spotting, and premature wear:

- Road dirt, dust, and debris Including, but not limited to, road salt, de-icing chemicals, tar, gravel, oils, and other automotive fluids.
- Tree sap, bird feces or droppings, and bugs.
- UV exposure, humidity, and moisture.
- Industrial fallout, hail, acidic rain, and other possible pollutants.

### B. EXTERIOR CLEANING

Frequently washing the RV can help to protect it against environmental elements, such as acids, debris, and/or salts commonly found in air, water, and snow, and de-icing chemicals.

- Any time the RV encounters foreign materials, the RV should be washed.
- Try to avoid parking under trees, near saltwater bodies of water, or in direct sunlight.
- When ice or snow is present, never scrape the surface of the RV to remove, always brush snow and ice off with a soft bristle snow broom.
- If chemicals or solvents such as anti-freeze, gasoline, oil, etc. encounter the surface of the RV, rinse the affected area immediately.
- Bird and insect droppings should be rinsed off daily.

### C. WASHING

- Never wash the RV in direct sunlight. Park in a shaded area and allow the RV surface to cool before washing.
- First spray the RV with water to remove loose dust and debris.
- Next, wash the RV.
  - Use a mild car wash detergent and water mixture.
  - Use a soft debris-free washing mitt or sponge.
  - Wash from the top down of the RV.
- Once fully washed, the RV should be thoroughly rinsed.
- Upon rinsing, immediately dry with a chamois or soft cloth.
- Joints, flanges, wiper seals, doors, etc. should be carefully hand cleaned to remove hidden or covered dirt and debris.
- **NEVER** use an automatic car wash on the RV.
  - Excessive heat may distort materials and cause resins to become damaged.
  - Excessive pressure may cause water to flood undesired areas within the RV.
- Avoid using high pressure water systems to clean the RV. This may force water into the RV.
- When using any form of pressure sprayer, extreme caution should be used near or around any door, attachment, window, vent, appliance, etc.
- Keep the tip of the sprayer roughly 16 inches or further away from the surface of the RV.
- If hazing or chalking occurs, wash, and wax a small trial area to see if luster returns.
- Have the RV inspected by your Dealer if the exterior becomes cracked or nicked.

## D. DURING COLD WEATHER

If the slide-out room, compartment door, or entry door becomes frozen shut, do not force it open. Doing so may result in damage to the seals, gaskets, and slide components. If seals become damaged, they will no longer be weatherproof.

### To open:

- Apply warm water on the gasket or seal to melt the ice. Do not use boiled or hot water.
- Once the ice melts and the door or slide-out can be opened, thoroughly dry all water present.

### + NOTICE

Salt and other chemicals utilized on roads during winter months may cause damage to the RV and should be rinsed immediately. Rust may form if it is not cleaned from the metal surfaces and will not be warrantable.

### When exposed to salts and other chemicals during winter:

- Rinse the under portion of the RV (frame, axles, axle hangers, pinbox, LP lines, etc.) and all other parts of the RV that may have been exposed.
- After rinsing the RV, dry all water from all doors, slide-outs, and rubber seals or gaskets.

## E. RV WAXING

The RV should be waxed once or twice a year, or when water no longer beads upon the surface of the RV. Take a soft cloth and apply a small amount of wax to the surface of the entire RV.

- Never wax in direct sunlight.
- If surfaces are warm, allow them to cool before beginning.

- Do not apply wax to weather stripping or rivets.
- If the wax stains the surface, remove with a warm water and a soft cloth.
- Once the wax is fully dry, hand buff the RV with a dry, soft cloth.
- Repeat this process until the desired results are obtained.

For additional information on graphic care, please see the manufacturer's PDF at <https://multimedia.3m.com/mws/media/9705400/qa-for-consumers-3m-wrap-film-series-1080-pdf>.

### + NOTICE

DO NOT use a buffing compound or buffer on the surface of the RV as it may damage the exterior surface. If further assistance is needed, please contact your local RV body professional.

## F. RV POLISHING

If the painted surfaces of the RV dull over time, are damaged, or lose their color, a mild polishing compound can be used. Polish a larger area than that of the damaged area to help to blend in the polished area. After the area has been treated with polish, thoroughly remove the polish from the surface and re-apply a coat of wax.

## G. DAMAGED PAINT

After returning from a trip, all surfaces exposed to the road or near the tires should be inspected for paint damage that may have resulted from debris. If painted areas become damaged, they should be touched-up as soon as possible with touch-up film or paint. To purchase touch-up films or paints, please reach out to your closest automotive facility capable of matching paint. Please also refer to [Section 26N](#) (next page) pertaining to the RV frame/chassis.



## SEC.26 RV EXTERIOR CARE

### H. PLASTIC COMPONENTS

To clean plastic components, use a soft cloth, sponge, or chamois with warm water. Refrain from using abrasive cleaning tools, soaps, or waxes as they may cause damage to the surface of the plastic components.

### I. CHROME PARTS (IF EQUIPPED)

To prevent spotting or corrosion from occurring on chrome parts, always pat dry when exposed to moisture. When washed, rinse with water, thoroughly dry, and apply a non-abrasive wax for protection. If the chrome becomes severely damaged or pitted, chrome polishes can be utilized.

### J. EXTERIOR ROOF

The Superflex Alpha Ply membrane and vents on the roof should be inspected and cleaned twice a year with a mild soap and water solution.

- When cleaning the surface of the roof, refrain from using sharp tools (such as a putty knife) that could puncture or tear the membrane.
- All areas should be cleaned with a medium scrub brush.
- Once fully clean, rinse with water and allow the surface to air dry.
- If seals need to be reapplied, clean the area with a non-abrasive household cleaner first (i.e., Spic-N-Span).
  - Always prep and re-seal an area **AFTER** the roof has already been washed.
  - Cleaners and solvents should **NOT** be used in the washing stage. Cleaners and solvents may damage existing seals or cause premature breakdown.

### + NOTICE

Never use petroleum distillates when washing the roof. This may cause irreversible damage.

### ⚠ WARNING

**When on the roof, do so with great caution and navigate the area on your hands and knees. This will help to distribute your weight and reduce your risk of falling. As the water and mild soap solution are applied to the roof material, it can become very slippery.**

### K. SIDEWALL VENTS

There are various vents and appliance access panels that will need to be kept clean and clear of debris and obstructions. Holding tank vents will also need to be regularly inspected for possible obstructions caused by birds, insects, leaves, etc.

### L. SEALANTS

There are many forms of sealants used on your RV including butyl tape, putty, encapsulated foam, silicone, roof sealant and Eternabond tapes. Each sealant has its own unique way to help protect your RV.

Although many seals do not have a set lifespan, due to environmental factors, deterioration may occur over time. If signs of deterioration are present, please replace the seal immediately to prevent possible damages.

Exterior sealants should be inspected every six (6) months and replaced as needed every year.

Please contact your Dealer or Brinkley RV Customer Care for a copy of the Brinkley RV Seals Guide.

**Dealer Expectation:**

- Inspect ALL sealants every three (3) months the RV is on lot and replace as needed.
- Replace all seals once a year as required as preventative care.
- Resolve any water damage that occurred due to the lack of preventative care.

**If water is present inside the RV, immediately inspect the RV for leaks. If the origin of the leak cannot be determined and remedied, have your Dealer inspect the RV right away. Failure to properly maintain the RV or to correct a leak may result in extensive damage to the RV and is not deemed warrantable.**

Please contact your Dealer or Brinkley RV with any questions, or concerns that you have.

**M. ROOF LADDER**

There is a roof access, side mount ladder provided with the RV and is stored within the pullout storage found under the main pass-through storage on the off door side (driver's side). This will allow you to gain access to the roof. The roof contains decking under the rubber roof membrane that will allow you to walk on the roof to perform maintenance. This should be performed with caution.

**⚠ WARNING**

**The installed ladder is capable of handling up to 300 lbs (136.08 kg). When in transit, no items should be attached to the ladder at any time.**

**N. RV FRAME/CHASSIS**

Road debris, rocks, automotive fluids, sand, salts, and other road chemicals may cause damage to the frame's exterior paint. As its' protective coating becomes compromised, the frame becomes susceptible to rust and other forms of deterioration.

Regularly inspect all exposed areas of the frame and repaint compromised areas after thoroughly cleaning.

**O. WINDOWS**

Condensation and heavy rains may allow water to accumulate within the window track. Regularly dry and clean this area to prevent mildew from forming.

The glass within the window can be cleaned using a glass cleaner and soft cloth or paper towel. After being cleaned, the glass should be dried with another soft, dry cloth.

1. Inspect the roof and all other surfaces for damage that may pose a threat for water to seep into the RV. Such leaks may go unnoticed until damage is already done.
2. Ensure all windows, roof vents, compartment doors, and entry doors are securely closed.

## SEC.26 RV EXTERIOR CARE

### P. RAMP DOORS AND PATIO RAIL KITS

The exterior of the ramp door should be cleaned in the same manner as the exterior walls of the RV. The interior of the ramp door can be cleaned with soap and water and a soft bristle brush to help remove dirt and debris from the interior textured surface.

The Patio Rail Kit should also be kept clean and free from dirt and debris. Warm soap and water can be utilized. Towel dry after cleaning. Lubricate moving parts as needed.

### Q. RV STORAGE PREPARATION

To help prevent problems from occurring, you should always prepare the RV before placing it in storage over extended periods of time. This preparation will not only protect your RV, but it will also make the process of removing the RV from storage much easier to accomplish.

1. Inspect the roof and all other surfaces for damage that may lead to water leaks or damage.
2. Ensure all windows, roof vents, compartment doors, and entry doors are securely closed.
3. Turn OFF the power to the refrigerator.
  - a. Once defrosted, the freezer and refrigerator should be cleaned.
  - b. Place baking soda and crumpled newspapers in the refrigerator to help eliminate odors.
  - c. Disconnect the ice-maker and drain the line.
4. Clean and empty the external mini refrigerator and place baking soda and crumpled paper inside the refrigerator to help eliminate odors.
5. Fully shut the propane cylinder valve(s).
6. Cover all external vents, exhausts, air conditioner, and outlets with mud dauber/rodent screens to prevent rodents from entering.

### THESE MUST BE REMOVED PRIOR TO CONTINUING USE.

7. **DISCONNECT** all external shore power.
8. Fully retract the leveling system and refrain from using while in storage.
9. Ensure all water tanks and water lines are drained.
10. Flush all holding tanks including the freshwater tank, gray tank, black tank, and the water heater.
11. Winterize the water system.

**Please see plumbing winterizing instructions in [Section 21](#).**

12. Use the main battery disconnect to disconnect all 12V power. Remove the battery from the RV and place on a battery maintainer for proper storage.



EXAMPLE OF A BATTERY MAINTAINER (CUSTOMER SUPPLIED)

13. Thoroughly clean the inside of the RV removing any foods to prevent attracting rodents.
14. Wash the exterior surfaces of the RV.
15. If possible, store the RV indoor, under a roofed location, or under a breathable RV cover.
16. For UV and weather protection, cover the tires with tire covers.
17. Drain both fuel tanks and fuel lines.
18. Run stabilizer through the generator and change the oil.

**+ NOTICE**

Before winter months, ensure the RV's plumbing system is winterized. Failure to do so may result in frozen pipes and costly damages.

---

**+ NOTICE**

Damage caused or created by rodents or insects is not warrantable. Please take proper measures to prevent infestation or entry.

---

**R. SNOW REMOVAL**

Throughout winter months, snow should be continuously removed from the top of your RV to help prevent possible damage from occurring.

**+ NOTICE**

Excessive snow and ice [8"+ (20.32 cm +) of snow or 2"+ (5.08 cm +) of ice] place additional stress and weight on the RV roof that should be removed immediately. This weight can be detrimental to the materials and structure of the RV. Continuously remove snow and ice as needed. Upon removing, do so with care to prevent damage to the roof, seals, vents, and appliances.

---



## SEC.27 RV INTERIOR CARE

### A. CLEANING THE INTERIOR

To increase the life of the RV, maintenance should be performed on a regular basis following the proper care procedures. In addition to this manual, please follow all instructions contained within the manufacturer's provided manuals.

#### + NOTICE

Only cleaning products recommended within the manufacturer's manuals and this manual should be used on your RV. Using improper chemicals and cleaning agents may result in surface damage within the RV. Always test a small, inconspicuous area with the cleaning agent before using upon the entire surface. Contact your Dealer or Brinkley RV Customer Care for additional information and assistance.

#### ⚠ WARNING

**NEVER use flammable agents or sprays to clean your RV.**

### B. TABLES, CABINETS, AND DRAWERS

- Regularly dust all hardwood surfaces including cabinet doors and drawers, tables, and cabinet fronts using a soft cloth and cleaning polish or mild recommended solution.
- Do not use silicone oils or ammonia-based products on any surface. Prolonged use will result in damage to the surfaces.
- Clean accidental spills as they occur.
- Avoid prolonged exposure to direct sunlight, high humidity, extreme cold, or high temperatures. Extreme conditions may result in damage to finish and/or wood products.

### C. WALL, CEILING, AND CABINET PANELING

- Use a solution of a mild soap and warm water.

- Always use a soft cloth or sponge.
- Refrain from using harsh cleaning agents as they may dull the surface color or cause micro-scratching. Always test cleaning agent in an inconspicuous area first.
- If a more aggressive cleaner is needed for stubborn dirt or grease, use an all-purpose cleaner.

### D. COUNTERTOPS

The main countertops in the RV are made of porcelain. Special care must be exercised to prevent permanent damage to the countertop edges and surfaces as follows:

- **ALWAYS** use hot protective pads under any hot pans, dishes, or heat producing appliances.
- **NEVER** use a knife or sharp object directly on the countertops. ALWAYS utilize a cutting board.
- **NEVER** use harsh chemicals or cleaners (i.e., drain cleaners, oven cleaners, grease removers, etc.).
- **NEVER** mix bleach and other cleaning agents.

Many commercial surface cleaners and cleaning solutions can be used to remove residue and dirt. Avoid the use of window cleaners as many glass solutions leave a waxy buildup that will dull the surface appearance. Utilize a damp microfiber cloth to clean the surface and dry with a dry microfiber cloth or towel to remove residual cleaner left behind. All countertops should be disinfected on a regular basis. This can be accomplished with disinfectant wipes or diluted household bleach (100:1, one hundred parts water to one part bleach).

### E. VINYL FLOORING

Always test a small, inconspicuous area with the cleaning agent prior to using on the entire surface. If the surface dulls or pulls, discontinue use immediately to prevent further damage. Please see the cleaning guide on the next page for further instructions.

## HOW TO TREAT STAINS, SPILLS & SCUFFS

Follow the remedies in order. Unless instructed otherwise, use a clean cloth or towel with the recommended liquids. Always rinse the affected area with clean water after treatment.

### STAINS AND SPILLS

|                        |                      |                  |       |
|------------------------|----------------------|------------------|-------|
| Acids, Alkalis         | Dye, Dye Markings    | Iodine           | Vomit |
| Blood                  | Food, Candy          | Mercurochrome    |       |
| Ketchup, Mustard       | Fruit & Fruit Juices | Rust*            |       |
| Cleaners, Strong Soaps | Grass                | Urine, Excrement |       |

### REMEDY

- Scrub area with Congoleum Bright 'N Easy No-Rinse Cleaner at full strength.
- Rub area with a 10 to 1 dilution of water to liquid bleach.
- Rub area with isopropyl alcohol.\*\*

*\*If rust stain does not respond, use lemon juice or a cream of tartar solution.*

### PAINT AND SOLVENT SPILLS

|                     |          |              |             |
|---------------------|----------|--------------|-------------|
| Dry Cleaning Fluids | Lacquer  | Latex Paints | Nail Polish |
| Oil-Based Paints    | Solvents | Varnish      | Wood Stains |

### REMEDY

1. If substance is dry, gently peel it from the floor (avoid sharp instruments that could scratch floor).
2. Scrub area with Congoleum Bright 'N Easy No-Rinse Cleaner.
3. Rub lightly with mineral spirits, isopropyl alcohol or lighter fluid.

### SCUFFS & SMUDGES

|                   |         |
|-------------------|---------|
| Rubber Heel Marks | Scuffs  |
| Shoe Polish       | Smudges |

### REMEDY

There are several methods for removing scuffs on satin-gloss and matte floors. For matte-gloss floors, use recommended methods #1 and #3 only. For satin-gloss floors, all of the listed methods for removal are recommended, depending on the severity.

- Spray Fantastik® Cleaner on the scuff. Let stand for 10-15 seconds and then remove with a sponge or cloth.
- Using a damp sponge, rub scuffed area with a polishing cleaner such as Soft Scrub®. Rinse with a sponge or cloth.
- Wipe scuff with lighter fluid\*\* applied with a clean cloth.
- With a rubbing motion, apply a car polish/cleaner such as No. 7® or similar product on the area, then rinse thoroughly.
- Remove stubborn scuffs with a mechanical buffer equipped with a lamb's wool pad.

*\*\*Caution: Isopropyl alcohol, lighter fluid, mineral spirits and paint thinner are flammable solvents. Carefully read and follow cautionary information on label. Keep traffic off treated area for 30 minutes.*

## SEC.27 RV INTERIOR CARE

Sweep or vacuum regularly to remove dirt and grit that can abrade, dull, or scratch your floor. Do not use a vacuum with a beater brush, because it may damage the floor's surface. Wipe up spills promptly with a damp cloth or mop. For a more thorough cleaning, use a non-detergent based resilient floor cleaner or a mild soap and water mixture.

### F. DINETTE TABLE, DINETTE CHAIRS

#### 1. Portable Dinette Table

The dinette table is designed to seat up to four to six people. Prior to traveling, the dinette table must be broken down and secured back into its storage location. Securing the table will prevent damage from occurring while traveling. The dinette table is made of laminated wood and should only be cleaned using cleaners that are safe for MDF or vinyl products.

#### 2. Bar Stools

There are two bar stools supplied with your RV. They are stored at the island in the main kitchen area. The bar stools are comprised of metal legs and a vinyl seat. The seat should only be cleaned with products suitable for vinyl cleaning. You should test the cleaner on an inconspicuous area first to ensure that the cleaner does not permanently damage the vinyl or change the color of the seat.

### G. FURNITURE UPHOLSTERY

Furniture upholstery should be cleaned and maintained on a regular basis. This can be performed by wiping the surfaces with a soft damp cloth or by vacuuming with a soft bristle attachment. Please see the information outlined within this manual and also in the manufacturers' manuals.

#### 1. Fabric

Brinkley RV is utilizing Richloom Tough Collection fabrics for the sofa, ottoman, and bedspread.

For proper care and maintenance, please see the below instructions.

#### **RICHLOOM TOUGH—PROPER CARE/ CLEANING GUIDELINES:**

- Both PVC and Polyurethanes should be cleaned with a mild, water-based shampoo or soap.
- More stubborn stains can be cleaned with a mild, non-alcohol based, cleaning fluid.
- Rinse with clean water after.
- Once cleaned and rinsed, pat dry.

All fabrics are also treated with Fortress, a proprietary stain resistant. They recommend blotting any stains with a paper towel to remove excess spills. Then, prepare a mixture of ¼ cup (59.15 ml) mild detergent with 1 gallon (3.78 liters) of water. Spray the mixture on the area and blot again. Repeat until clean. Allow the area to air dry.

For additional information and recommendations, please refer to the manufacture's manual.

#### 2. Vinyl

When vinyl is stained, it should be professionally cleaned only as recommended.

#### **CLEANING VINYL—LIQUID SPILL NO STAIN:**

- Gently pat dry with paper towel or a soft cloth.
- Use a water-based cleaner.
- Always pat clean, never rub or oversaturate the area.
- **NEVER** use solvents or harsh chemicals. Adverse reactions may occur to the backing of the vinyl if used.
- **NEVER** dry clean vinyl components. Adverse reactions may occur with use causing the backing of the vinyl to shrink and become brittle.

For additional information and recommendations, please refer to the manufacturer's manual.

## + NOTICE

Using other cleaning methods on vinyl other than what is recommended may produce undesired results and damage to the upholstery items. If this damage occurs, it is not warrantable.

### 3. ABS Plastic

ABS plastic components will remain composed and only require to be dusted and cleaned on occasion. This can be accomplished with a soft, damp cloth (i.e., drain lines, plastic trims, plastic covers, vents, etc.).

- **NEVER** use abrasive soaps, compounds, or cleaning agents to clean ABS plastic components.
- **AVOID** the use of citrus, acidic, or D-Limonene containing solutions; such cleaners are capable of damaging the ABS plastic material.

## I. DÉCOR

### 1. Glass Décor

Glass cleaner should be used to remove smudges, smears, and spots on the glass décor found within the RV. If there is decorative etching or frosting on the glass, be sure to clean with care in that given area.

### 2. Window Treatments

For the trim encompassing the windows, dust periodically with a soft cloth and a polish or mild solution. The trim is painted hardwood. Be sure that any cleaners utilized are compatible with painted wood product.

### 3. Blinds and Shades

Blinds and shades should be occasionally dusted using a vacuum and soft brush attachment or a soft cloth.

## J. SHOWER WALLS

The shower walls within the RV should be cleaned with a mild solution of soap and warm water. **NEVER** use abrasive soaps, compounds, or cleaning agents to clean the shower walls.

## K. SINK AND SHOWER FIXTURES

A mild soap and warm water mixture should be used to clean the sink and shower fixtures. If hard water spots are present, use a vinegar and warm water solution to clean.

## L. STAINLESS STEEL SINK AND APPLIANCES (IF EQUIPPED)

When cleaning stainless steel products, please see the below instructions:

1. Use a soft cloth dampened by a solution of mild soap and warm water.
  - a. Never use abrasive soaps, compounds, cleaning agents, scouring pads, or steel wool.
  - b. Some glass cleaners or cleaners made for stainless steel can also be used. Always perform a trial cleaning when using new products.
2. Carefully wipe the surface, cleaning with the grain of the steel and not against it.
3. Thoroughly rinse the cloth and repeat this process until the appliance surface is clean.
4. Pat dry the surface with a paper towel or dry soft cloth.



# SEC.28 MAINTENANCE

## A. MAINTENANCE CHECKLIST

Below, you will find a quick reference checklist of all the suggested items that should be regularly inspected and maintained. In addition to this provided checklist, please review the manufacturer's manual for additional information, instructions, warnings, and maintenance routines.

### 1. Prior to Your First Trip in Your RV

- **INSPECT** and reseal as needed.
- Ensure the propane system is properly inspected for leaks by your Dealer.
- Check tire pressure and torque on all wheel lug nuts. See [Section 5J](#).
- Clean and sanitize the freshwater tank and system. See [Section 21O](#).
- **TEST** all safety alarms within the RV. See [Sections 4E, 4F, and 4G](#).

- Refer to [Section 4](#) for additional information and instructions.

### 2. Each Trip

- **INSPECT** the seals and re-seal as needed.
- Ensure the auxiliary battery is fully charged and healthy.
- Verify running lights operate.
- **CHECK** all tire pressures and wear. Don't forget to check the spare. Tire pressure should be checked **BEFORE** the RV is traveled with, or while they are "cold." See [Section 5E](#).
- **CHECK** the torque of all wheel lug nuts. See [Section 5J](#).
- **TEST** the braking system of the RV and the tow vehicle. See [Section 7C](#).
- **TEST** all safety alarms and form a Family Safety Plan. See [Section 4](#).

| MAINTENANCE ITEM   | EVERY TRIP | MONTHLY | EVERY 3 MONTHS | EVERY 6 MONTHS | ANNUALLY | BEFORE/AFTER STORAGE | PROCEDURE TO BE PERFORMED:  |
|--------------------|------------|---------|----------------|----------------|----------|----------------------|---|
|                    |            |         |                |                |          |                      | MAINTENANCE SCHEDULES ARE MINIMUM REQUIREMENTS. EXTENDED USE, EXTREME TEMPERATURES, HIGH HUMIDITY OR OTHER EXTREME CONDITIONS WILL REQUIRE MORE FREQUENT MAINTENANCE. |
| APPLIANCES         |            |         |                |                | X        | X                    | CLEAN AND SANITIZE  |
|                    |            | X       |                |                |          | X                    | MAKE SURE BURNER TUBES/VENTS ARE CLEAN/UNOBSTRUCTED   |
|                    |            |         |                |                | X        | X                    | CHECK SETTINGS AND ADJUSTMENTS PER MANUFACTURER GUIDE   |
| AWNINGS            |            |         |                |                | X        | X                    | CLEAN MOVING PARTS AND APPLY SILICONE OR TEFLON BASED DRY LUBE  |
|                    |            |         |                |                |          | X                    | WASH WITH WARM WATER AND MILD DETERGENT   |
| AXLES/ SUSPENSION  | X          |         |                | X              |          | X                    | CLEAN MOVING PARTS AND APPLY SILICONE OR TEFLON BASED DRY LUBE  |
|                    |            |         |                | X              |          | X                    | WASH WITH WARM WATER AND MILD DETERGENT   |
| BAGGAGE DOORS      |            |         | X              |                |          | X                    | SPRAY LOCK TUMBLERS WITH DRY GRAPHITE   |
|                    |            | X       |                |                |          | X                    | CONFIRM THAT DOORS SEAL TIGHT AND ARE NOT LEAKING   |
| BRAKES/ WHEEL HUBS |            |         |                |                | X        |                      | CHECK AMP DRAW/SHOE WEAR/ADJUSTMENT (SEE MFG. SPECS)  |
|                    |            |         |                |                | X        |                      | LUBE BEARINGS EVERY 12 MONTHS/12,000 MILES (AS REQUIRED)  |
|                    |            |         |                |                | X        |                      | HAVE BRAKES AND HUBS INSPECTED BY A CERTIFIED RV SERVICE TECHNICIAN   |

| MAINTENANCE ITEM           | EVERY TRIP | MONTHLY | EVERY 3 MONTHS | EVERY 6 MONTHS | ANNUALLY | BEFORE/AFTER STORAGE | PROCEDURE TO BE PERFORMED:  |
|----------------------------|------------|---------|----------------|----------------|----------|----------------------|---|
|                            |            |         |                |                |          |                      | MAINTENANCE SCHEDULES ARE MINIMUM REQUIREMENTS. EXTENDED USE, EXTREME TEMPERATURES, HIGH HUMIDITY OR OTHER EXTREME CONDITIONS WILL REQUIRE MORE FREQUENT MAINTENANCE. |
| ELECTRICAL SYSTEM          |            |         | X              |                | X        | X                    | TEST ALL GFCI OUTLETS   |
|                            |            |         |                |                | X        | X                    | SERVICE GENERATOR (IF EQUIPPED) PER MANUFACTURER'S MANUAL   |
|                            | X          |         | X              |                |          | X                    | CHECK AND SERVICE BATTERIES   |
| ENTRY DOOR(S)              |            |         | X              |                |          | X                    | LUBE HINGES WITH SILICONE OR TEFLON BASED DRY LUBE  |
|                            |            |         | X              |                |          | X                    | ADJUST SCREEN DOOR AND LATCH  |
|                            | X          |         |                |                |          | X                    | CHECK DOOR LATCHES AND LOCKS FUNCTION PROPERLY  |
| EMERGENCY EGRESS WINDOW(S) | X          | X       |                |                |          | X                    | OPEN AND CLOSE THE EMERGENCY EGRESS WINDOW(S) EVERY TRIP  |
| ENTRY STEPS                |            |         |                | X              |          | X                    | CLEAN AND APPLY SILICONE OR TEFLON BASED DRY LUBE   |
| EXTERIOR FIBERGLASS/METAL  |            |         |                | X              |          |                      | APPLY NON-ABRASIVE WAX (EXCEPT ON DECALS)   |
|                            |            |         | X              |                |          |                      | WASH WITH WARM WATER AND MILD DETERGENT   |
| FRAME/ UNDERBELLY          |            |         | X              |                |          | X                    | CHECK FRAME FOR CHIPPED PAINT AND RUST, REPAINT AS NECESSARY  |
|                            |            |         |                |                | X        | X                    | CHECK FOR DAMAGE, LOOSE WIRES AND DEBRIS. CLEAN AS NECESSARY  |
| HITCH/COUPLER              |            |         |                |                | X        | X                    | CHECK FOR DAMAGE AND WEAR. CLEAN AND LUBRICATE (WITH GREASE)  |
| LP SYSTEM                  |            |         |                |                | X        |                      | HAVE SYSTEM TESTED FOR LEAKS BY A QUALIFIED DEALER  |
|                            |            |         |                |                | X        |                      | PRESSURE  |
| PLUMBING SYSTEM            | X          |         |                |                | X        |                      | DRAIN FRESH WATER HOLDING TANK AFTER EVERY TRIP. SANITIZE ANNUALLY (OR AS NEEDED).  |
|                            | X          |         |                |                |          |                      | DRAIN AND FLUSH BLACK AND GRAY WATER HOLDING TANKS  |
|                            |            |         |                |                | X        | X                    | WINTERIZE SYSTEM BEFORE STORAGE (IN COLD CLIMATES)  |
|                            |            |         | X              |                | X        | X                    | CHECK HOSES, FITTINGS, AND PIPES FOR LEAKS. TIGHTEN AS REQUIRED   |
| ROOF AND ROOF ATTACHMENTS  |            |         |                | X              |          | X                    | CLEAN ROOF WITH WATER AND MILD DETERGENT  |
|                            |            |         |                |                | X        | X                    | CLEAN AND LUBE ROOF VENT MECHANISMS WITH LIGHT OIL  |
| SAFETY EQUIPMENT           |            |         |                | X              |          |                      | TEST AND CHECK FIRE EXTINGUISHER FOR PROPER CHARGE  |
|                            | X          | X       |                |                |          | X                    | TEST AND CONFIRM EMERGENCY EGRESS WINDOW(S) FUNCTION PROPERLY   |
|                            | X          |         |                | X              |          | X                    | CHECK OPERATION OF DETECTORS – RECHARGE AND REPLACE BATTERIES EVERY 6 MONTHS IF EQUIPPED  |
| SLIDE ROOMS                | X          |         |                |                |          |                      | CHECK SLIDE ROOF FOR DEBRIS – CLEAR AS NECESSARY  |
|                            |            |         |                |                | X        |                      | SLIDE-OUT ROOM ADJUSTMENT PERFORMED BY A CERTIFIED RV SERVICE TECHNICIAN  |
|                            | X          |         | X              |                |          | X                    | CHECK AND CLEAN ALL SEALS   |
| WHEELS AND TIRES           | X          | X       |                |                |          | X                    | CHECK TIRE INFLATION PRESSURE (SEE TIRE LABEL)  |
|                            |            |         | X              |                |          | X                    | INSPECT TIRES FOR WEAR/DAMAGE/ETC.  |
|                            | X          |         | X              |                |          | X                    | CHECK WHEEL LUGS FOR PROPER TORQUE  |

## A. AIR CONDITIONER (ROOF)

### 1. A/C Will Not Operate

#### **⚠ WARNING**

**Working with any electrical system or appliance can be dangerous due to the risk of electrical shock. It is recommended that all inspections and repairs be performed by your Dealer or an authorized service location.**

---

- Ensure there is proper power supplied via an external shore power.
- Make sure the A/C is ON.
- Inspect all fuses and breakers found within the power center.
- Follow any other troubleshooting suggestions provided within the manufacturer's manual.

If the A/C is still inoperable, please contact your Dealer to inspect and repair as needed.

### 2. A/C Operates, but Coil Freezes and Compressor Cycles Prematurely

- Control setting may be set too low, causing compressor to cycle. Adjust as needed.
- Make sure there are no obstructions in the intake or exhaust.
- Clean the filter as needed.
- Inspect the intake baffle to ensure it is properly seated and not leaking or mixing with the output.
- Have your Dealer inspect coolant levels.

If the A/C is still not operating correctly, please contact your Dealer to inspect and repair as needed.

### 3. A/C Does Not Effectively Get Cold

- Begin operation of the A/C at the beginning of the day before temperatures rise.
- Offset "heat gain" effectively by:
  - Closing all windows and blinds.
  - Keep entrance doors closed.
  - Utilize the awning.
  - Avoid the use of heat-producing appliances as much as possible.
  - See [Section 17B](#).
- Ensure the outside coil is not obstructed or damaged.
- Ensure there is sufficient power to the RV.
- Have your Dealer verify the voltage at the A/C unit.

If the A/C is still not operating correctly, please contact your Dealer to inspect and repair as needed.

## B. ELECTRICAL POWER

### 1. No 12-Volt Power

- Verify no fuses are blown at the 12-volt distribution panel.
- Verify no fuses are blown at the 12-volt converter.
- Make sure that both battery disconnects are in the ON position.
- Make sure the battery is charged and healthy.
- Check the battery connections and terminals to ensure they are properly secured.

If there is still no 12-volt power in the RV, please contact your Dealer to inspect and repair as needed.

## 2. No 120-Volt Power While Utilizing Shore Power

- Make sure the breakers at the shore power pole are not tripped and make sure others in the area have power.
- Verify no breakers found within the power center have been tripped.
- Verify the GFCI is not tripped.
- Ensure your power cord is securely attached at the pole and to the RV.
- Have the park attendant verify that there is power at the shoreline receptacle.

If there is still no power within the RV, first contact the park maintenance team to ensure power is being properly supplied to the RV. If the problem persists please contact your Dealer to inspect and repair as needed.

## 3. No 120-Volt Power While Utilizing Inverter Power

- First complete all steps found under **No 12-volt Power**.
- Verify no breakers found within the power center have been tripped.
- Ensure the inline inverter fuse is not blown
- Verify all molex connectors at the inverter are properly seated and proper connection is being made.
- Then complete all steps found under **No 120-volt Power by Shore Power**.

If there is still no power within the RV, please contact your Dealer to inspect and repair as needed.

## 4. No 120-Volt Power While Utilizing Generator

- First follow all steps found in [Section 291](#).
- Ensure the breakers at the generator are not tripped.

- Verify no breakers found within the power center have been tripped.
- Verify the GFCI is not tripped.

If there is still no power within the RV, please contact your Dealer to inspect and repair as needed.

## C. FURNACE

### **WARNING**

**If the furnace is not functioning, do not attempt to make repairs or adjustments. Turn off the thermostat and the LP supply at the cylinders. All inspections and repairs should be performed by your Dealer or an authorized service location.**

### 1. Furnace Does Not Ignite and/or Cycles Frequently

- Ensure there is sufficient propane within the cylinders.
- Remove possible obstructions in or on the furnace exhaust.
- Inspect the furnace fuse within the power center.
- Check that the return air is not obstructed. Items stored in front of the return should be relocated.
- Ensure all heat registers are open and unobstructed.
- Ensure that sufficient power is being supplied to the furnace.

If the furnace is still not functioning properly, please contact your Dealer to inspect and repair as needed.



## SEC. 29 BASIC TROUBLESHOOTING

### D. INTERIOR LIGHTS

#### 1. If Lights Flicker

- The converter may be over-heating.
  - Reduce converter load by only operating appliances and lights that are needed.
  - Open the compartment to allow for additional ventilation.
- Check the wire connections at the switch and at the light to ensure they are not loose.

If issue persists, please contact your Dealer to inspect and repair as needed.

#### 2. Lights Dim or are Half Bright

- Ensure sufficient power is being supplied
- Check for low battery voltage and recharge if needed.
- Check for loose connections. Loose connections can cause a weak or lost ground connection.
- Have the converter inspected by your Dealer.

If issue persists, please contact your Dealer to inspect and repair as needed.

### E. MICROWAVE

#### 1. Will Not Operate

- Make sure the door is properly closed.
- Reset the time and select START.
- Check for sufficient power supply.
- Inspect the breaker to make sure that it was not tripped.

If issue persists, please contact your Dealer to inspect and repair as needed.

### F. MONITOR PANEL

#### 1. No Lights at Control Panel When Switch is Pressed

- Ensure proper power is being supplied.
- Ensure the fuse behind the panel is not blown.

- Check the mini fuses and breakers in the front compartment.
- Have the panel tested by your Dealer.

If issue persists, please contact your Dealer to inspect and repair as needed.

#### 2. Holding Tank Lights Deliver False Readings

- Verify the tank is empty.
- Clean any possible debris or build-up on the probe sensor.
- Clean and flush the tank by using a solution of two-parts vinegar mixed to one-part water.
- Repeat as needed.

If issue persists, please contact your Dealer to inspect and repair as needed.

### G. OUTSIDE RECEPTACLE

#### 1. No Power to Exterior Receptacles

- Make sure the RV is properly connected to external shore power.
- Check the breaker at the generator (Customer Supplied).
- Ensure the GFCI receptacle was not tripped.
- Check the breaker found within the power center.

If issue persists, please contact your Dealer to inspect and repair as needed.

### H. OVEN

#### 1. Oven Slow to Warm, Poor Baking, Poor Ignition of Burners, Pilots Won't Stay Lit, Top Burners Popping Sound, Carbon on Pilot Shield or Burner Flame Too Low or Too High

Have your Dealer check the Pressure Regulator for the LP system. If issue persists, please contact your Dealer to inspect and repair as needed.

## 2. Top Burner or Oven Burner Won't Light or Won't Stay Lit

- Ensure top burners are properly set and aligned along with the flash tubing.
- With a toothpick, clean any possible clogged burner ports.
- Follow any other troubleshooting and maintenance suggestions provided within the manufacturer's manual.

If issue persists, please contact your Dealer to inspect and repair as needed.

## 3. Gas Smell

- Make sure the oven is not overloaded with food. Overpacking the oven leads to improper circulation which will cause a build-up of gas.
- Check connections using a leak detector solution (i.e., Dawn dish soap and water solution).

If issue persists, shut off the gas supply immediately and contact your Dealer to inspect and repair as needed.

# I. GENERATOR

## 1. Starter Engages When Holding Start Button, but Generator Does Not Start

- Ensure the generator has sufficient fuel. Generator is inoperable if the tank is under ¼ full.
- Check the oil level and correct as needed.

If issue persists, please contact your Dealer to inspect and repair as needed.

## 2. If Generator Start Button is Pushed, and Nothing Happens

- Ensure battery disconnect is not engaged.
- Check 12-volt fuse on generator.
- Check the breaker found at the generator.

If issue persists, please contact your Dealer to inspect and repair as needed.

## 3. Generator Starts, but Lacks Sufficient Power Supply

- Check the breaker at generator.
- Check the main breaker within the RV.

If issue persists, please contact your Dealer to inspect and repair as needed.

## 4. Generator Makes Clicking Sound When Attempting to Start

- Check battery voltage and recharge if needed.
- Check for poor ground or battery connection.

If issue persists, please contact your Dealer to inspect and repair as needed.

# J. PROPANE GAS

## 1. Smell of Gas in or Around Unit

- Ensure propane cylinders are not overfilled.

If issue persists, please contact your Dealer to inspect and repair as needed.

### **WARNING**

Working on the propane system, or with propane can be quite dangerous. Always have LP related repairs performed by your Dealer or a qualified service representative.

### **DANGER**

#### IF YOU SMELL PROPANE:

1. Extinguish all open flames, pilot lights, smoking materials, etc.
2. Refrain from touching any electrical switches.
3. Shut off the propane supply at the LP bottles.
4. Ventilate the RV by opening all doors, windows, and vents.

5. Remain at a safe distance from the RV until all odor clears.
6. Have the propane system inspected and repaired as needed before continuing use.

Failure to comply with these instructions may result in explosion of the RV leading to serious injury or death.

---

### K. REFRIGERATOR

#### 1. Control Panel Lights Are Not Illuminating

- Ensure there is proper power being supplied to the RV.
- Check the battery voltage and recharge as needed.
- Check breaker found within the power center.

If issue persists, please contact your Dealer to inspect and repair as needed.

#### 2. Lights Are Illuminating, but Not Properly Cooling

- Ensure there is sufficient power being supplied to the RV via external shore power.
- Make sure the refrigerator is level.
- Allow sufficient time for the refrigerator to cool. Loading chilled and frozen foods will help to cool the unit faster.

If issue persists, please contact your Dealer to inspect and repair as needed.

#### 3. Frost Buildup on Evaporator Fins

- Allow the freezer and refrigerator to thaw.
- Refrain from overloading the provided area. Airflow and circulation are vital for proper cooling and to prevent frost buildup.

If issue persists, please contact your Dealer to inspect and repair as needed.

### L. RUNNING LIGHTS

#### 1. Running Lights Not Operating

- Check the fuse to ensure it is not blown.
- Check wiring connections.
- Replace the light as needed.

If issue persists, please contact your Dealer to inspect and repair as needed.

### M. SLIDE-OUT

#### 1. Runs In and Out Slowly, Binds, and/or Squeaks

- Ensure sufficient power is supplied.
- Lubricate slide-out rollers and gear pack (through frame slides only) with dry silicone spray lubricant.

If issue persists, discontinue the use of the slide-outs and contact your Dealer to inspect and repair as needed.

#### 2. Water is Entering at the Rear Corners

- Verify that the exterior seals are making proper contact with the slide-out box. Seals may be flipped in the wrong direction.
- Ensure the seals are clean and free of any obstructions, dirt, or debris.
- Make sure the weep hole found in the slide pan is clean and unobstructed.

If issue persists, please contact your Dealer to inspect and repair as needed.

#### 3. Room Will Not Move In or Out

- Ensure there is a sufficient power source.
- Verify battery voltage and recharge as needed.
- Check the auto-resetting mini-breaker located in the front fifth wheel bulkhead compartment. See the manufacturer's manual for additional information.

If the issue persists, please contact your Dealer to inspect and repair as needed.

## N. TERMINATION VALVE

### 1. Leak at Termination Valve

- Ensure debris is not seated within valve.
- Replace valve as needed.

If the issue persists, please contact your Dealer to inspect and repair as needed.

## O. TV ANTENNA

### 1. Poor TV Reception

- Check that the Antenna Power is ON.

Note that it is located in the ceiling behind the bedroom TV.

- Check the connections at both the TV and wall plate.

If the issue persists, please contact your Dealer to inspect and repair as needed.

## P. WASTE TANK

### 1. Waste Tank (Black) Will Not Properly Drain

- Check for debris or buildup within the tank and clean as needed. To prevent buildup:
  - Use RV biodegradable toilet paper
  - Use plenty of water when flushing
- Check termination valve for possible obstructions.

If the issue persists, please contact your Dealer to inspect and repair as needed.

## Q. WATER HEATER—TANKLESS

Follow any other troubleshooting and maintenance suggestions provided within the manufacturer's manual.

## R. WATER PUMP

### 1. Pump Inoperable

- Ensure there is sufficient power.
- Check pump switch and connection at the monitor panel.

- Inspect the fuse in power center to ensure it isn't blown.
- Verify the water is not frozen.

If the issue persists, please contact your Dealer to inspect and repair as needed.

### 2. Pump Will Not Prime

- Ensure there is sufficient water in the tank. This can be checked at the monitor panel.
- Verify there isn't trapped air in the hot water heater.
- Verify the water is not frozen.

If issue persists, please contact your Dealer to inspect and repair as needed.

### 3. Pump Runs Even When Water Is Off

- Ensure all water sources are turned off.
- Turn off the pump using the switch in the convenient center or the monitor panel.
- Check for water collections near or around plumbing appliances and fittings.
- Inspect toilet for leaking valves.

If issue persists, please contact your Dealer to inspect and repair as needed.

## S. WATER SYSTEM

### Wet Areas Near Water Connections, Pump Runs While the Faucets are Closed, and No Other Fresh Water Fixtures are Being Used

- Check for water leaks.
- Close all valves and low points to tanks and drains.
- Ensure all water fixtures are properly closed.
- Verify that all fixtures and connections are tight.

**DO NOT over tighten fittings. This may damage seals and cause additional leakage.**



## SEC.30 GLOSSARY

### **3-SEASON DOOR**

This refers to the patio door on a toy hauler.

### **7-WAY**

A generic term for a hitch plug or connector. This plug connects the towing vehicle to the RV and supplies power to the turn signals, clearance lights, brakes, camera(s), and breakaway switch while the tow vehicle is in operation.

### **AC ELECTRICITY**

Alternating current is an electric current which periodically reverses direction and changes its magnitude continuously with time in contrast to direct current which flows only in one direction. For purposes of this manual, it refers to 120-volt.

### **AC**

(Abbreviated 120 VAC).

### **AMP**

Short for ampere, the electrical current unit of measure. RV sites with electric hookup will specify the maximum amps supported, which generally come in units of 20, 30, or 50 amps. The RV power connector must match the various plugs of the site amp rating. Keep in mind that if using a reducer, your usage of items will be limited. If an outlet is not labeled, please have it tested prior to plugging into it.

### **AUXILIARY BATTERY**

An auxiliary battery allows you to power 12-volt DC devices anywhere, any time. This is a Customer/Dealer purchased, installed item.

### **AWNING**

A canvas or other artificial material which extends from the RV body to provide shade. Awnings are generally placed on the entrance side of the RV. Not meant to be shelter or protection from storms.

### **BATTERY CONTROLLER**

Maintains the life of the battery by preventing it from being overdrawn or overcharged.

### **BLACK WATER**

Is human waste collected from the toilet. The black water can be emptied through a black water hose at a dedicated RV sewage dump.

### **BLUE BOY**

Also known as a Honey Wagon, is a portable waste tank that allows you to dump your RV's sewage or gray water without taking your whole RV to the dumpsite.

### **BOONDOCKING**

Is camping without hookups to electricity, water or sewage. Keep in mind that without alternate charge this is taxing on your auxiliary battery.

### **BREAKAWAY SWITCH**

Is designed to bring a trailer to a safe stop by activating the electric brakes on the trailer, should the trailer be disconnected from the tow vehicle while driving. Do not pull this to test your brakes. You must have operational electric brakes on the unit, the 12-volt battery must be charged & the switch cable must be attached to the vehicle.

### **BRAKE CONTROLLER**

Is an electronic device that activates and, as the word suggests, controls the electric brakes of a trailer. This device can be integrated or added to the tow vehicle. **NOT SUPPLIED WITH RV.**

### **BRITISH THERMAL UNIT (BTU)**

Measurement of the heat content of fuels or energy sources. It is the quantity of heat required to raise the temperature of one pound of liquid water by 1° F (-17.2° C) at the temperature that water has its greatest density (approx. 39° F or 3.9° C).

### **CAMBER (WHEEL ALIGNMENT)**

Is one of the angles made by the wheels of a vehicle; specifically, it is the angle between the vertical axis of a wheel and the vertical axis of the vehicle when viewed from the front or rear.

### **CAMPING**

An outdoor activity involving overnight stays away from home, either without shelter or using basic shelter such as a tent or a recreational vehicle.

**CARBON MONOXIDE**

A colorless, odorless toxic flammable gas formed by incomplete combustion of carbon.

**CARGO WEIGHT**

The actual weight of all items added to the Curb Weight of the vehicle or trailer. Exceeding this weight could void certain warranties or cause damage to the RV.

**CARGO CARRYING CAPACITY (CCC)**

The Maximum permissible weight of personal belongings that can be added up. It is equal or less than Gross Vehicle Weight Rating minus Unloaded Vehicle Weight, full freshwater weight, and full LP (liquid propane) gas weight, and holding tank weights.

**CITY WATER**

This is a faucet at your campsite that allows you to connect your RV directly to a city water supply. No pump needed.

**CONDENSATION**

Is the water droplets that form on your RV walls, windows and make things feel wet. This can cause mold and mildew to form in your RV on walls, under the mattress, and more.

**CONVERTER**

An RV converter is responsible for converting standard 120-volt AC power into 12-volt DC power. The unit must be plugged in for this device to work.

**CURB WEIGHT**

The actual weight of a vehicle or trailer, including all standard equipment, full fuel tanks, full freshwater tanks, full propane bottles, and all other equipment fluids, but before taking on any persons or personal cargo.

**CURBSIDE**

This refers to the side of the camper that faces the curb when parked. Also referred to as the door side, DS, or passenger side.

**DC ELECTRICITY**

Direct current is one-directional flow of electric charge. The auxiliary battery and converter both provide DC electricity. (Abbreviated 12 VDC).

**DEALER**

Means any person who sells or solicits or advertises the sale of new recreational vehicles.

**DINETTE**

Booth-like dining area. Table usually drops or is removable to convert into a bed at night.

**DIRECT DUMP A/C**

Air conditioning supplied directly from the vent on the A/C unit.

**DISTRIBUTION PANEL**

Refers to the power center that houses the breakers and distributes power to the RV.

**DRY CAMPING**

Camping when there is no city water hookup or shore power (i.e., using only the water and power available in the camper and not from any other source).

**DRY WEIGHT**

Is the weight of an RV as built at the factory. (UVW= Unloaded Vehicle Weight).

**DSI (DIRECT SPARK IGNITION)**

This term refers to the method of igniting the main burner on a propane fired appliance. The burner is lit with an electric spark and the flame is monitored by an electronic circuit board. This ignition system is used in refrigerators, furnaces, and water heaters. There is now a version of stove tops that light the burners with a DSI ignition.

**DUAL ELECTRICAL SYSTEM**

RV equipped with lights, appliances which operate on 12-volt battery power when self-contained, and with a converter, on 120VAC when in campgrounds or with an on-board generator.

**DUALLY**

Truck having two wheels on each side for a total of four wheels. This allow for more load capability.

## SEC.30 GLOSSARY

### **DUCTED A/C**

Air conditioning supplied through a ducting system in the ceiling. This supplies cooling air at various vents located throughout the RV.

### **DUCTED HEAT**

Warm air from the furnace supplied to various locations in the RV through a ducting system located in the floor. (Similar to house heating systems).

### **DUMP STATION**

Site where you drain your gray water (waste) and your black water (sewage) tanks. In most states, it is illegal to drain your tanks anywhere except dump stations.

### **DUMP VALVE**

Another name for the T-handle valve used to release and drain the black tank (sewage) and gray tank (waste).

### **EGRESS WINDOW**

Is essentially an emergency exit window in your RV that allows for the safe evacuation of occupants. (These windows are labeled).

### **E-TRACK**

A recessed track that is designed to hold tie-down rings to assist in strapping down cargo.

### **FIFTH WHEEL (FW)**

A trailer and hitch configuration connected to the tow truck directly above the rear axle by way of a special fifth wheel hitch. This causes several feet of the connected trailer to hang over the tow truck, placing about 15 to 25% of the trailer's weight on the rear axle of the truck. Commercial trucks and trailers use this hitch configuration. Also commonly spelled as 5th wheel.

### **FRESH WATER**

The freshwater system provides potable water to the kitchen sink, shower, bathroom lavatory, toilet, water heater and outside shower.

### **FRESH WATER TANK**

Tank for holding freshwater for drinking, cooking, and bathing while not connected to a city water supply.

### **FULL HOOKUP SITE**

A campsite that has city water, shore power and sewer hook-ups or connections available.

### **FULL-TIMERS or FULL-TIMING**

The term used for people who live in their RV full-time, or at least the vast majority of their time.

### **GALLEY**

The kitchen in an RV.

### **GARAGE**

Refers to the back portion of the toyhauler where power sports tend to be stored.

### **GENERATOR**

An engine powered device fueled by gasoline or diesel fuel, and sometimes propane, for generating 120-volt AC power.

### **GENSET**

Abbreviation for built in generator.

### **GOOSENECK**

A trailer and hitch configuration connected to the tow truck directly above the rear axle by way of a standard ball hitch in the truck bed and a vertical, slender arm on front of the trailer.

### **GRAY WATER**

Term associated with the wastewater holding tank. Water from the sink drains, shower and washer/dryer go into this tank.

### **GROSS AXLE WEIGHT RATING (GAWR)**

The MAXIMUM ALLOWABLE WEIGHT each axle assembly is designed to carry, as measured at the tires, therefore including the weight of the axle assembly itself. GAWR is established by considering the rating of each of its components (tires, wheels, springs, axle), and rating the axle on its weakest link. The GAWR assumes that the LOAD IS EQUAL ON EACH SIDE.

**GROSS CARRYING CAPACITY (GCC)**

Means the maximum carrying capacity of your camper. The GCC is equal to the GVWR minus UVW. The GCC will be reduced by the weight of fresh water or other tanks, propane, occupants, personal items or Dealer installed accessories. (Also referred to Cargo Carrying Capacity).

**GROSS COMBINED WEIGHT RATING (GCWR)**

The MAXIMUM ALLOWABLE COMBINED WEIGHT of the tow vehicle and attached towed vehicle. GCWR assumes that both vehicles have functioning brakes, with exceptions in some cases for very light towed vehicles, normally less than 1,500 pounds (680.4kg). (Check your tow vehicle's towing guide.)

**GROSS TRAILER WEIGHT RATING (GTWR)**

The MAXIMUM TOWED VEHICLE WEIGHT. Each component (receiver, drawbar, ball) of a ball-type hitch has its own rating. Some ball-type hitches have separate ratings when used with a weight distributing system.

**GROSS VEHICLE WEIGHT RATING (GVWR)**

The MAXIMUM ALLOWABLE WEIGHT of the fully loaded vehicle, including liquids, passengers, cargo, and the tongue weight of any towed vehicle.

**HEAT EXCHANGER**

A device that transfers heat from one source to another. For example, there is a heat exchanger in your furnace, the propane flame and combustion products are contained inside the heat exchanger that is sealed from the inside area. Inside air is blown over the surface of the exchanger, where it is warmed and blown through the ducting system for room heating. The combustion gases are vented to the outside air.

**HEAT STRIP**

A heat strip is an electric heating element located in the air conditioning system with the warm air distributed by the air conditioner fan and ducting system. They are typically 1500-watt elements (about the same wattage as an electric hair dryer) and have limited function.

**HEPVO VALVE**

Is a unique self-sealing waste valve that prevents the escape of foul sewer air from waste discharge systems, and actively maintains the pressure equilibrium in soil and waste installations.

**HIGH PROFILE**

Is any vehicle that has a large, exposed surface area that cross winds can affect.

**HITCH**

The fastening unit that joins an RV to the tow vehicle.

**HITCH WEIGHT**

The amount of the camper's weight that rests on the tow vehicle. It should be approximately 12% - 15% with conventional travel trailers; approximately 18% -21% for fifth wheels.

**HOLDING TANKS**

These are containers that store the fresh and wastewater in the RV. There are three types, freshwater, wastewater, and black water holding tanks.

**HONEY WAGON**

A truck or trailer that will travel to campsites, release the waste from your black and gray tanks and carry it off.

**HOOKUPS**

The ability of connecting to a campground's facilities. The major types of hookups are electrical, water and sewer. If all three of these hookups are available, it is termed full hookup. Hookups may also include telephone and cable TV in some campgrounds.

**HOUSE BATTERY**

One or more batteries in an RV for operating the 12-volt lights, appliances, and systems. House batteries can be 12-volt units tied in parallel or pairs of 6-volt batteries tied in series (to double the voltage). The term house battery is of more significance in motor homes because they contain one or more other batteries for the operation of the engine, referred to as the chassis or starting batteries.



### **INVERTER**

An inverter is a device that changes 12-volt battery power to 120-volt AC power. It is used when “boon docking” (camping without hookups) to power certain 120 VAC only devices like a microwave oven. The amount of available power depends on the storage capacity of the batteries and the wattage rating of the inverter.

### **ISLAND QUEEN or ISLAND KING**

A king or queen-sized bed with walking space on both sides.

### **JACKKNIFE**

The 90° angle obtained from turning/backing fifth wheel or travel trailer with tow vehicle. Jackknifing a short bed truck towing a fifth wheel without the use of a slider hitch or extended fifth wheel pin box can result in damage to the truck cab or breaking out the back window of the truck cab from the truck and fifth wheel “colliding.”

### **KINGPIN**

The pin by which a fifth wheel trailer attaches to the truck. It slides into the fifth wheel hitch and locks in place.

### **KINGPIN WEIGHT**

The actual weight pressing down on the fifth wheel hitch by the trailer. The recommended amount of Kingpin Weight is 15%-25% of the GTW, also called Pin Weight.

### **LAMINATE**

A sandwich of structural frame members, wall paneling, insulation and exterior covering, adhesive-bonded under pressure and/or heat to form the RV's walls, floor and/or roof.

### **LANDING GEARS**

See Leveling Jack.

### **LEVELING**

Positioning the RV in camp so it will be level, using ramps (also called levelers) placed under the wheels, built-in scissors jacks, or power leveling jacks.

### **LEVELING JACK**

A jack lowered from the underside of trailers and motor homes for the purpose of leveling the vehicle. A leveling jack is designed to bear a significant portion of the RV's weight.

### **LP GAS**

Liquified Petroleum Gas, commonly written as “LP Gas.” Two examples of LP Gas are propane and butane. LP Gas is heavier than air in gas form and about half the weight of water in liquid form. LP gas is used to fuel appliances in the RV, such as the stove, oven, water heater and refrigerator. Propane tanks are usually rated as pounds or gallons.

### **LOW POINT**

The lowest point in the plumbing. Drains are placed here so that water will drain out of the lower end of the camper when flushing or winterizing the water system. These drains must be closed when you fill the water tank.

### **MONITOR PANEL/CONVENIENCE CENTER**

The panel in which the tank monitor is located and the panel that has the common RV function switches.

### **MOTORHOME (MH)**

A motor vehicle built on a truck or bus chassis and designed to serve as self-contained living quarters for recreational travel.

### **NET CARRYING CAPACITY (NCC)**

The MAXIMUM WEIGHT of all personal belongings, food, fresh water, propane, tools, Dealer installed accessories, etc., that can be carried by the RV.

### **NON-POTABLE WATER**

Water NOT suitable for human consumption.

### **OEM**

This refers to the original equipment manufacturer of the individual appliances or components.

**PATIO MAT**

Carpet or woven mat for use on ground outside of RV. Used whether or not a concrete patio pad is available where camping.

**PAYLOAD CAPACITY**

The maximum allowable weight that can be placed in or on a vehicle, including cargo, passengers, fluids and fifth-wheel or conventional hitch loads.

**PILOT**

A pilot is a small standby flame that is used to light the main burner of a propane fired appliance when the thermostat calls for heat. Pilots can be used in furnaces, water heaters, refrigerators, ovens, and stove tops.

**PIN BOX**

Is the hitch of the fifth wheel that connects the RV to the tow vehicle.

**PORPOISING**

A term used to define the up and down motion in an RV while traveling. Also commonly referred to as “chucking.”

**POWER SOURCE**

Also referred to as shore power, this refers to the receptacle outlet you are using to plug in your shoreline power cord. This can be a campsite power box or electrical box, a residential receptacle outlet specifically wired for your camper or a generator (Customer Supplied).

**PRIMITIVE SITE**

A campsite that may have city water, shore power or sewer hook-ups but not all of them; primitive sites may have no hook-ups or connections at all.

**PROPANE**

LPG, or liquified petroleum gas, used in RV's for heating, cooking and refrigeration. Also called bottle gas, for manner in which it is sold and stored. This is the proper term in the RV industry when referring to “LP Gas.”

**PULL-THROUGH SITES**

Campsites you can drive through and park (without having to back up into the site).

**REFER**

Slang for “Refrigerator.”

**RIG**

What many RV'ers call their units.

**ROADSIDE**

The side of the trailer that faces the road when it is parked. Also called the streetside, off door side or ODS.

**ROOF AIR CONDITIONING**

Air conditioning unit mounted on roof of RV, to cool the RV when it is parked. When moving, most RV's are cooled by separate air conditioning units which are components of the engine, or they may be cooled by a roof top if a proper size generator is installed.

**RV**

Short for Recreation Vehicle, a generic term for all pleasure vehicles which contain living accommodations. Multiple units are RV's and persons using them are RV'ers.

**RVDA**

Abbreviation for Recreational Vehicle Dealer's Association.

**RVIA**

Abbreviation for Recreational Vehicle Industry Association.

**SELF CONTAINED**

RV which needs no external electrical, drain or water hookup. Thus, it can park overnight anywhere. Of course, self-contained units can also hook up to facilities when at campgrounds.

**SANITIZATION**

Refers to the camper's freshwater system that has been sanitized with chlorine bleach before use or after storage.

### **SHORE POWER**

120-volt AC power that is supplied by an external source such as a campground or house set-up.

### **SHORELINE POWER CORD**

This is the electrical power cord that runs from the camper to the campsite shore power outlet.

### **SLEEPING CAPACITY WEIGHT RATING (SCWR)**

The manufacturer's designated number of sleeping positions multiplied by 154 pounds (70 kilograms).

### **SLIDE-OUT**

A compartment added to an RV to increase interior space. It slides into the body during travel and slides out when parked.

### **SNOWBIRD**

Term for someone in a northern climate that heads "south" in winter months.

### **STINKY SLINKY**

Slang for the sewer hose, constructed from a spiral wire covered with vinyl. One end attaches to the RV piping and the other into the local sewer dump facilities.

### **STREETSIDE**

The side of the trailer that faces the street when parked. Also called the roadside, off door side or ODS.

### **SURGE PROTECTOR**

Device (Customer Supplied) that is installed at the power supply location designed to prevent "surges" or "spikes" in electrical current that may damage the RV's electrical/electronic components.

### **SWAY**

Fishtailing action of the trailer caused by external forces that set the trailer's mass into a lateral (side-to-side) motion. The trailer's wheels serve as the axis or pivot point. Also known as "yaw."

### **THERMOCOUPLE**

A thermocouple is a device that monitors the

pilot flame of a pilot model propane appliance. If the pilot flame is extinguished the thermocouple causes the gas valve to shut off the flow of gas to both the pilot flame and the main burner.

### **TIE-DOWN RING**

Anchor that can be inserted in the E-Track to assist in securing cargo.

### **TIP OUT**

The term used for an area or room in an RV that tips out for additional living space. The Tip-Out was generally used in older RV's. Newer RV's mainly use a slide-out.

### **TIRE RATINGS**

The MAXIMUM LOAD that a tire may carry is engraved on the sidewall, along with a corresponding COLD inflation pressure. A reduction in inflation pressure requires a reduction in load rating. Tire manufacturers publish charts that establish the load capacity at various inflation pressures.

### **TOE (WHEEL ALIGNMENT)**

Toe is the measure of whether the front of the wheels (looking down from the top) are closer (toe-in) or farther (toe-out) than the back of the wheels.

### **TONGUE WEIGHT, TONGUE LOAD, VERTICAL LOAD (TWR/TLR/VLR)**

Tongue Weight, Tongue Load, Vertical Load Rating Different terms for the MAXIMUM VERTICAL LOAD that can be carried by the hitch UNLOADED.

### **TRAILER BRAKES**

Brakes that are built into the trailer axle systems and are activated either by electric impulse or by a surge mechanism. The overwhelming majority of RV's utilize electric trailer brakes that are actuated when the tow vehicle's brakes are operated, or when a brake controller is manually activated. Surge brakes utilize a mechanism that is positioned at the coupler, that detects when the tow vehicle is slowing or stopping and activates the trailer brakes via a hydraulic system (typically used on boats).

### TRAVEL TRAILER (TT)

Also referred to as “conventional trailers,” these types of rigs have an A-frame and coupler and are attached to a ball mount on the tow vehicle. Travel trailers are available with one, two or three axles. Depending upon tow ratings, conventional trailers can be towed by trucks, cars or sport-utility vehicles.

### UNDERBELLY

The RV’s under-floor surface, which is protected by a weatherproofed material.

### UTQGL (UNIFORM TIRE QUALITY GRADE LABELING)

A program that is directed by the government to provide consumers with information about three characteristics of the tire: tread wear, traction, and temperature. Following government prescribed test procedures, tire manufacturers perform their own evaluations for these characteristics. Each manufacturer then labels the tire, according to grade.

### UV DEGRADATION

A breaking down of material due to the sun’s harsh ultraviolet rays.

### UNLOADED VEHICLE WEIGHT (UVW)

The WEIGHT of a vehicle as built at the factor with full fuel, engine (generator) oil and coolants. It does not include cargo, fresh water, propane, occupants, or Dealer installed accessories.

### WASTEWATER TANKS

The gray water tank holds the wastewater from the sinks and showers. The black water tank holds the waste from the toilet.

### WATER PRESSURE REGULATOR

Device (Customer Supplied) installed on the water hose attached to city water to limit the water pressure entering the RV. Most regulators limit water pressure to 40 psi (275.8 kPa).

### WEIGHT AND LOAD

These terms are generally used interchangeably. For the purposes of understanding RV applications:

- Vehicles have WEIGHT, which impart LOADS to tires, axles and hitches.
- Scale measurements taken when weighing, are LOADS carried by the tires. The measured LOADS are used to calculate Gross Combination Weight (GCW) Gross Vehicle Weight (GVW), Gross Axle Weight (GAW), and Hitch Loads.

### WET WEIGHT

The weight of the vehicle with the fuel, freshwater and propane tanks full.

### Note these important weights:

|             |                                      |
|-------------|--------------------------------------|
| Propane     | 4.25 lbs. per gallon (0.51 kg/liter) |
| Water       | 8.3 lbs. per gallon (0.995 kg/liter) |
| Gasoline    | 6.3 lbs. per gallon (0.755 kg/liter) |
| Diesel fuel | 6.6 lbs. per gallon (0.79 kg/liter)  |

### WHEEL CHOCKS

Any solid material such as rubber, dense plastic, wood, etc. that can be placed in front or behind the tire to prevent the RV from rolling when in a parked position.

### WIDE BODY

An RV having an external body width greater than 96 inches (2.44 m). The most common wide-body widths are 100” (2.54 m) and 101” (2.654 m).

### WINTERIZED

Refers to a camper that has been prepared for storage. The water systems have been drained and RV antifreeze has been added to protect the water lines and drains. The low point drains should be in the open position.

### YAW

Fishtailing action of the trailer caused by external forces that set the trailer’s mass into a lateral side-to-side) motion. The trailer’s wheels serve as the axis or pivot point. Also known as “sway.”











BrinkleyRV.com

5.25.23